

Climate Protection and Energy Supply in Germany 1990 – 2020

A study by the Deutsche Physikalische Gesellschaft
(German Physical Society)

Bad Honnef, September 2005

Foreword

This study of measures to curb global warming linked with the energy supply in Germany is presented by the Deutsche Physikalische Gesellschaft (DPG). The DPG and its working group on energy (Arbeitskreis Energie) regularly inform the scientific and general public about issues related to energy as a matter of public concern [1]. Ever since the early 1980s the DPG has addressed itself with particular interest to the phenomenon known today as the “greenhouse effect”, bringing it to public attention very early on [2]. Now, at a time when energy policies are about to be reshaped by important new decisions, we would like to contribute to the public discussion an overall assessment of emission-reduction options in Germany. (Footnotes on page 3).

Therefore, the study has no sponsor. It differs in this respect from expert opinions on the climate change issue that have been commissioned by the ministries of the environment and of economics or by industrial groups.

The team of authors have been working on the study on an honorary basis since October 2004. They have based their findings on existing investigation material and on lectures by experts who have explained their special areas of expertise to the working group on energy. The study does not, of course, have access to the resources of major institutes that are normally employed in drawing up expert opinions, such as programmes for simulating complex processes, or extensive databases. And naturally, it focuses more heavily on the physical and technical aspects of the issue than on economic or political aspects.

The climate changes caused by man may be the biggest environmental problem facing us this century, and they are a global problem. There are some encouraging signs that this fact has been acknowledged and that the international community of nations is seriously seeking solutions. Germany’s scientific, technical and economic status places it in a position to play a leading role in this quest. Much has been done already, but there is a great deal more still to be done. The present study is intended as a guide in accomplishing this task.

The German version of this study was presented to the public during a press conference in the Magnus-Haus in Berlin on November 8th, 2005, and is available since then (<http://www.dpg-physik.de>). The results and conclusions drawn in this study are still valid today, about one year later. This English translation should make this work available to a much wider public, in particular in Europe.

Prof. Dr. Walter Blum

Head of the working group on energy at the Deutsche Physikalische Gesellschaft

Prof. Dr. Eberhard Umbach

President of the Deutsche Physikalische Gesellschaft

Prof. Dr. Knut Urban

Vice-President of the Deutsche Physikalische Gesellschaft

Summary: Ten insights concerning climate change policy

1. The climate situation and the challenge it entails

Experts are unanimous in their opinion that the rise in the temperature of the atmosphere caused by human activities must be limited to not more than two degrees Celsius if we are to avoid a climate disaster. The first step that must be taken is to stabilise global greenhouse gas emissions, then ultimately to bring them down to half of their 1990 level by the middle of the 21st century. To achieve this goal, the industrialised countries, which alone account for half of all emissions, must reduce their emissions far more drastically than they have done before now.

2. The goal of Germany's climate change policy

Germany and Europe will have to make a decisive contribution to this mammoth task, not only by reducing their own greenhouse gas emissions, but also by identifying ways of tackling the climate problem. Since only 3-4% of global greenhouse gas emissions are produced by Germany, it is clear that reducing German emissions will hardly improve the global climate. The intent and purpose of German climate change policy can only be to make contributions that will encourage the other players to join forces in undertaking the right measures. The ultimate justification for this policy can thus be sought in Germany's diplomatic, commercial, scientific and technological status; its other objective is to identify and capitalise on new opportunities for export. Germany can only convincingly assume its role in Europe and in international climate change policies if the arguments that it puts forward and the performance it can be seen to deliver are not only rational, but are perceived in the international arena as being worthy of imitation.

3. The study: time horizon, strategy

The present study examines the situation in Germany over two 15-year periods stretching from 1990 to 2020. It begins by looking back at the past 15 years: What has been achieved since 1990, the reference year for calculating the targeted reductions of greenhouse gases? Then the study looks ahead at the next 15 years: What would be the result of continuing the present trend until 2020, the year by which the German federal government hopes to achieve a 40% reduction of greenhouse gas emissions, and what can the efforts already planned for this period (greater use of renewable energy sources, modernisation of fossil-fired power plants, phase-out of nuclear power plants) be expected to yield over and above this trend?

4. Result of 15 years of climate change policy – the trend

Discounting the immediate effects of German reunification, the observed CO₂ emissions for the past 15 years display a uniform reduction of only 0.6% per year (a rate similar to that in the United Kingdom, for example). Germany fell far short of its goal of reducing CO₂ emissions by 25% by the year 2005, even though this goal had occupied a central role in German environmental policy for many years. In fact, it could only have been achieved with two and a half times the reduction rate per year. This result is disappointing given that both industry and the government have made tremendous efforts to reduce greenhouse gas emissions over the past 15 years. A continuation of this trend would result in annual greenhouse gas emissions of 871 million metric tons of CO₂ equivalent in the year 2020, which would represent a 30% reduction rather than the hoped-for 40%, compared with the baseline year 1990, (1,254 million metric tons CO₂ equivalent).

5. Potential reduction over and above the present trend

The study goes on to examine which of the planned measures would be able to change this trend by the year 2020. After discussing the potential for cutting consumption, which is in theory quite high but cannot be expected to yield any further savings beyond the present trend, the study examines the eight most important methods of producing consumer energy: high-efficiency fossil-fired power plants, the renewables – photovoltaics, wind energy, biomass –, and then alternative fuels, nuclear power, fossil-fired power plants with CO₂ sequestration, and solar thermal power plants in southern latitudes. Of all these options, the latter two cannot be expected to alter the trend by 2020, as they will be unable to produce a sufficiently large quantity of electricity by that time. For the other methods, the changes achieved over and above the present trend can be estimated as follows (in millions of metric tons of CO₂ per year): (a) Power from renewable energies (mainly wind energy): reduction by 8 to 15, (b) modernising fossil-fired power plants and doubling the proportion of electricity from gas to 32%: reduction by 23, (c) introducing alternative fuels for road transport: reduction by 20, (d) switching off nuclear power plants and replacing them by state-of-the-art fossil fuel power plants with a 40% proportion of gas: increase by 112.

6. CO₂ emissions in 2020 with and without nuclear power

The overall effect of these measures in the year 2020 will be an annual increase of emissions by 54 to 61 million metric tons of CO₂ over and above the trend if nuclear energy is phased out, or a reduction of emissions by 51 to 58 million metric tons of CO₂ if the nuclear power plants are kept in operation. The value of 871 million metric tons of CO₂ equivalent per year, obtained by extrapolating the observations of the last 15 years through until 2020 is thus increased or decreased by these amounts. Even in the most favourable case (nuclear power plants are kept in operation, the expansion of renewable energies is pursued to maximum effect), Germany will still be more than 60 million metric tons of CO₂ equivalent short of its target of “minus 40% by 2020”. If the nuclear power plants are closed down, the result of 30 years’ “climate protection” would add up to no more than a 26% reduction compared to the baseline level in 1990.

7. Future energy policies need a broad base

In order to achieve a better performance in terms of reducing emissions, German energy policy must spread its options as broadly as possible. It is important to have a choice of various options because we cannot know in advance what the ultimate economic and technical outcome of any specific option will be, so we need alternatives. The study first underlines the importance of processes for CO₂ sequestration at fossil-fired power plants. This option is already an integral element of Germany's energy policy. After this, the study focuses particularly on two further options that are not yet commonly recognised as instruments of German energy policy: the continued use of nuclear power plants and the construction of solar thermal power plants in southern latitudes.

8. Plea for the continued use of nuclear power

As shown above, the measure that will have by far the greatest impact on the present trend is the planned closure of nuclear power plants. Even the sum of all other individual measures is unable to compensate for this (by a factor of two). Whilst originally we had hoped to have sufficient leeway to compensate for the loss of CO₂-free electricity derived from nuclear power, today we are forced to realise that such an equation will not balance out. Instead, what we must do is to prolong the phase-out plans over a realistic period of time commensurate with the reduction of CO₂ emissions. This applies regardless whether nuclear power is revived or completely phased out. To shut down these power plants according to plan would make nonsense of all the efforts made so far to reduce CO₂ emissions.

9. Plea for solar thermal power plants in southern latitudes

Seen from a physical and technical point of view, there can be no doubt that solar thermal power plants in southern latitudes represent one of the best options for supplying the requisite large quantities of CO₂-free electricity. The relevant research and development activities have been in progress for about 25 years, and have reached a stage where it is time to energetically pursue their commercialisation. The Deutsche Physikalische Gesellschaft appeals to all the parties involved – industry, energy providers and the appropriate government bodies – to do everything in their power to promote the launch of the outlined programme to create a market for solar thermal power plants in the Earth's equatorial sun belt.

10. We can justifiably hope for new inventions

Providing incentives that will encourage successful research and creating the appropriate research infrastructure must also be seen as a valuable investment towards finding solutions to global warming.

Table of Contents

Foreword	I
Summary: Ten insights concerning climate change policy	II
Introduction	1
1 Evolution 1990 - 2020	4
1. Evolution from 1990 until now	
2. Future development through to 2020	
2 Saving energy at the point of consumption	13
1. Existing energy-saving potential	
2. Actual rates of decrease in buildings	
3. Energy prices	
4. Research and development	
3 High-efficiency fossil-fired power plants	21
1. The present role of fossil-fired power plants in Germany's electricity supply	
2. Outlook for power generation from fossil fuels	
3. Potential efficiency improvements to fossil-fired power plants	
4. Estimate of the reduction in CO ₂ emissions achievable in the electricity sector by 2020	
4 Photovoltaics	31
1. Introduction	
2. Costs and cost reduction potential	
3. Necessity for research and development	
4. The explosive growth of photovoltaics in Germany	
5. Assessment of the contribution made by photovoltaics to climate protection up to 2020	
5 Wind energy	35
1. Development of wind energy in Germany	
2. Development of wind energy, mainly offshore	
3. Summary of the share of wind energy in the Germany power-generation system	
Annex: Critical assessment of development plans up to 2020 as seen by the dena grid study	
6 Biomass	46
1. What is biomass	
2. Current energy use of biomass	
3. The diverse technical uses of biomass	
4. The potential of biomass usage around the globe and in Germany	
5. Assessment of the environmental and long-term economic rôle of biomass	
7 Energy for road transport – alternative fuels	56
1. Introduction	
2. Options for alternative fuels and their assessment	
3. Potential savings for road transport up to 2010 and 2020	

8 Nuclear power	65
1. Overview of nuclear power usage in Germany	
2. Contribution of nuclear energy to climate protection over the medium term (up to 2020)	
3. Conclusions	
9 Fossil-fired power plants with CO₂ sequestration	71
1. The problem	
2. The process of separating CO ₂	
3. Transport and storage	
4. First pilot plants for CO ₂ sequestration	
5. Evaluation of CO ₂ sequestration	
10 Solar thermal power plants in southern latitudes	80
1. State of the art	
2. Potential for medium-term technical progress	
3. Costs and potential savings	
4. Solar power from North Africa for Europe/Germany	
5. Conclusions and plea for action	
11 Final appraisal and plea for action	88
1. Summary of conclusions so far	
2. Assessment of possible reductions over and above the trend	
3. Overall assessment	
4. Instruments to further reduce emissions	
5. Plea for the continued use of nuclear power	
6. Plea for solar thermal power plants in southern latitudes	
12 Concluding remarks	101
Authors and Publishing notes	102

Introduction

Man's contribution to global warming is no longer merely a scientific hypothesis but an established fact. A topic of public controversy since the early 1980s, the climate change has meanwhile been well enough understood to establish a satisfactory correlation between the theory and the measured data, and to explain these data correctly. The changes caused by man are beginning to show. It is a proven fact that the concentration of greenhouse gases (CO₂, CH₄, N₂O, HFC, CF₄, C₂F₆ etc.) in the atmosphere has rapidly increased due to man's industrial activities, and that these gases have heated the atmosphere and will continue to do so for many more decades due to their long average atmospheric lifetime [1].

The United Nations Framework Convention on Climate Change, which entered into force in 1994, and the Kyoto Protocol, which was ratified in 1997 and took effect in 2005, are international treaties for a coordinated global approach targeted at first stabilising annual emissions of greenhouse gases then cutting them to half of their 1990 levels by the middle of the 21st century. This is probably the only way in which the global warming [2] anticipated for the end of this century can be restricted to two degrees Celsius – the generally accepted upper limit at which the flora and fauna will still be able to adapt to the climate change through evolution. Attaining or exceeding this level of global warming will cause considerable damage to humanity [3], and this damage must be curbed as far as possible by adopting a responsible climate policy [4].

Efforts to halve the annual global emission of greenhouse gases by the middle of this century must make allowances for the fact that the world's nations are at different stages of technological and economic development. Those at the beginning or in the middle of their development will initially produce increased emissions, even if they take the climate problem fully into consideration. This is a natural consequence of the basic right to equal treatment for all peoples and of the expected population explosion. The German parliament's Enquete-Kommission has estimated [6] that if the world as a whole is to halve its emissions, the industrialised countries – which alone account for half of all emissions worldwide – will actually have to cut their emissions by 80% before the middle of the century. Although global climate policies have not yet achieved universal recognition of such stringent global commitments, it is important not to lose sight of this long-term goal. The immediate targets of the industrialised countries are not quite so radical at present, but nonetheless extremely demanding.

Germany and Europe must assume a fair share of this monumental task, not only by reducing their own greenhouse gas emissions and pursuing an active international climate policy, but also by identifying ways of addressing the challenges posed by the climate problem. This means that in Germany, too, techniques for saving energy and improving efficiency must be promoted. Innovative methods of energy conversion must be developed, with the focus until 2020 being placed on renewable energy sources and CO₂ sequestration. The time likely to elapse before these methods become effective in reducing CO₂ emissions is one of the main topics of the present investigation. Evidently, the timeline has tended to be greatly underestimated.

CO₂ – the core problem of greenhouse gas emissions

We need to differentiate between the various greenhouse gases, as they not only have a very different impact on global warming, but are also discharged in dissimilar quantities. Moreover, they originate from a wide variety of sources. The list in Table 0-1 below makes allowances for the different impact of these gases (Global Warming Potentials [7]), factoring in the relevant figures for Germany in 1990 as published in the National Climate Protection Programme document [8]. The year 1990 is the baseline from which the reductions are going to be calculated.

Greenhouse gas	Source	Quantities	Share
Carbon dioxide CO ₂	Almost entirely from the combustion of fossil fuels	1,014.500 Mt	83.9%
Methane CH ₄	From animal husbandry (34%), waste disposal sites (34%), coal extraction (22%), gas production and transport (6%), other sources (4%)	5.571 Mt	9.7%
Nitrous oxide N ₂ O	From industrial processes (40%), agriculture (40%), traffic and other energy conversion methods (20%)	0.225 Mt	5.7%
All other Kyoto gases			about 0.7%

Table 0-1: Source of German emissions and quantities in megatons (Mt) in 1990, and their share in global warming

It is extremely difficult to reduce emissions of these substances to only fractions of their initial values on a permanent basis, as this necessitates interfering with well-established running processes. Experience has shown [8] that carbon dioxide is, comparatively speaking, the most difficult emission to reduce. This is hardly surprising, given that the bulk of our energy supply and most of our traffic relies on the combustion of fossil fuels. Climate problems thus affect energy policies.

The 1990 baseline from which the required reductions are calculated – on an international as well as a domestic scale –, and in which Germany released about a billion metric tons of carbon dioxide into the atmosphere, is now 15 years behind us. Since then, industry and the government have undertaken tremendous efforts to reduce emissions of greenhouse gases. The government has set national goals for emission reductions and has accepted emission limitations vis à vis the EU. This study analyses the progress made during these past 15 years and interprets it with regard to the future.

Just as important as the emission reductions already accomplished are those that must yet be achieved, for we still have a long way to go. In this investigation, as our time-scale for forecasting the future situation, we have selected the same period of time: a further 15 years. This is the period during which numerous of the measures so far undertaken will begin to take effect. 2020 is the year to which the next Kyoto commitment will probably relate. It is a little easier to survey the next 15 years than any longer periods of time, in that elaborate plans exist for the development of that most important of all renewable energy sources, wind energy. In addition, the funds approved under the Renewable Energy Sources Act are available throughout this period of time. And finally, this is also the approximate period within which the nuclear power plants are scheduled to be closed down under the provisions of the Atomic Energy Act amended in 2004.

For all of these reasons, the study covers a timescale of approximately 30 years extending from 1990 to about 2020. After that, new instruments of CO₂-free energy production will come into play. Besides the solar thermal power plants discussed in a later chapter, the most important of these is nuclear fusion. This is the subject of a clearly outlined development programme for a fusion power plant to supply electricity. The recent decision to build ITER [9] shows that the world's industrialised countries have resolved to collaborate in developing this very promising source of energy.

Notes and references for the Foreword

- [1] Memorandum 1995: *Zukünftige klimaverträgliche Energienutzung and politischer Handlungsbedarf zur Markteinführung neuer emissionsmindernder Techniken*, a statement by the Deutsche Physikalische Gesellschaft, March 1995. The energy lectures held at the major annual physics conferences are published as leaflets (obtainable from DPG, Bad Honnef, or from the publishers, Blum and Keilhacker); they can also be downloaded from <http://DPG-Fachgremien.de/AKE/index.html>, which also offers papers from the energy seminars that take place twice a year.
- [2] *Warnung vor weltweiten drohenden Klimaänderungen durch den Menschen, gemeinsamer Aufruf der DPG und der DMG*, Physikalische Blätter 43 (1987) p. 347

Notes and references for the Introduction

- [1] IPCC 2001: *Climate Change 2001, The Scientific Basis, Contribution of Working Group 1 to the Third Assessment Report of the Intergovernmental Panel on Climate Change*, Cambridge University Press, Cambridge, UK, and New York, NY, USA
- [2] Long-term average air temperature close to the ground in the northern hemisphere
- [3] For an assessment of the impact of climate change, see for instance IPCC 2001, Technical Summary F and chapter 9 ff. A good portrayal can also be found in the pamphlet on *Globaler Klimawandel* issued by Germanwatch, Bonn, Berlin (no date)
- [4] For comparison purposes: At the glacial maximum of the last ice age roughly 18,000 years ago (the Würm or Weichsel glaciation), the Earth was [2] 4 or 5 degrees Celsius colder than it is now (the reverse situation to the man-made climate disaster threatening us today), the Earth's ice cover was tripled by comparison with today, and the sea level was about 135 m lower [5].
- [5] See for example: C. Schönwiese, *Klimaänderungen*, Springer-Verlag, Berlin, Heidelberg, New York, 1995
- [6] See for example: *Mehr Zukunft für die Erde*, final report of the Enquete-Kommission into *Schutz der Erdatmosphäre* on behalf of the 12th German parliament, part B, chapter 4. Economia-Verlag, Bonn 1995
- [7] IPCC 2001, p. 47
- [8] National Climate Protection Programme of 18 October 2000, 5th report of the inter-ministerial working group on "CO₂ reduction"
- [9] ITER: International Thermonuclear Experimental Reactor

1 Evolution 1990 – 2020

1. Evolution from 1990 until now

Energy policies and targets for reducing carbon dioxide emissions

The declared aim of the German government's climate protection and energy policy is to provide a reliable and economical power supply that protects the climate, saves resources and is compatible with the environment, says the German government's paper on sustainability [1]. The paper does not underestimate the conflicting goals that currently exist, some of which it points out as examples: nuclear power, while delivering CO₂-free electricity, will not feature in future power supply plans due to the risks it involves; energy prices ought on the one hand to be kept high to encourage the economical use of energy, but on the other hand they need to be low not only for social reasons, but to enable German industry to survive in the face of international competition; moving a large share of the power supply from coal to natural gas would indeed greatly reduce CO₂ emissions, but would further endanger the reliability of the power supply by its dependence on imports, quite apart from destroying the domestic coal industry. The German government moreover insists that it will continue to play its pioneering role in developing and implementing an ambitious environmental policy. The key components of a sustainable climate protection and energy policy are considered to be improving efficiency in power utilisation and generation, and making greater use of renewable energy sources.

Within this framework, the German government has defined a number of targets for the reduction of greenhouse gas emissions from Germany. The most important of these are summarised in Table 1-2 below [2].

Total annual emission of carbon dioxide by Germany	-25% from 1990 to 2005	1, 2, 3, 4, 5, 6
Total annual emission of greenhouse gases by Germany in the EU	-21% from 1990 to 2008/12 (b)	7
Total annual emission of greenhouse gases by Germany in the EU (assuming that the EU decides on -30%)	-40% from 1990 to 2020	7, 9, 10
Interim goals	(included in the above)	
Reduction of specific CO ₂ emissions by the German industry (a)	-28% from 1990 to 2005	8
Reduction of specific Kyoto gas emissions by the German industry (a)	-35% from 1990 to 2010	8
Self-imposed commitment by the German government to reduce annual CO ₂ emissions in its own facilities (buildings, vehicles)	-25% from 1990 to 2005 -30% from 1990 to 2010	9

(a) Relative to the quantities produced

(b) The notation '2008/12' means 'on average for the five years from 2008 to 2012'

Table 1-2: National targets for reducing greenhouse gases and specifically CO₂

The first major national target of minus 25% from 1990 to 2005 related only to carbon dioxide. This target was fixed by the cabinet in 1995, formed part of the 1998 coalition agreement, was the central issue in the National Climate Protection Programme of 18 October 2000, and constituted a subject of the agreements between the German government and the German industry on 9 November 2000 and on 14 May 2001. But little more has been heard about this target since it has become clear that we are unable to meet it.

Measure	Million metric tons
Ecological tax reform	10
Programmes to promote energy saving in existing buildings	5 – 7
Measures relating to electricity consumption and tightening of the law on energy efficiency labelling	5
Tax concessions in mineral oil tax for low-sulphur fuels	2 – 5
Use of smooth-running oils and smooth-running tyres in newly licensed vehicles	3 – 5.5
Per-kilometre motorway toll for heavy goods vehicles	5
CO ₂ reduction in new vehicles / Agreement with the automobile industry	4 – 7
Energy saving directive for industry and small consumers	up to 6
Publicity campaigns and public awareness	5
Accelerated construction of combined-cycle power plants fuelled by natural gas	5 – 10
Combined heat and power generation / Introducing a system of quotas (subsequent agreement with industry)	in the order of 10
Renewable Energy Sources Act (EEG)	10
Forest management and conservation / Forestry development (carbon sink)	30

Table 1-3: Key measures of the national climate protection programme and anticipated effect of each measure on the reduction of CO₂ emissions by 2005

The National Climate Protection Programme published in 2000 is a 421-page document that bears eloquent testimony to the government's exceptional efforts to achieve the 25% target. It contains statistics for the emission reductions achieved up to that time. On the basis of the figures up to and including 1998, it was clear that it would not be possible to reach the 25% target without introducing additional measures. An impressive package of state initiatives was described – the list numbers 64 individual measures since the autumn of 1998. The most important of these are named in Table 1-3 [3], followed by the anticipated CO₂ emission reductions in million metric tons by 2005.

Unfortunately, the course of events since the start of the reduction initiatives has by no means fulfilled all of these expectations. In Fig. 1-1 the actual CO₂ emissions since 1990 are plotted as a graph [4] and compared with a straight line representing an even reduction rate [5]. It can be seen that, despite all efforts, the CO₂ emissions have failed to meet expectations. The nation's most important emission-reduction target can no longer be reached.

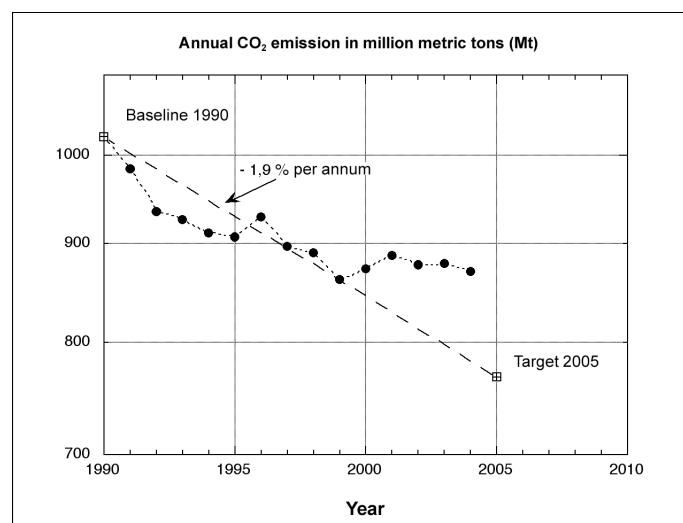

Fig. 1-1: The 25% target for CO₂ emissions, set against the actual situation

Overall reduction targets for Kyoto greenhouse gases as a whole

Even before the Kyoto Protocol came into force in February 2005, the European Union had pledged during the Kyoto process to achieve an 8% overall reduction of the relevant greenhouse gases ("Kyoto gases") for its own territory in the period from 1990 to 2008/2012, which means that the reduction target should be reached by the average over the five years from 2008 to 2012. (In this study the interval is generally substituted by the year 2010.)

Germany had the highest greenhouse gas emissions in the EU, both in absolute terms and per head of the population. As its part of the burden sharing within the EU, the Federal Republic of Germany therefore pledged to set a good example in reducing its greenhouse gas emissions by 21% from 1990 to 2008/12. The actual emissions of all Kyoto gases are plotted in Fig. 1-2 [12] and set against a hypothetical even development from the baseline to the specified target.

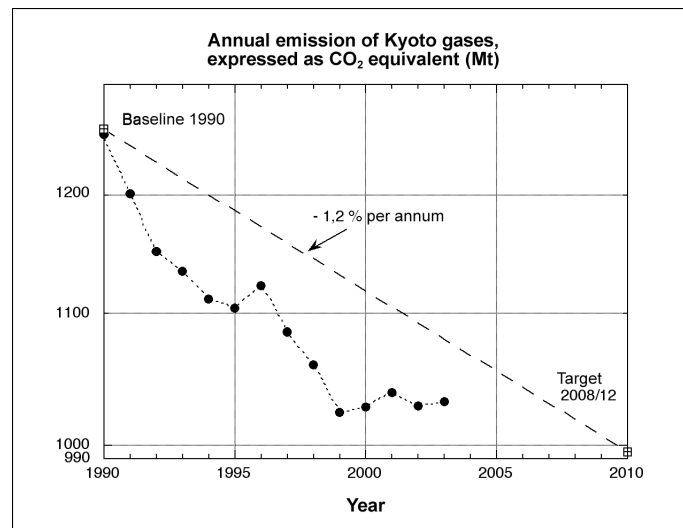

Fig. 1-2: The 21% target for Kyoto gases, set against the actual situation

The points on the graph follow a similar pattern to that in Fig. 1-1, carbon dioxide being the main component of the Kyoto gases, but they are in a more favourable position, namely below the straight line that represents the steady evolution up to the Kyoto commitment. Germany should be able to reach its target for the first commitment period, and even to exceed it if it continues its efforts at the same level. However, after evaluation of existing short-term trends, a more recent DIW study [6] concludes that the country is likely to fall short of the target by about one percent unless further measures are initiated. A comparison between 1990 and 2002 is shown in Table 1-4:

	1990	2002	Reduction
All Kyoto gases	1254 Mt	1029 Mt	17.9%
CO ₂ alone	1023 Mt	878 Mt	14.2%
all others except CO ₂	231 Mt	151 Mt	34.6%

Table 1-4: Annual emissions of greenhouse gases in Germany 1990 and 2002 in CO₂ equivalents (million metric tons) and the reductions achieved [7]

The data reveal three reasons why it seems possible to fulfil the Kyoto commitment but not the national target of 25% by 2005:

- (a) The Kyoto commitment is easier to fulfil than the national commitment, for it only calls for a reduction rate of 1.2% per year, while Germany's national target is 1.9% per year (the straight line for the Kyoto commitment is less steeply inclined).
- (b) The drop in CO₂ emissions includes elements that can be ascribed to special circumstances and are not likely to recur in this form, one of them being the rapid decrease of emissions in the first years after 1990 due to the collapse of industries in East Germany, and another being an increase in the nuclear share of power production at the expense of fossil fuels, accounting for roughly 1.4% [8].
- (c) The two most important greenhouse gases after carbon dioxide, methane and nitrous oxide, were considerably further reduced over the 12 years, by a percentage nearly two and a half times as great as that of the CO₂. This also means that their relative importance in the mix of greenhouse gases is lessening and that the real battle must now be waged against the core component, carbon dioxide.

Annual percentage changes in CO₂ emissions

Because of the numerous separate components of the strategy for cutting carbon dioxide emissions and the many individual decisions in technology and industry that ultimately bring about the reduction, we have chosen below to use a type of diagram that depicts the evenness of the development. The potential reductions for any given year must be set in relation to the emissions being discharged at that time. The reduction, expressed in absolute metric tons of CO₂, becomes progressively more difficult to achieve as the emissions grow smaller. To illustrate this principle, the changes that have already taken place will be characterised below as annual in CO₂ percentage changes [9].

100%	Total CO ₂ (2002: 878 million metric tons)	- 1.3% p.a.
18%	Industry	- 3.0% p.a.
41%	Power plants and district heating stations	- 1.2% p.a.
20%	Traffic and transportation	+ 0.7% p.a.
19%	Domestic and small-scale consumers	- 1.1% p.a.
2.6%	Others	

Table 1-5: CO₂ emissions and mean annual change as a percentage, 1990–2002

Table 1-5 shows the reductions achieved between 1990 and 2002 in the four main categories of emission source (the + sign indicates an increase). The greatest successes were achieved by industry, which by and large fulfilled its commitments to reduce emissions. The lowest degree of success – in fact, an increase in CO₂ emissions – is found in the traffic sector.

In order to give a clearer interpretation to the influence of CO₂ reductions stemming from German reunification, we have excluded the years 1990 and 1991 and expressed the data

from Fig. 1-1 for the years 1992 to 2004 as an even per-annum percentage change. The result can be seen in Fig. 1-3.

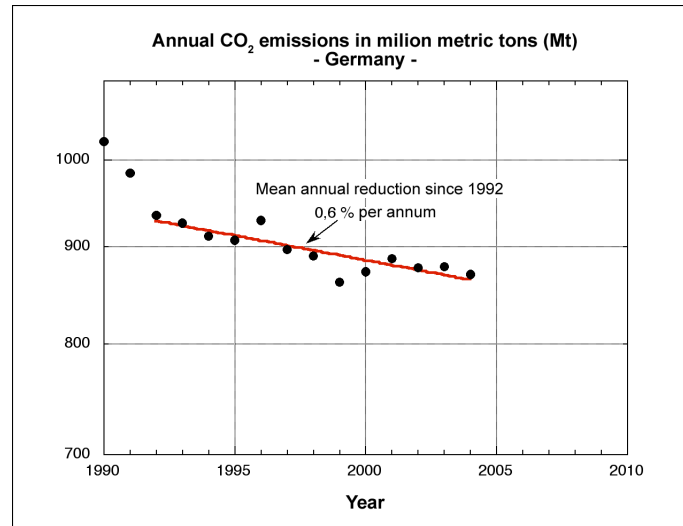

Fig. 1-3: The same data as in Fig. 1-1, but excluding the years 1990 and 1991 (special reductions due to reunification) in order to draw a straight line describing the mean annual reduction.

The straight line drawn between the points shows that the drop in CO₂ emissions over the 12 years from 1992 to 2004 can be described fairly clearly as a mean annual decrease of 0.6% per year. This result must be regarded as very disappointing for a project vigorously aiming at climate protection. 1.5% yearly from 1992 to 2005 would have been necessary in order to reach the national target for 2005. The reduction rate was two and a half times too slow.

The role of renewable energy sources in reducing CO₂ emissions up to now

The government has offered remarkable incentives to encourage the population to make use of renewable energy sources, and these incentives have indeed had a broad effect. More details will be provided in the relevant sections below.

The statistics in Figs. 1-1, 1-2 and 1-3 and in Tables 1-4 and 1-5 already include the renewable energy sources that have made a difference. For instance, renewable energy sources contributed over 50 terawatt-hours to the electric power generated in 2004; this reduced CO₂ emissions in the power plant sector by the respective amounts because fossil fuel power plants were in operation for a correspondingly shorter time. The points on the graphs reflect these reduced figures. Without renewable energy sources, the CO₂ emissions would have been even greater.

That Germany's CO₂ emissions should have dropped by only 0.6% per annum over the past 12 years is particularly disappointing in that this low figure is the end result of a tremendous effort. Neither the government nor industry can be accused of inactivity in improving energy efficiency and in introducing renewable energy sources. On the contrary, much has already been accomplished. But a great deal more remains to be done in order to tackle global

warming, this greatest challenge of our century. The time factor involved has been grossly underestimated. At this slow rate of reduction we will still be discharging 786 million metric tons of carbon dioxide in 2020 – that is, three-quarters of the figure for 1990. Yet that was Germany's target for 2005!

2. Future development through to 2020

Political targets

There is at present (mid-2005) no mandatory target for the reduction of Germany's greenhouse gas emissions beyond that of the Kyoto commitment (-21% from 1990 to 2010), but the German government has firmly resolved to uphold the commitments that it has so far undertaken and to carry them considerably further. *In the opinion of the German government, it is essential that the commitments made by the industrialised countries in the Kyoto Protocol for the first commitment period from 2008 to 2012 should be drastically intensified in the subsequent commitment periods.* [10] – It was in this spirit that the government announced its goal of a 40% reduction of Germany's overall annual emissions within the EU by the year 2020, which means achieving 60% of the 1990 baseline level, assuming that the EU as a whole resolves to set itself a target of 70% [Table 1-2]. The numerical relations of this proposal are shown in Fig. 1-4.

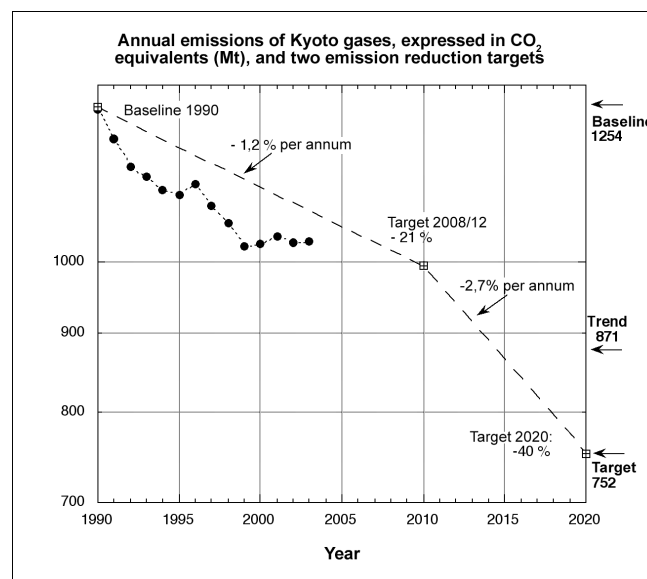

Fig. 1-4: German government proposal for a commitment within the framework of the EU, compared with the actual emissions until 2003 and the currently valid commitment. The baseline value, the extrapolated figure for the next time section, and the target for 2020 are marked on the right-hand scale.

The efforts have indeed been stepped up considerably; the idea is that during the period from 2010 to 2020, the annual percentage reduction rate should be twice as high as the rate that was actually achieved in the years between 1990 and 2003 [11]. One might justifiably wonder where any further potential for reduction exists, given that such a potential would have to supplement the ongoing reductions at their existing levels. This is the question that will be investigated below.

Continuation of the present reduction rate

In order to make a distinction between the different components, the principal greenhouse gases are shown separately in Fig. 1-5. Both carbon dioxide and methane exhibit a steady annual reduction over the period from 1992 to 2003 [12], while nitrous oxide emissions dropped very suddenly in 1997/99. It is worth noting the continuous annual decrease of the noxious methane gas by 4.3% p.a.. The regrettably low annual decrease in carbon dioxide emissions has already been commented upon. If these trends are extrapolated until the year 2020, the result is 871 million metric tons of CO₂ eq., or 69% of the level in 1990 [13]. This value was marked in Figure 1-4. (If the N₂O were in future to remain at the same level as during the last 5 years, the result would be 897 Mt or 71%.).

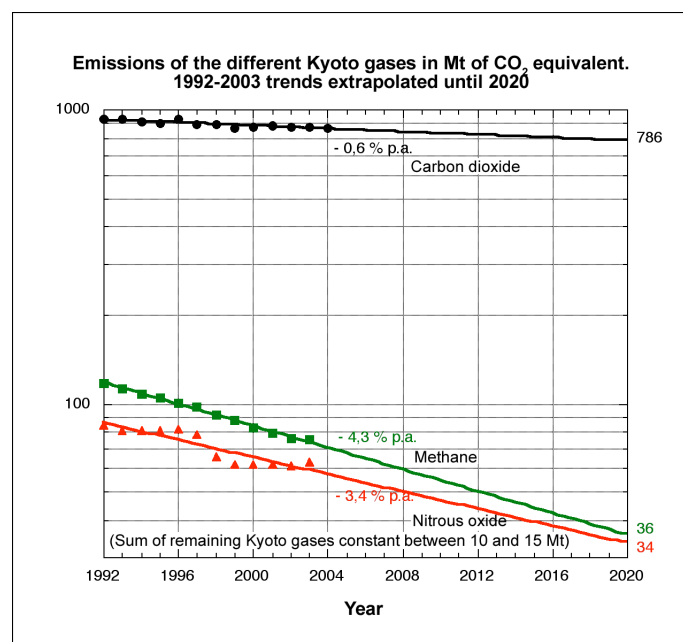

Fig. 1-5: Development of emissions of the three major greenhouse gases since 1992, the ending of special influences immediately due to German reunification and extrapolation of the trend for the last 12 or 13 years until the year 2020; an overall emission of $786+36+34+15 = 871$ Mt CO₂eq is expected for the year 2020

Of course it is not always possible to make a prognosis for the future by extrapolation from the past, least of all when one-off influences and measures come into play. We therefore need to investigate where we can expect to find factors that are likely to have a positive or negative effect on the trend. This will be discussed in the next nine chapters. Chapter 11 will draw up a balance between these trend-modifying factors, and it will become apparent which way the extrapolated value of 871 million metric tons of CO₂ equivalent can be expected to shift.

Taking the trend over the past 13 years as the basis for a prognosis until 2020 should not be confused with the attitude termed in the familiar scenario calculations as “business as usual”, i.e. a continuation of economic operations involving no particular effort to protect the global climate at all. We must remember that the trend of the CO₂ reductions over the past 13 years reflects an extremely dynamic development – the government has poured appreciable funding into climate protection measures, from heat insulation of buildings to the extension

of renewable energy sources. It is important to understand that “continuation of the trend” implies that this funding must continue to flow with the same intensity if the trend is still to apply to the immediate future. This means that annual investments must continue to be made at the same level, and the costs of avoiding CO₂ emissions must continue to grow at the same rate.

Notes and references

- [1] *Nachhaltigkeitsstrategie 2002: Perspektiven für Deutschland – Unsere Strategie für eine nachhaltige Entwicklung*, issued by the Press and Information Office of the German Federal Government, Berlin, April 2002, p. 107 ff.
- [2] Sources in Table 1-2:
- [2-1] Cabinet resolution 1995
- [2-2] Coalition agreement 1998
- [2-3] The German Chancellor at the 5th Conference of the Parties to the UN Framework Convention on Climate Change (COP5) in Bonn, 1999
- [2-4] National Climate Protection Programme 2000 (German government resolution of 18 October 2000)
- [2-5] Also included in the agreements between the German energy industry and the German government dated 9 November 2000 and 14 May 2001
- [2-6] National sustainability strategy 2002
- [2-7] see National Climate Protection Programme 2005 (German government resolution of 13 July 2005)
- [2-8] Quoted in National Climate Protection Programme 2000, p. 11. (Agreement of 9 November 2000)
- [2-9] Coalition agreement 2002
- [2-10] Announcement by the German government at the world climate summit in Buenos Aires on 15 December 2004.
- [2-11] National Climate Protection Programme 2000, p. 12. The second period is designated as 2008 to 2012 baseline year 1990 in the National Climate Protection Programme 2005.
- [3] *National Climate Protection Programme 2000*, Table 24. The present text cites only the items that were intended to save at least 5 Mt CO₂ by 2005. The overall sum in Table 24 came to 142-156 Mt CO₂ by 2005.
- [4] Energy data of the BMWA, Table 9 (January 2005). Data for 2003 and 2004 estimated with reference to H.-J. Ziesing, *Stagnation der Kohlendioxidemissionen in Deutschland im Jahre 2004*, newsletter 9/2005 of the German Institute for Economic Research (DIW) Berlin, S. 163, Table 2.
- [5] The vertical logarithmic scale was chosen because it enables comparable factors to be plotted as lines of the same length; this makes allowances for the fact that a reduction of, say, 3% at the beginning of the period appears just as great as a 3% reduction at the end.
- [6] *Klimaschutz in Deutschland bis 2030, Endbericht zum Forschungsvorhaben Politikszenerien III*, J. Diekmann et al. (DIW Berlin/FZ Jülich/ISI Karlsruhe/Öko-Institut), commissioned by the German environment ministry (502 pages), July 2004
- [7] Energy data of the BMWA, Table 10 (January 2005)
- [8] The annual output of electricity from nuclear power plants rose by 17.6 TWh from 1990 to 2002 thanks to efficiency improvements. Energy data of the BMWA, Table 22 (January 2005). Conversion by a factor of 0.8 kg CO₂/kWh results in 14 Mt CO₂. fraction $(1-q)^n$
- [9] If emissions decrease by the respective fraction q over n successive years, the will be achieved after n years. For example, in the first line of Table 1-5: $n = 12$, $q = 0.0127$. Total emission in 1990: 1023 Mt, and in 2002: 878 Mt (that is, 85.8%). $(1 - 0,0127)^{12} = 0.858$

- [10] *National Climate Protection Programme 2000*, p. 13; see also *Nachhaltigkeitsstrategie 2002*, p. 108.
- [11] Kyoto greenhouse gases 2003: 82.4% of 1990 value = $(1-0,0148)^{13}$ or 1.48% p.a.
- [12] The year 1992, two years after reunification, was chosen in order to exclude the immediate consequences of restructuring in the new *Länder*. Data sources for CO₂: [4], CH₄ and N₂O: newsletter 9/2005 of the German Institute for Economic Research (DIW) Berlin, p. 171, Table 6.
- [13] $786 + 36 + 34 + 15 = 871$. Given the annual fluctuations, the inaccuracy of extrapolation can be taken as roughly $\pm (30 \text{ to } 40)$ Mt CO₂ equivalent.

2 Saving energy at the point of consumption

The demand for energy is triggered by a demand for the effect that the energy will produce. Thus, in the first instance it is the temperature of the heated house which is required and only in the second instance the heating oil. In the first instance the brightness of light is needed, and in the second instance the electricity providing it. When the aim is to use energy as economically as possible, it is therefore the efficiency of the energy input for the required effect which is the decisive physical factor.

Using resources for the required purpose as economically as possible is one of the main driving forces of technology and business; the achieved optimum balance is represented by the state of the art at the particular time and the corresponding price structure. This is also the case for energy.

With the emergence of the problem of climate change, the parameters have changed and the *achieved* efficiency of energy use has to be compared with *what can be achieved*. This chapter will focus on potential for increasing efficiency on the consumption side – with particular emphasis on private households – while the next chapter will discuss the potential at hand in electricity generation by conventional power plants.

1. Existing energy-saving potential

There is still a long way to go before the physical limits of higher efficiency are reached. We can cite a number of examples which already cover a great deal of energy consumption:

Lighting

While a conventional light bulb provides a luminous efficiency of about 10-12 lumen/watt and the luminous efficiency of halogen spotlights is only slightly higher at 14-16 lm/W, fluorescent lamps in compact form yield a relatively good 50 lm/W. Values around 100 lm/W can be achieved by optimising fluorescent lamps and by using electronic ballasts. Comparable levels of efficiency are attained by using low-pressure metal-vapour lamps. By applying a reflective surface to the spine, the luminous efficiency can be improved even more. Dimmable lighting systems combined with brightness and movement sensors can produce a further reduction in consumption of up to 40%. Recent developments in organic light-emitting diodes have the potential to make even lower levels of consumption possible in light generation. Innovative light guides take daylight into buildings and do not use any electricity at all.

Communication

The use of personal computers at the peak of their technical performance capability leads to a distinct increase in the electricity they consume. Together with monitors and printers, average power inputs of up to 500 W are common. By using power-saving technologies as installed in

portable computers, however, it is possible to reduce the power consumption of flat screens and printers to below 100 W.

Standby losses

The standby losses of modern electronic equipment have caused a distinct increase in the power consumption of private households, businesses, the public administration sector and universities. The use of low-voltage halogen spotlights with no power switch also leads to unnecessary standby losses. It is very common for electrical equipment to consume 10-20 W in standby mode, although modern integrated circuits can reduce consumption to 0.1 W per unit of equipment. Electrical equipment in private households is estimated to consume around 20 TWh per year in standby mode [1], which represents close on 15% of total energy consumption in this sector. Including trade and commerce, the possible energy-saving potential is put at 25-30 TWh per year [2], the equivalent of emissions amounting to 18-21 Mt CO₂ per year.

Electric motors

Owing to hydraulic deficiencies and incorrect dimensioning, the electric motors used to operate pumps, extractor fans and cold storage appliances are often highly inefficient. By taking steps to remedy these deficiencies, the specific power consumption of such equipment can be reduced by a factor of 5-30 [3]. The corresponding energy-saving potential of private households, trade and commerce as well as in parts of industry amounts to 50 TWh, which is equivalent to about 10% of total power consumption in Germany and a reduction in emissions of 35 Mt CO₂ per year.

Motor cars

Whereas the average fleet consumption amounts to about 8 litres of petrol or diesel fuel per 100 km, cars are already available on the market that offer a consumption of 3 litres per 100 km [4]. Experimental cars powered by fuel cells achieve even lower levels of consumption. This subject is addressed more fully in Chapter 7.

Space heating

Whereas the energy required to heat traditional existing properties lies typically between 75 and 475 kWh/m²a, with an average value of 225 kWh/m²a (see Fig. 2-2 below), consumption levels of around 70 kWh/m²a have to be achieved in newbuild properties in Germany under the country's new energy-saving regulations. Wide-ranging experience with passive solar design shows that with reasonable additional expenditure houses can be built which achieve a consumption level of only 10-30 kWh/m²a [5]. Also, the construction of "zero-energy houses" has been demonstrated in principle but has not yet proved commercially viable. In these heavily insulated houses, the additional heat and power requirement is covered by

renewable energy (solar collectors, photovoltaic and biomass). The first demonstration projects show that modernisation measures can reduce energy consumption by up to 90% in the old building stock too. It is now widely acknowledged that the modernisation of old buildings plays a key role in curbing global warming. *Referred to the present housing stock, the realistic potential for the energy saving which can be achieved in old buildings by replacing inefficient heating systems and improving thermal insulation is estimated at 55 to 70 million metric tons of CO₂*, according to the experts of the Enquete Commission [6]. In estimating the total potential, however, the additional emissions caused by new buildings have to be deducted.

The examples from these selected consumption sectors indicate that there is still a long way to go before the physical limits of energy saving will be reached.

2. Actual rates of decrease in buildings

30% of the total end energy consumed in Germany each year (9288 PJ in 2002) is used by private households, 87% of it for heating and hot water [7]. These two factors thus account almost entirely for the CO₂ emissions caused by private households, which are plotted in Fig. 2-1 as a function of time [9]. Between 1990 and 2003, emissions decreased by only approx. 0.5% per year, a figure that is statistically hardly significant.

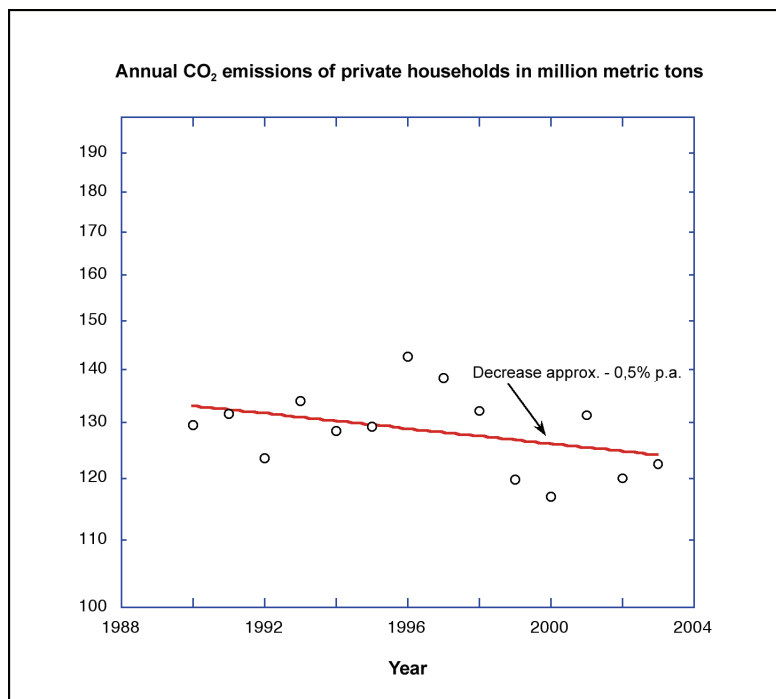

Fig. 2-1: Annual CO₂ output of private households in million metric tons.
The straight line is a description with the purpose of levelling out the annual fluctuations and indicating the approximate trend. The decrease in emissions of 0.5 % per year is statistically not very significant.

The following data are based mainly on the work of Kleemann [8]. The energy for space heating and hot water is used with various degrees of efficiency. Fig. 2-2 shows the frequency distribution of the energy consumed annually per square metre of floor area. 90% of all

consumption comes within the range of 75 and 475 kWh/m²a. For the purpose of comparison, the standard laid down in Germany's new energy-saving regulations (EnEV) for new buildings is also shown. Only 5% of the total floor area consumes less than this new standard (70 kWh/m²a). The problem is that the modernisation of the existing building stock to save heating energy is a long and expensive process. The normal renovation cycle takes 40 to 60 years.

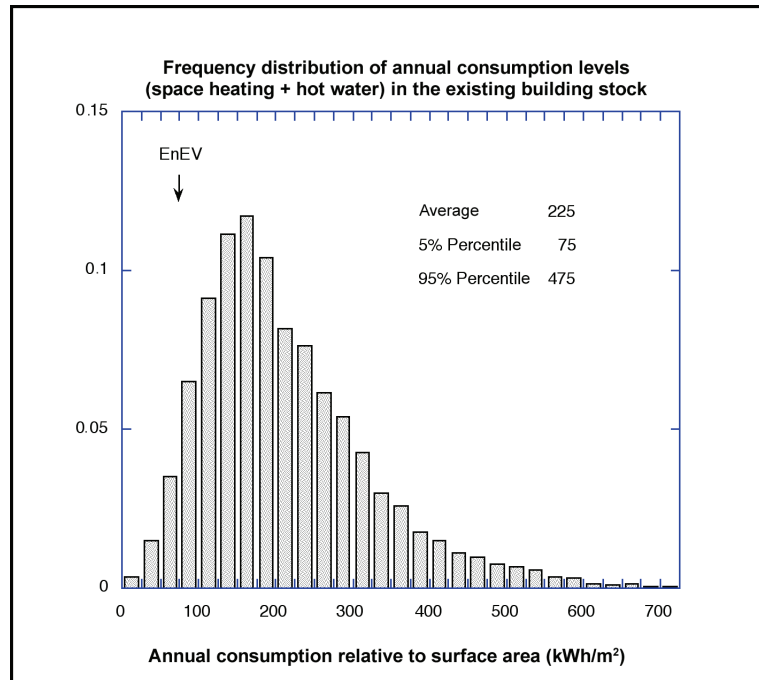

Fig. 2-2: Measured annual consumption figures for energy for space heating and hot water, as a function of floor area, in a major German city (all house sizes and age classes) [8]. The sample can be applied to the entire housing stock in Germany. The standard laid down for new buildings by the new Energy Conservation Ordinance (EnEV) is also shown.

The extremely slow decrease in emissions, which can hardly be distinguished from stagnation, is attributable to the fact that new buildings only accounted for about 1% per year of the total existing floor area and there was an even smaller proportion of old building demolition. At the same time, the rate at which old buildings were renovated was inadequate. Home owners spent about 11 billion euros per year on improving thermal insulation and replacing inefficient heating systems, which averaged out at a renovation rate of 24 million square metres a year. In most cases this was in connection with building rehabilitation work which was already taking place.

In analysing the question as to what investment has to be made in order to reduce CO₂ emissions even further, Kleemann studies a scenario that would reduce annual CO₂ emissions by 17 Mt CO₂ by the year 2020. It requires annual energy-related investments of 29 billion euros per year (instead of 11 billion euros up to now), which after an initial phase would have to be made in the years 2010 to 2020. As a result, 65 million m² of floor area (instead of 24 million m² up to now) would be renovated each year to save energy. The study makes allowances for renewing the least energy-efficient building stock first. An “annual metric ton of CO₂” (i.e. a metric ton of CO₂ saved annually by modernisation over the service life of 40 to 60 years) is estimated to require an investment of 13,000 euros.

One has to ask by which ways and means homeowners could be encouraged to treble their commitment to energy-saving in the coming years by increasing their annual thermal insulation and heating system investment from 11 to 29 billion euros.

In the past, financial incentives were provided in the form of tax credits and write-offs. Later, low-interest loans were granted from public funds through the Kreditanstalt für Wiederaufbau (KfW), which were less of a burden on the public sector, i.e. less public money had to be expended for each investment sum qualifying for support. Between February 2001 and March 2005 around 75,000 loans amounting to 4.2 billion euros were approved for improving the energy efficiency of approximately 223,000 dwelling units (approx. 18 million m²) [9]. In four years this represented 0.6% of the total floor area amounting to approximately 3 billion m². If these figures are extrapolated, we see that it would take 66 years to modernise just 10% of the total floor area by this method of funding. A much higher level of financial support than hitherto would have to be provided every year to realise a programme of the type envisaged in the previous two paragraphs. The provision of financial incentives for building renovation projects is one of the most important instruments of climate change policy. Germany's National Climate Protection Programme 2005 and other plans announced by the federal government do not indicate any prospect of such a high level of subsidies; it is even possible that the present funding scheme might be cut back for lack of budgetary resources.

The regulatory framework is subject to constant evolution. Over the past 30 years, the statutory regulations concerning the thermal insulation of buildings have been tightened up on average every six years and the prescribed energy consumption levels for heating have been reduced by a factor of five over this 30-year period. The Energy Conservation Ordinance (EnEV) which came into force in 2002 replaces the 3rd Thermal Insulation Ordinance of 1994 and the Heating System Ordinance of 1998. The new regulations were not only tougher but also included for the first time a primary-energy approach which takes into account the use of renewables in the home and their importance for reducing CO₂ emissions. The regulations on energy saving can be expected to develop further in future. There is plenty of scope on the technical side, especially as far as insulation is concerned.

The following discrepancy needs to be mentioned, however: If, according to experience and based on the technical service life of the individual components, the renewal cycle of the building stock is assumed to take 40 to 60 years, every year there will be a certain number of houses requiring renovation. In order to comply with regulations, such projects necessarily involve improvements to thermal insulation and the replacement of inefficient heating systems, producing energy savings which can be precisely calculated. The annual energy saving actually achieved, however, is just a fraction of the calculated figure. This "renovation efficiency" is a figure in the region of 0.37 or 0.33 rather than 1 [10]. It is also referred to as "inadequate execution" and can be regarded as a measure of the extent to which renovation activity can be controlled by official means. In any event, it should not be imagined that the level of necessary investment can be raised simply by "sending in the building inspectors".

In line with the deliberations in the first chapter, we are looking for factors of change which would cause the trend in emissions in the 15 years that lie ahead to move more quickly or more slowly than in the preceding period. It can be stated that currently no major changes can be seen emanating for the second half of the period under review, either from the

regulatory measures or from government financial incentives. On the contrary, we can expect the present trend to continue. Although in principle great potential exists for saving energy, the positive results for climate protection that are achieved by ongoing measures to improve energy efficiency in buildings are likely to be offset to a large extent by new building developments. In various expert assessments [11, 12, 8] the future proportion of newbuild is estimated at 0.8% to 1.1% per year of the existing building stock.

3. Energy prices

A new situation would arise if energy prices were to increase to a significantly higher level. The present oil price on the world market is three times higher than in the decade from 1991 to 2000, while the heating oil price for households in Germany is about twice as high. Heating costs (like petrol prices) are starting to hurt consumers.

Permanently high energy prices would represent a useful ally in the fight against climate change. They would generate direct pressure towards increased investment in modernisation projects. In this context it is significant that, even at the price level of recent years, many modernisation projects aimed at increasing energy efficiency – some implemented, some postponed – were very close to being profitable. This is the case not only for heating energy, but also – in a similar way and to differing extents – for most of the many uses of energy that exhibit high energy-saving potential [13].

If a situation arose in which prices for certain energy sources were to reach a consistently much higher level in the second half of the period under review (2005-2020) than in the first half (1990-2005), we would have to insert a trend-modifying factor in our forecast. As we cannot predict how prices will develop, nor the elasticity of demand for more-expensive energy, we will not do so. An increase in the cost of energy need not necessarily come from the world market, it could also be the result of a policy in which, for instance, the effect of the tradable CO₂ emission permits were extended to the end-consumer sector.

4. Research and development

The technical aspects of thermal insulation itself can be further improved. Research and development is being conducted on **innovative insulating materials**, see for example [14], which are better by a factor of 10 than the best industrial foam materials (i.e. only one tenth of the thickness for the same thermal transmittance coefficient or U-value). Promising results are also being achieved in research on adaptive insulating materials: their insulating properties can be made to adapt to changing temperatures, increasing thermal conductivity to take advantage of solar radiation during the day and reducing the rate of heat transfer when the air cools down at night. If these developments can be successfully brought to market one day, they could give a boost to modernisation projects and the construction of energy-saving houses.

The development and testing of a building technique known as 'passive solar design' has advanced very successfully over the past 20 years [5]. These houses are built using heavily

insulated components designed to minimise energy consumption for heating. The windows and their frames are especially important. The required heating energy is so low that it can be distributed to the rooms through the fresh-air ventilation system. An adequate number of such dwellings now exist for statistical criteria to be applied, enabling the thermal properties as well as the behaviour and well-being of the users to be systematically studied. The annual consumption of energy for space heating in 140 dwelling units has been measured. The mean value amounted to 16.6 kWh/m²a with a dispersion of ± 8 kWh/m²a. The progress that this represents can be gauged by comparing these values with those in Fig. 2-2, where they fall within the leftmost column of the bar chart [5a]. Thermal comfort measurements and questionnaires completed by the occupants confirm that no sacrifices have been made in terms of comfort. Low-energy homes of this type are not necessarily much more expensive than conventionally built properties, especially when the components, at present still custom-made, can be manufactured on a large scale. The same technique can be used to build multi-storey buildings, office buildings, schools, semi-detached and detached houses. *Any type of property can be built using the principles of passive solar design, on condition that the structural and technical quality requirements are observed*, writes W. Feist [5].

Notes and references

- [1] ISI: *Current and future energy demand of appliances in German households 1997-2000*; Karlsruhe December 2000
- [2] Prognos: *Analysis of the Effectiveness of CO₂ Reduction Measures in the Energy Sector and their Further Development up to 2015*, final report; commissioned by the Federal Ministry of Economics and Labour (BMWA), Basle August 2004
- [3] Empirical data supplied by Plenum, Hamburg, based on its experience as an industrial consulting firm.
- [4] M. Dick, *Die Technik des 3-Liter-Autos*, paper presented at the Dresden 2000 Physikertagung, published in: *Energie, Plutonium, Strom und die Umwelt*, ed. W. Blum, Deutsche Physikalische Gesellschaft, Bad Honnef
- [5] W. Feist, Passivhaus-Institut Darmstadt, *Energieeffizienz bei Gebäuden – dargestellt am Beispiel Passivhaus*, paper presented at the Hanover 2003 Physikertagung, published in: *Optionen für die Energie der Zukunft*, 11 papers at the Hanover conference, ed. M. Keilhacker, Deutsche Physikalische Gesellschaft, Bad Honnef. The article contains numerous details and further references.
- [5a] The figure relates exclusively to space heating, not including hot water.
- [6] Opinion of the CDU/CSU and FDP parliamentary parties and their expert advisers in the report of the Enquete Commission, parliamentary publication 14/9400, p. 541, cited by [DIW], p. 108
- [7] Energy data of the Federal Ministry of Economics and Labour (BMWA), Tab. 7, 28
- [8] M. Kleemann, FZ Jülich, *Aktuelle Einschätzung der CO₂-Minderungspotenziale im Gebäudebereich*, expert opinion commissioned by dena and the Federal Ministry of Economics and Labour (BMWA), Jülich, Nov. 2003
- [9] National Climate Protection Programme 2005
- [10] See [8], and the details added verbally by Mr Kleemann.
- [11] Prognos, EWI, Energy Report IV, *The Trend of Energy Markets up to the Year 2030*, commissioned by the Federal Ministry of Economics and Labour (BMWA), April 2005
- [12] IER, Prognos, *Analysis of the Effectiveness of CO₂ Reduction Measures in the Energy Sector and their Further Development up to 2015*, commissioned by the Federal Ministry of Economics and Labour (BMWA), August 2004

- [13] As a general rule, consumption in private households is less sensitive to price differences than in the case of business and industry users. Empirical studies show that private individuals frequently do not behave 'economically' because they have different motives.
- [14] J. Fricke, Würzburg, *Energiebedarf und Energiebereitstellung – Forderungen und Beiträge aus der Wissenschaft, insbesondere zur Altbausanierung*, paper presented at the Hamburg 2001 Physikertagung, published in: *Energie für die Zukunft*, ed. W. Blum, Deutsche Physikalische Gesellschaft, Bad Honnef

3 High-efficiency fossil-fired power plants

1. The present role of fossil-fired power plants in Germany's electricity supply

Fossil fuels are the backbone of Germany's energy supply. According to preliminary figures from the Working Group on Energy Balances, in 2003 they contributed 12,156 PJ (414.8 million tonnes coal equivalent or t.c.e.) and thus covered 84.1% of the country's primary energy consumption, mainly supplemented by nuclear energy which accounted for 12.5%. Hydroelectric and wind power covered altogether 0.9% of demand, and the rest was accounted for by "Others" (e.g. firewood, sewage sludge, refuse) [1]. Burning fossil fuels is also the main cause of greenhouse gas emissions.

3,420 PJ (= 116.7 million c.e.) or around 28% of total consumption of fossil fuels is attributable to power generation. A further 8.3% is consumed outside the energy sector as a chemical feedstock ("non-energetic consumption"). The remaining 64% is shared roughly equally by transport and heating. As far as the aim of reducing greenhouse gas emissions is concerned, the electricity sector, transport and the heating market therefore deserve equal attention.

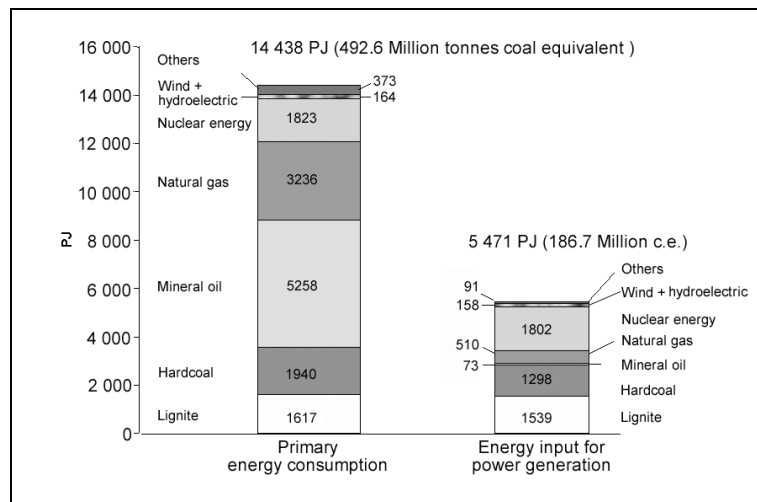

Fig. 3-1: Primary energy consumption [2] and energy input for power generation [3] in Germany in 2003 by fuel type

The relative proportions of fossil fuels used in the electricity sector is considerably different from the structure of primary energy consumption as a whole. In primary energy consumption, mineral oil (36.4%) and natural gas (22.4%) dominate, well ahead of hardcoal (13.5%) and lignite (11.4%). In the electricity sector, hardcoal and lignite are by far the predominant fuels; natural gas accounts for less than 10%, but its share will increase in future, while oil products play a very minor role. As far as the security of supply is concerned, therefore, the electricity sector is in a relatively favourable position, and coal reserves will last much longer than those of oil and gas. The use of lignite and hardcoal does, however, entail the highest specific emissions of CO₂.

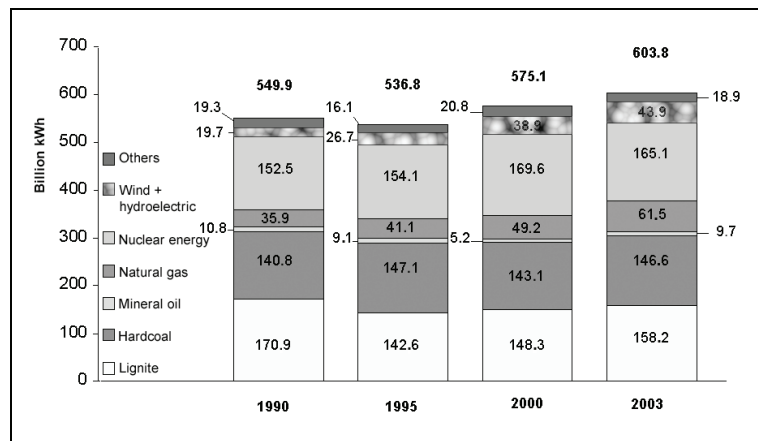

Fig. 3-2: Power generation in Germany 1990 – 2003 by energy source [4]

While primary energy consumption has been stagnating in Germany since 1990, electricity consumption has risen by about 10% over the same period. The higher demand has mainly been met by increased use of natural gas and wind power and by generating more nuclear and hydroelectric power. Electricity generation from lignite and hardcoal has remained roughly constant. At 376 billion kWh, fossil fuels accounted for 62.3% of power generation in 2003. Gross power consumption in Germany (including network losses) amounted to 595.8 billion kWh in 2003.

2. Outlook for power generation from fossil fuels

In our deliberations on reducing emissions from fossil power generation, we make the simplifying assumption that electricity generation from fossil fuels will remain at roughly the same level as today. To the extent to which nuclear power will be reduced, fossil-fuelled power generation will have to be increased, and to the extent to which additional electricity will be available from renewable sources and will outstrip the rise in demand, power generation from fossil fuels will be reduced.

If, however, no significant decrease in power generation from fossil fuels is to be expected by 2020, the decisive question is whether, and if so, to what extent specific CO₂ emissions from fossil fuel power plants per kilowatt hour can be reduced by 2020. Two measures are available for this:

- Further improvement in the efficiencies of fossil-fired power plants, which will reduce fuel consumption and CO₂ emissions per kWh, and
- Increased use of lower-carbon fuels, i.e. replacement of coal by natural gas.

In the long term, i.e. not before 2020, technologies will also be available for the separation and disposal of CO₂ which will permit virtually CO₂-free generation of electricity from fossil fuels (cf. Chapter 9).

To a limited extent, efficiency-improving measures can be implemented in existing power plants. Such measures have already been carried out on a large scale, in particular with the

modernisation of steam turbines. In some power plants, efficiency has been increased by installing a natural gas-fired turbine upstream of a coal-fired steam boiler and using the hot waste gas as combustion air for the steam boiler. Appreciable increases in efficiency can, however, only be achieved by replacing old plants with state-of-the-art technology.

In this respect we find ourselves at present in a uniquely favourable situation, because in the period up to 2020 a large part of fossil power plant capacity will have to be renewed for reasons of age. The first newbuild projects for modern fossil-fired power plants are already underway, including coal-fired steam power plants as well as natural gas-fired combined-cycle gas and steam turbine power plants.

3. Potential efficiency improvements to fossil-fired power plants

Since the beginnings of power plant technology, one of the great and ongoing tasks for the engineer has been to increase efficiency – originally just for economic purposes, i.e. to save fuel costs. Today, environmental protection and pollution control are further major driving forces behind this aim.

Over the past 40 years, the efficiency of lignite power plants has been increased step by step in parallel to the increase in unit output, mainly by raising the steam conditions as well as by further developing steam turbine technology and the power plant processes [5]. In new lignite power plants being built today, the present state of the art permits an efficiency of 43% [6]. Developments in hardcoal power plant technology have been similar and today an efficiency of 46% is possible [6].

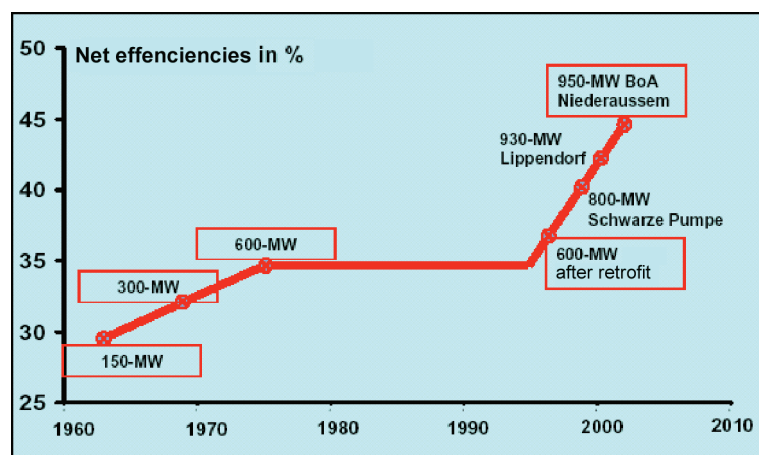

Fig. 3-3: Net efficiencies of newbuild lignite power plants [5]

The Niederaussem BoA power plant (BoA = lignite power plant with optimised plant technology), which came on stream in 2003, has an efficiency of 43% and replaces old facilities with an efficiency of about 32% [5]. Its specific fuel consumption is therefore a good 25% lower than that of the old units. Even just replacing old plant with today's technology would make a notable contribution to pollution control.

The development of combined-cycle gas and steam turbine technology has been even more spectacular. Whereas the first plants, such as the Munich-South combined heat and power plant achieved an efficiency (not including heat output) of 40% at the beginning of the 1980s, a level of 58% can be reached today, likewise not including the heat output [6]. By replacing an old hardcoal power plant with a modern natural gas-fired combined-cycle gas and steam turbine power plant, fuel consumption could therefore be reduced by nearly half and CO₂ emissions per kWh cut to only 35% of their original level.

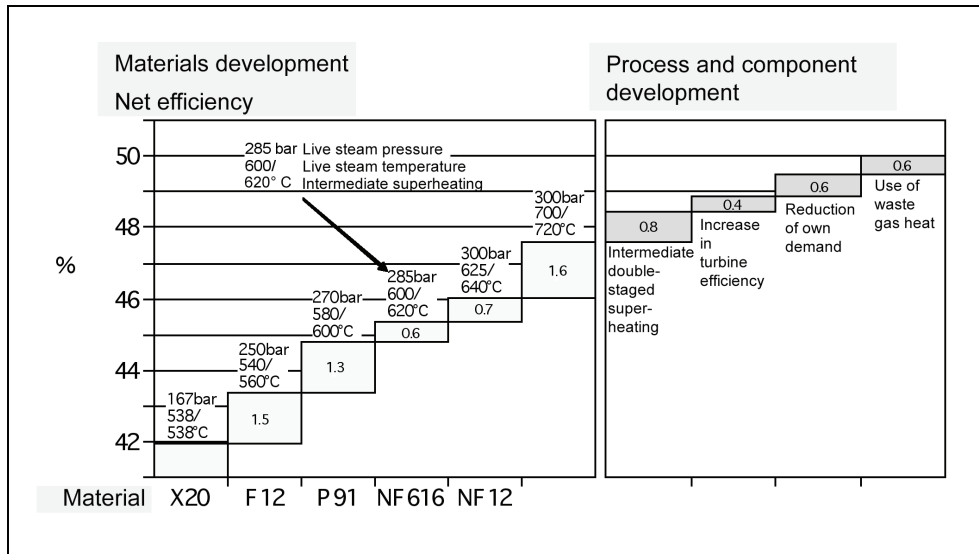

Fig. 3-4: Development potential of coal-fired steam power plants [7]

And there is still potential to exploit. Current further developments are aimed at a further increase in efficiency. For steam power plants they focus on:

- the development of new materials capable of withstanding higher steam conditions, and
- process and component improvements to reduce heat losses.

Today's P91 steel permits steam conditions of 580°C and 270 bar. To be able to control supercritical steam conditions of 700°C and 300 bar, nickel-based alloys are needed. Corresponding development programmes are underway, supported by the EU. Process optimisations such as intermediate double-staged superheating and utilisation of heat from refuse incineration have already been put into operating practice. These will be joined by component optimisations such as improvements to the turbine flow technology and generator cooling. Efficiencies of 53% are regarded as achievable by 2020.

Similar approaches are being pursued in the development of combined-cycle gas and steam technology with the aim of achieving an efficiency level of around 62%. As far as the materials are concerned, this work focuses on gas turbine blade materials with a high nickel content and monocrystalline structure, as well as on special coatings to protect the blades from corrosion and the temperature of the hot gas. Other developments are geared to reducing the required quantity of cooling air for the gas turbine blades and on the use of steam cooling.

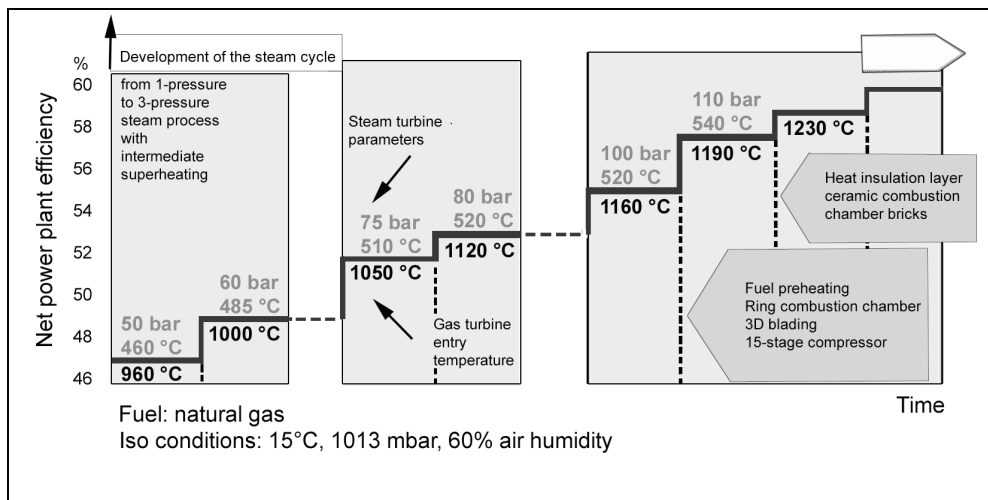

Fig. 3-5: Development potential of natural gas-fired combined-cycle gas and steam turbine power plants [7]

This work is part of a new research concept pursued by the Federal Ministry of Economics and Labour (BMWA) with the aim of building low-emission fossil fuel-fired power plants (COORETEC Concept). The BMWA is being supported by expert groups from the manufacturing industry, electric utility companies, research institutes and universities [8]. The concept provides for a phased procedure:

- The short- and medium-term aim is to vigorously develop power plants on the basis of the existing technologies in order to realise the most quickly usable potential for reducing CO₂.
- In parallel, additional R&D activities for innovative power plant concepts will be advanced to make further increases in efficiency and reductions of CO₂ possible in the medium and long term, including the option of CO₂ separation.

A general point should be mentioned concerning the target values stated for power plant efficiencies: These values are to be understood as nominal values on the rating plate of the plant and applied to the plant in new condition, under optimal cooling conditions and in continuous operation at the most efficient level near to full load. In operating practice, deductions have to be made for aging, cooling tower use, summer operation, part load and load sequence operation, etc. As the future modes of operation for fossil-fired power plants under changing conditions on the electricity market and above all the increasing share of renewable power generation are not known, we will apply an overall deduction of 2 percentage points.

4. Estimate of the reduction in CO₂ emissions achievable in the electricity sector by 2020

The baseline is the situation in 2003, as presented in Table 3-1. The figures are based on the tables for gross power generation and for fuel input stated in [3] and [4]. The comparable figures for 1992 show, among other things, the improvements in efficiency achieved during this time and the resultant decreases in CO₂ emissions per kWh. (1990 is not suitable as a

comparative year because the closures of the overhang from obsolete lignite power plants after German reunification had not yet taken place.)

Fuel	Hardcoal		Lignite		Natural gas		Fuel oil		Total	
	1992	2003	1992	2003	1992	2003	1992	2003	1992	2003
Year	1992	2003	1992	2003	1992	2003	1992	2003	1992	2003
Gross power generation Billion kWh	141.9	146.6	154.5	158.2	33.0	61.5	13.2	9.7	342.6	376.0
Fuel input in power generation PJ	1285	1298	1617	1539	278	(461)	(140)	(100)	3320	3398
Gross efficiency (average), %	39.75	40.66	35.24	37.01	42.73	48 ¹⁾	34 ¹⁾	35 ¹⁾	37.15	39.84
Specific CO ₂ emissions, g CO ₂ /kWh	830	812	1135	1081	445	396	882	857	-	-
Total CO ₂ emissions, million tonnes CO ₂	117.8	119.0	175.4	171.0	14.7	24.4	11.6	8.3	319.5	322.7
Average specific CO₂ emissions from all fossil-fired power plants, g CO₂/kWh									932.6	858.2

¹⁾ Literature values, as the data on fuel input are not available in enough detail. Figures in brackets on fuel input are calculated back from the efficiencies.

Table 3-1: Baseline data for 2003 with comparable figures for 1992

For the period 1992-2003 we can therefore register an efficiency gain of 8.0% in terms of specific CO₂ emissions caused by fossil power generation. Apart from modernisation work on existing facilities, this was mainly due to the replacement of old lignite power plants in eastern Germany, but also in part to the increased use of natural gas in power generation. The trend factor of 0.9203 between 1992 and 2003 corresponds to an annual decrease in specific emissions of 0.752% per year. Owing to the expansion of fossil power generation, however, CO₂ emissions increased by around 1% in absolute terms.

In estimating the further efficiency gains to be expected by 2020, we have intentionally avoided taking a preferential view of any of the specific energy scenarios under discussion, and not developed any scenarios of our own. Instead, in the interests of providing a model that can be applied to any scenario, we have assumed that power generation from fossil fuels will remain unchanged compared with 2003, at 376 billion kWh.

In two separate stages, we set out to examine the possible reduction in CO₂ emissions that could be achieved by replacing old power plants with new ones:

- 1st stage: Unchanged shares of the individual fuels in fossil power generation.
- 2nd stage: Increase in the share of natural gas to the detriment of coal.

For this purpose, the following assumptions are made for stage 1:

- In 2020 half of the electricity produced using hardcoal, lignite, natural gas and fuel oil will be generated in new plants which will come on stream between 2010 and 2020. The other half will be generated in plants which currently exist and which will not yet have been replaced, i.e. the more recent half of today's installed capacity. On this basis, the average efficiency is calculated as 42% for hardcoal, 41% for lignite, 50% for natural gas and 36% for fuel oil [8]. (At the end of 2003 the bottleneck output of fossil-fired power

plants amounted to around 77,000 MW [9], of which around 38,500 MW will be replaced by 2020 according to this model calculation.)

- For the efficiencies of new plants, the following average values are applied: Hardcoal power plants 47%, lignite power plants 46%, natural gas power plants 58%, fuel oil power plants 38%. In estimating these values it was assumed that the expansion and replacement power plants will steadily come on stream in the period 2010 to 2020 and will incorporate the latest technology demonstrated in reference plants. Also, the deduction mentioned in Chapter 2.3 for non-optimal operation is made. (All efficiency figures are gross values, like the power-generation figures.)

The mixed level of efficiency taken in each case from a fleet consisting of 50% old and 50% new plants is, of course, below the efficiencies of the corresponding new plants. It would not be economically sensible to replace as well, ahead of time, the younger half of the present power plant stock, especially as the attainable improvements in efficiency would turn out to be lower. Based on these assumptions, the following structure is calculated for fossil power generation and the associated CO₂ emissions for 1992, 2003 and 2020:

	1992	2003	2020 old	2020 new
Hardcoal				
Gross power generation, %	41.4	39.0	19.5	19.5
gCO ₂ /kWh	830	812	790	702
Lignite				
Gross power generation, %	45.1	42.1	21.0	21.0
gCO ₂ /kWh	1135	1081	976	870
Natural gas				
Gross power generation, %	9.6	16.4	8.2	8.2
gCO ₂ /kWh	445	396	380	328
Mineral oil				
Gross power generation, %	3.8	2.6	1.3	1.3
gCO ₂ /kWh	882	857	833	789
Total fossil				
Gross power generation, %	100	100	50	50
gCO ₂ /kWh β	932.6	858.2	802.0	713.5

Reduction factor from 1992 to 2003 = 0.9202; trend factor extrapolated from it from 2003 to 2020 = $0.9202^{10/11} = 0.8794$; 2020: β = 757.7 gCO₂/kWh; reduction factor 2003 to 2020 = 0.8831

Table 3-2: Reduction in specific CO₂ emissions from 1992 to 2003 and, with the same fuel mix as in 2003, through renewal of half of the power plant stock by 2020

As a result, the specific CO₂ emissions from the electricity sector in 2020 would be 11.7% lower than in 2003 with the individual fuels accounting for the same supply share. This represents an annual decrease of 0.73%. Even with intensive power plant renewal, therefore, the trend for the years 1992-2003 will not quite be reached. Nevertheless, it should not be overlooked that the trend for 1992 to 2003 was also influenced by an expansion of the share of natural gas which was accompanied by a significant increase in the efficiency of natural gas-fired power generation with the advances in combined-cycle gas and steam turbine technology.

Consequently, in the second stage we go on to examine what additional reduction in emissions might result if we assume that the supply share of natural gas will increase to the

detriment of coal in the period 2003 to 2020. Seen in terms of pollution control, a rise in the share of natural gas is advantageous, but there are three arguments against it, so that only limited expansion is realistic:

- Natural gas is more expensive than coal and experts reckon that it will get even more expensive.
- Given the dominance of Russian natural gas deposits, there are doubts about the security of supply.
- The reserves of natural gas are much smaller than those of coal.

Experts forecast that the share of natural gas in fossil power generation will increase to a maximum of 32% by 2020, which represents almost a doubling on 2003 when the share was 16.4% [10].

	Gas/fossil = 0.32		Gas/fossil = 0.25		Gas/fossil = 0.4	
	2020 old	2020 new	2020 old	2020 new	2020 old	2020 new
Hardcoal						
Gross power generation %	19.5	3.9	19.5	10.9	19.5	0
gCO ₂ /kWh	790	702	790	702	790	702
Lignite						
Gross power generation %	21	21	21	21	21	16.9
gCO ₂ /kWh	976	870	976	870	976	870
Natural gas						
Gross power generation %	8.2	23.8	8.2	16.8	8.2	31.8
gCO ₂ /kWh	380	328	380	328	380	328
Mineral oil						
Gross power generation %	1.3	1.3	1.3	1.3	1.3	1.3
gCO ₂ /kWh	833	789	833	789	833	789
Total fossil						
Gross power generation %	50	50	50	50	50	50
gCO ₂ /kWh β calculated:	802	597	802	649	802	523
Mean value β:	699.5		725.5		662.5	
Factors 2003 to 2020 Compared with 858.2 gCO ₂ /kWh	0.815		0.846		0.772	
Factors beyond the trend factor of 0.8794:	0.927		0.962		0.878	

Table 3-3: CO₂ reduction factors resulting from shifting the energy source mix to a higher share of natural gas

It is assumed that the expansion of natural gas input will primarily affect the use of hardcoal. Cheap lignite has a firm place in the German base-load supply, while hardcoal like natural gas is deployed in the medium load range and helps to even out the fluctuations in power consumption and the availability of wind power. Table 3-3 is based on these assumptions.

If the supply share provided by natural gas increases to 32%, i.e. almost double, to the detriment of hardcoal, the CO₂ emissions from the electricity sector in 2020 would be 18.5% lower than in 2003. The expansion of the supply share of natural gas would therefore yield an additional 6.8 percentage points. Table 3-3 also shows the values for any bandwidth of the

share of natural gas from 25% to 40%, which would result in a reduction of CO₂ emissions in 2020 ranging from 15.4% to 22.8%.

Using the figures from the tables, the emissions can be determined for differing assumptions for an expansion or restriction of fossil power generation as well as for the effect of shifts in the relative input volumes of fossil fuels.

4. Summary of the trend-changing factors

Line	Special measures	Factor
1	Technical innovation and increase in gas share 1992-2003 (11 years)	0.920
2	At the same rate of innovation and same rate of increase in the gas share in the 17 years from 2003 to 2020 (extrapolated trend)	0.879
3	Achievable 2003-2020 by replacing half the power plant stock and constant gas share for 2003 (16.4%)	0.883
4	Achievable 2003-2020 by replacing half the power plant and an increase in the gas share towards gas/fossil = 0.32	0.815
5	Variation: gas/fossil = (0.25; 0.40)	(0.846; 0.772)
6	Trend-changing factors (measures going beyond the trend) for 2003 to 2020	1.005
7	Line 3 divided by line 2	0.927
8	Line 5 divided by line 2	(0.962; 0.878)

Table 3-4: Improvement factors for CO₂ efficiency

In the coming decades, fossil-fired power plants will continue to play a central role in Germany's electricity supply. By 2020 a large part of the power plant capacity will have to be replaced for reasons of age. Thanks to major advances in power plant technology which will continue in future, the new plants will achieve much higher efficiencies, resulting in lower specific fuel consumption and specific CO₂ emissions.

Nevertheless, the expected reduction in CO₂ emissions is often overestimated by the general public. If the present fuel mix is retained, it will be possible only to just continue the reduction trend of the past eleven years, and even that will require the rapid implementation of an expensive power plant renewal programme. Any further decreases can only be achieved if in future less coal and more natural gas is used.

In the final analysis, however, the decisive factor is the total volume of fossil fuels used to generate power. An expansion of fossil power generation, e.g. in order to reduce nuclear, would per force lead to higher CO₂ emissions.

Notes and references:

- [1] Arbeitsgemeinschaft Energiebilanzen, 01/2005; www.ag-energiebilanzen.de
The primary energy consumption of renewables is calculated according to the efficiency method. This results in lower values than with the substitution method applied formerly.
- [2] Arbeitsgemeinschaft Energiebilanzen 09/2004; www.ag-energiebilanzen.de
- [3] Arbeitsgemeinschaft Energiebilanzen 10/2004; www.ag-energiebilanzen.de
- [4] Table *Gross power generation in Germany from 1990 to 2004 by energy source*, DIW Berlin 2005
www.ag-energiebilanzen.de
- [5] J.Engelhard/RWE Power AG, *CO₂-Ausstoß senken, Anlagen schützen – die doppelte Herausforderung für Energieversorger*. Topical Conference at GSF Research Centre in Munich, 16.02.05
- [6] *Forschungs- und Entwicklungskonzept für emissionsarme fossil befeuerte Kraftwerke*. Report by the COORETEC work groups. BMWa Documentation No. 527, December 2003 (long version, p. 12)
<http://www.bmw.bund.de/BMWi/Navigation/Service/bestellservice,did=28466.html>
- [7] I. Pyc, P. Klüsener/Siemens Power Generation: *Moderne fossil befeuerte Kraftwerke*. VDE-Kongress, Berlin 2004
www.vde-verlag.de/Buecher/ivz/ivz3-8007-2827-3.pdf
- [8] Own calculations from listings of the power plant stock
- [9] *Statistik der Energiewirtschaft*, 2005 Edition. VIK Verband der Industriellen Energie-und Kraftwirtschaft e.V., Essen 2005
- [10] The share of natural gas in fossil-generated power must not be confused with the ratio of installed output. This is much higher as the gas-fired power plants only run for part of the year. In 2003, for instance, the ratio of installed output was 0.25 compared with 0.16 as the ratio of power generated.

4 Photovoltaics

1. Introduction

Among all the sources of renewable energy, solar cells, which can convert the radiated sunlight directly into electrical energy, are the most well known and most popular. Like no other technology, the simplicity of the concept and the flexible, clean modular design represent a new world of onsite power supply as the opposite pole to the dirty large-capacity coal-fired power plants with their high-voltage transmission lines and smoking chimneys. Pollution of the atmosphere there – clean air here. Photovoltaics could be the energy of the future, the antidote to climate change par excellence, if it were not for two negative factors: the installation cost and the storage problem.

If a battery existed which, for the price of a car battery, offered 30 times the energy storage capacity it would be possible to make every house self-sufficient in energy using solar cells. As it is, however, electricity is needed from the dirty power plants whenever the sun is not shining. A decentralised photovoltaic power supply will not be achievable until the storage problem is solved – and there is no sign of that happening.

2. Costs and cost reduction potential

In Germany, a 5-kW installation currently costs about 5 to 6 euros per watt of nominal output, with the actual photocells (modules) accounting for 75% of the expense. Further information, including historical details, can be found at [1]. This means that a kilowatt hour costs between €0.4 and €0.6, depending on the commercial conditions. This is 2 to 4 times the price of German domestic electricity (retail price) and 13 to 20 times the present wholesale price of €0.03/kWh. One reason for the high price of photovoltaic electricity is the lack of sunshine in Germany. A 1-kW installation generates an annual yield of 800 – 900 kWh only [1a].

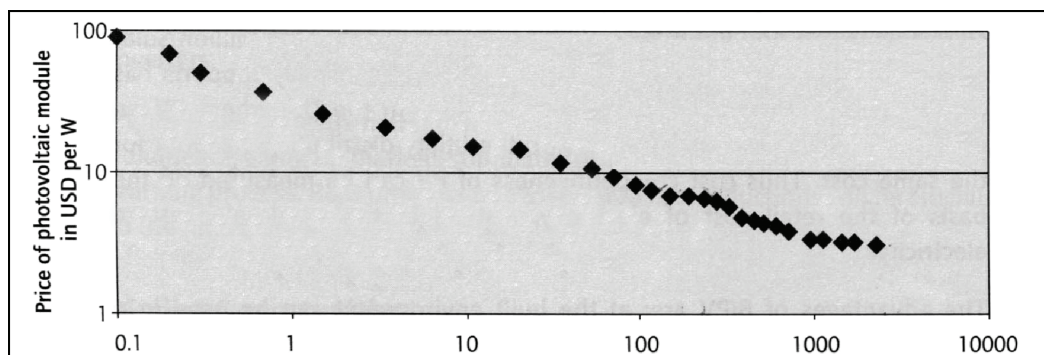

Fig. 4-1: Empirical correlation between the price paid for solar cells (\$/W) at a specific point in time and the worldwide total output of all solar cells sold up to then (in MW)

The other reason for the high price of solar-electric power is the elevated manufacturing cost of solar cells, but this will steadily decrease over time as the production volume increases, for

the production methods are improving and mass manufacture on the world market is driving costs down. Fig. 4-1 shows the evolution of the retail price for solar cells as a function of the worldwide total output of all solar cells sold up to then (expressed in MW nominal output) [2]. It would not appear to be beyond the realms of probability that a further tenfold increase in production volume could bring about a further cut of 50% in manufacturing costs.

3. Necessity for research and development

Whether this situation will indeed develop favourably depends, among other things, on research. Although the basic design of a solar cell is very simple, the physics inside the module is science at the leading edge. It cannot be excluded that breakthroughs will be achieved which will make it possible to drastically reduce production costs. These could include multiple-layer and nanocomposite solar cells or organic and polymer solar cells. It is impossible to predict whether any of the speculative ideas around will one day transform the technology. Without intensive research, however, we will never know.

But even the projects more closely related to practical reality hold enormous potential [3]. These include: reducing the quantity of material required by means of thinner wafers, innovative production technologies and power electronics. Research and development is needed to take such projects closer to industrial application. Leading contributions are being made in Germany, Japan and the USA.

4. The explosive growth of photovoltaics in Germany

Photovoltaic systems with a total nominal output of 794 MW had been installed in Germany by the end of 2004. The annual output fed into the grid amounted to 488 GWh [4]. The annual growth in both figures is extremely rapid, as illustrated in Figs. 4-2 and 4-3 with their logarithmic scales [4].

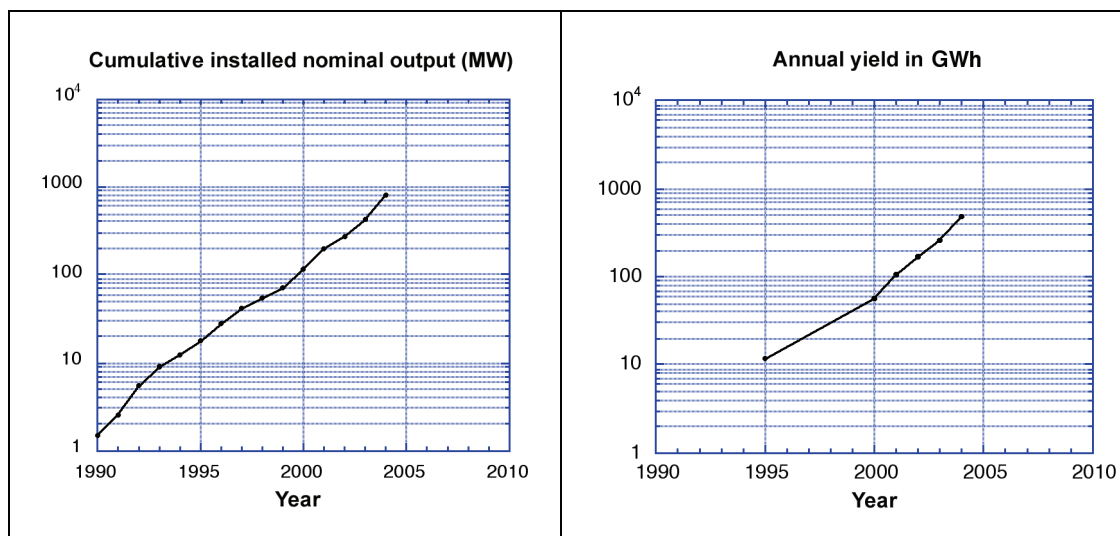

Fig. 4-2: Cumulative installed nominal output in Germany from 1990 to 2004

Fig. 4-3: Annual yields from the photovoltaic systems installed in Germany

The strong upward trend is a direct consequence of the fact that this popular technology, which holds such great symbolic importance for the energy turnaround, has received high financial support from government. The presently applicable tariffs are laid down in the Renewable Energy Sources Act (EEG) of 2004 which places an obligation on the network operator [5] to purchase at a guaranteed price. In 2006, the price is €0.518 per kWh for a medium-sized roof installation and is guaranteed for 20 years.

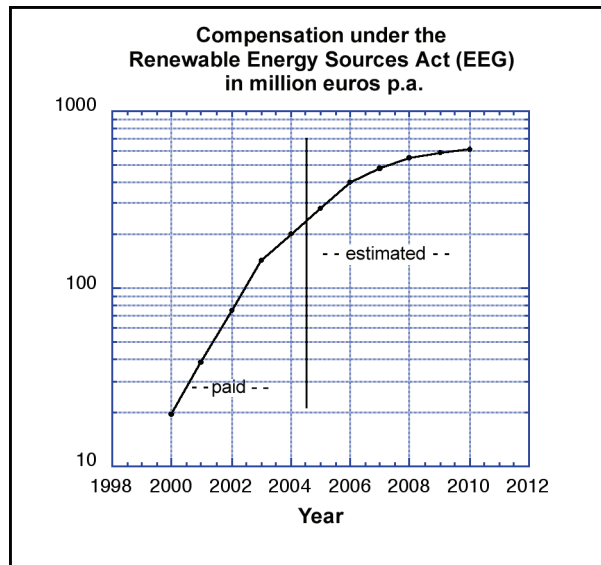

Fig. 4-4: Paid and forecast compensation for photovoltaic power in the period 2000 to 2010 according to the VdN (German Association of Electricity Network Operators)

If a new installation does not go into operation until n years after 2004, a reduced price of approx. $0.574 \cdot 0.95^n$ €/kWh applies owing to the sliding-scale reduction in compensation of 5% p.a., which means that after 10 years the amount would be approx. 0.34 €/kWh. These figures indicate that after a few years the following situation will apply: Either the prices for photovoltaic installations will have dropped sharply, in which case the guaranteed prices will still be high enough for business to continue to flourish, or the guaranteed prices will decrease more quickly than the investment cost, which will bring an end to the boom unless new government funding measures keep the industry buoyant. The amounts paid to the operators of photovoltaic installations in Germany in recent years are shown in Fig. 4-4 along with an estimate by the German Association of Electricity Network Operators (VdN) for the period up to 2010 [6]. This year the figure will be €280 million.

5. Assessment of the contribution made by photovoltaics to climate protection up to 2020

In order to assess the possible role of photovoltaics in efforts to combat climate change in the period up to 2020, it is essential to realise that the key to further expansion is the question of finance. Given this circumstance, it would not be realistic to simply extrapolate the figures shown, for example, in the curve in Fig. 4-3, for this would quickly exhaust all reasonable financial options. The estimates in Fig. 4-4 extend upwards to a funding requirement of €600

million per year, corresponding to an output of 1.3 TWh in 2010, or 0.2% of German electricity production. In the final analysis, the PV installations are still too expensive. Given that there are no foreseeable technical breakthroughs that might lead to an entirely new reference framework, the authors are of the opinion that, during the period under review, photovoltaics will not yet be able to contribute to efforts to combat climate change to any greater extent than the fluctuations in the other estimates, in particular for wind power. We therefore do not include photovoltaics separately in the figures up to 2020, which reflects the line taken in other studies [7].

Notes and references:

- [1] F. Staiß, Jahrbuch Erneuerbare Energien 02/03, Hrsg. Stiftung Energieforschung Baden-Württemberg, Bieberstein-Verlag, Radebeul 2003.
- [1a] We thank M. Hundhausen who pointed out to us that in recent years the yield had an upward trend. This is due to improvements in maintainance. The sunshine in Southern Germany is better than in the North. (M. Hundhausen, Leserbrief, Physik Journal 5 (August/September 2006), p. 15
- [2] International Energy Agency, Renewables for Power Generation, S. 70
- [3] J. Luther, Fraunhofer ISE, Neue Horizonte in: Themen 2003 – Photovoltaik – Neue Horizonte, Jahrestagung des Forschungs-Verbunds Sonnenenergie, 25.-26. September 2003, Berlin, hrsg. von G. Stadermann, FVS, Berlin 2004
- [4] www.bsi-solar.de/marktdaten.asp –
This data from the BSi was supplemented for the year 1995 in Fig. 4-3 by [1], pp. II, 86.
(At the time of the English translation, more complete data in
<http://www.erneuerbare-energien.de/inhalt/36646.php>
of the Bundesministerium für Umwelt, Naturschutz und Reaktorsicherheit)
- [5] The network operator has to pay but can spread the cost as a levy on all customers.
- [6] www.vdn-berlin.de/eeg_mittelfristprognose.asp
- [7] Even Nitsch et al., who study the greatest-possible use of renewables do not come to a significantly different conclusion. J.Nitsch et al., (DLR, ifeu, Wuppertal Institute), Ökologisch optimierter Ausbau der Nutzung erneuerbarer Energien in Deutschland, research project funded by the German environment ministry, long version, Stuttgart, March 2004, roughly scenario basis 1, p. 183

5 Wind energy

1. Development of wind energy in Germany

As of 31 December 2004, there were [1]: 16,543 wind turbines with a rated or peak output of 16.6 GW installed in Germany. Wind energy is by far the fastest growing renewable energy resource in Germany. The construction of the necessary wind-turbine infrastructure has taken place rapidly over the last ten years. Figures 5-1 and 5-2 illustrate the rapidity with which this installed base has been built up and the annual increase in input to the national grid [2]. In 2004, the input of electrical energy to the grid reached the figure of 25 TWh (approx. 4.2% of gross power-generation in Germany), thus for the first time exceeding the energy output of hydroelectric power plants, until then the largest renewable energy resource. Hydroelectric power resources were fully developed decades ago, producing on average 23 TWh/a.

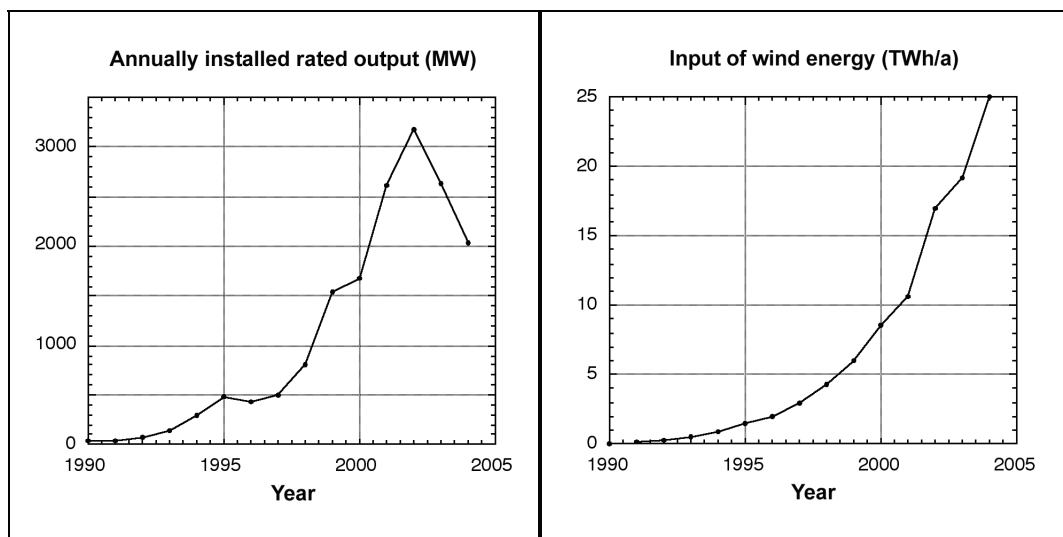

Fig. 5-1: Rated output of new installations in Germany by year from 1990 onward

Fig. 5-2: Annual input of wind energy to the German national grid from 1990 onward

The rapid expansion of wind energy is the result of a comprehensive government programme to support and open up the market. The utility companies that run the national grid are obliged by law to accept the electricity generated by the wind turbines. This energy is purchased at a fixed price per kilowatt-hour (kWh) and the costs are passed on to the end customers in their regular electricity bills. The compensation paid to the wind-turbine operators [3], a subject discussed in more detail later on in this report, is fixed at a level that has encouraged a great deal of private capital to flow into the wind-energy business. In this respect, the business structure of this segment of the power industry differs from that of the larger part of the German power industry, which is dominated by major corporations.

Sites of differing quality

The first windmills were constructed along the coast. But the best sites were soon occupied and, as more and more facilities were built, later plants had to be sited further inland, where wind speeds are generally lower. Table 5-1 below shows the typical figures (1993–2003) for the available wind power at coastal and inland sites per square meter of swept area [4], averaged over a ten-year period from

1993 to 2003. These figures reveal that the best and the worst sites differ by a factor of 2-3. As the development of wind power in Germany progressed, the quality of the occupied sites decreased from year to year, as illustrated in Fig. 5-3, which compares the proportion of increased wind-power output attributable to new wind plants in three different types of landscape.

Topography	Wind power W/m ²
Coastline, islands	171
Central highlands	103
North German plain	84
North German plain, forested	65

Table 5-1: Annual average wind power in different topographical conditions, expressed in watts per square meter swept rotor area

Roughly two thirds of the wind-power facilities in existence today were built after 1999, and only one tenth of the capacity could be provided by coastal sites; the overwhelming majority of sites have been established in the central highlands or the North German plain. To produce the same annual yield, inland sites require a higher capital investment, because a correspondingly greater number of turbines have to be installed (in inverse proportion to the figures in Table 5-1). This circumstance represents a serious disadvantage for the German wind-power plants sited in less favourable locations, if ever they should have to compete on an open market against rival operators in other countries.

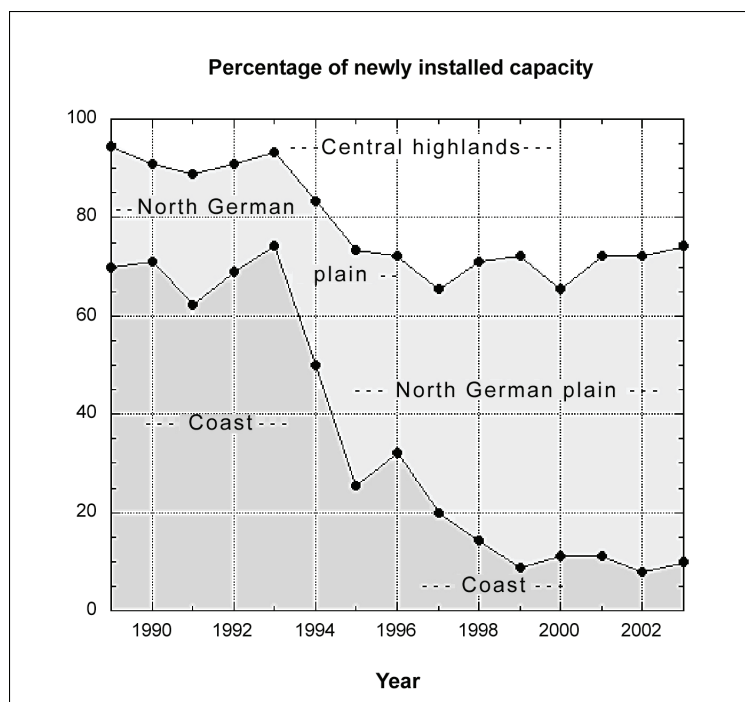

Fig. 5-3: Time distribution of added capacity by topographical category: coast, central highlands, North German plain [5]

Dividing the annual energy production (in MWh) of a wind plant by its rated output (in MW) produces a unit of time, the “peak-load hour” for the year. It represents the length of time for which a power plant would have to operate uninterrupted at full rated output in order to produce the desired annual yield. This figure is used to measure the capacity utilisation of the power plant.

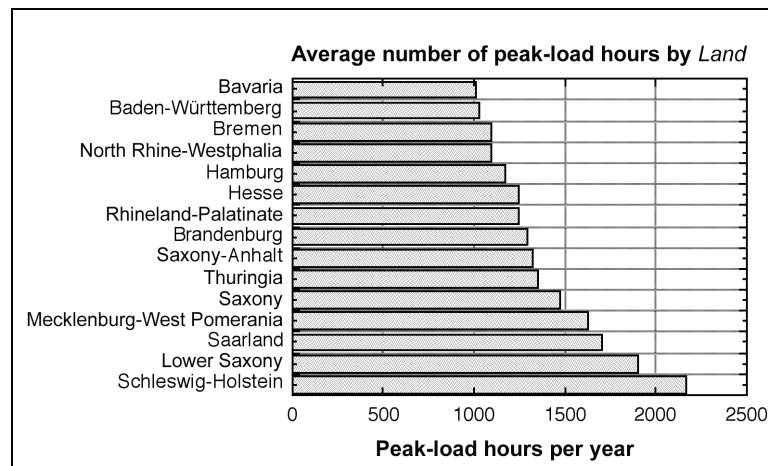

Fig. 5-4: Average peak-load hours by Land; WMEP programme of measurements by ISET 1992 to 2003 [6]

The variability of capacity utilisation at different sites is illustrated once again by the graph in Fig. 5-4. Operating a windmill in the south of Germany is on average less than half as cost-effective as in the coastal regions, on account of the natural geography. The effective mean value in Germany, averaged over the past 5 years, lies at around 1600 peak-load hours/year, fluctuating by $\pm 10\text{-}15\%$, with a slightly falling tendency as a result of the fact that new facilities tend to be installed on poorer-quality sites.

Technological evolution

It has taken two decades of unceasing engineering effort to progress from the relatively small wind turbines of the 1980s to today's multi-megawatt wind farms. Table 5-2 gives an indication of the scale of this development.

Year	D (m)	H (m)	P (kW)
1983	15	25	55
1987	20	30	75
1992	30	40	300
1996	45	60	600
2002	80	100	2500
2004	120	120	4500

Table 5-2: Evolution in the size of wind turbines: Rotor diameter D, hub height H and rated output P of models introduced in the last 20 years

But have the plants become any cheaper as a consequence? A 2-megawatt wind-energy plant today costs around €1000 per kW rated output. If you study the progression in the price of wind turbines over the years, relative to their actual output in kilowatt-hours, there is hardly any decrease [7] to be discerned. This can be partly attributed to the superimposed effect of building facilities in progressively poorer-quality locations. The figures published by the ISET institute have been adjusted to take account of this effect, by weighting the costs of newly installed plants relative to a reference site. By plotting these normalised kWh prices against the total rated generating capacity installed up to the year in question, in a graph based on a double logarithmic scale [8], it is possible to depict the "learning curve", see Fig. 5-5.

The downward trend visible in the resulting curve can be interpreted as representing the learning effect derived from the increasing mass production. Illustrated this way, the data clearly indicate two distinct phases: There is a relatively swift drop in costs for the first 1000 MW of installed capacity, with the normalised price of electricity production relative to the reference site falling by factor of 0.5 up to this point, but the change registered for the last 90% of installed rated capacity is only by a factor of 0.9.

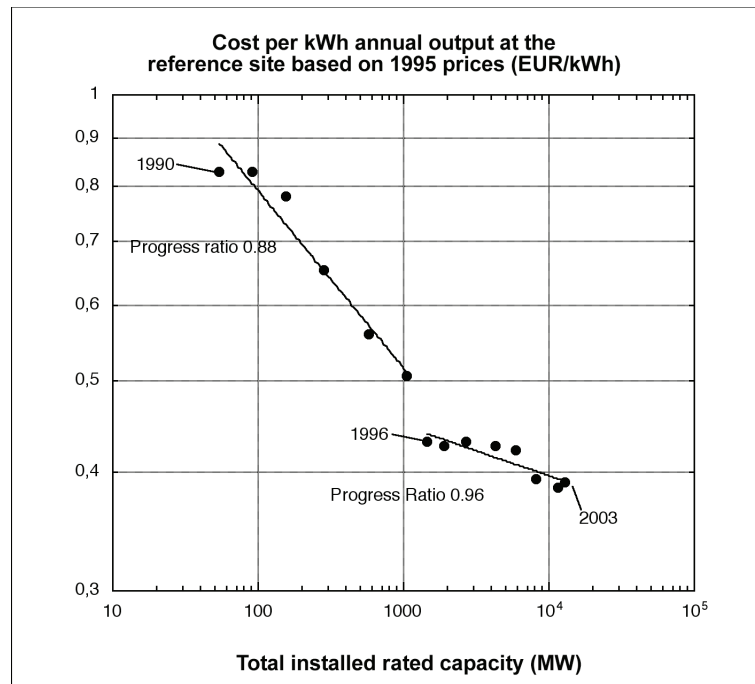

Fig. 5-5: Cost of new windmills (divided by the calculated annual output in kWh at the reference site) plotted against the total installed rated capacity in Germany. The “progress ratios” indicate the factor by which the cost is reduced each time the installed rated capacity doubles.

It is instructive to study the case of the GROWIAN giant experimental wind turbine, which was constructed in 1983 and demolished in 1988. It had a rotor diameter of 100 m and a hub standing at the same distance above the ground, but the project was beset by problems of material fatigue and structural durability, and was abandoned. Technical advances take time to achieve, and it was overly optimistic to expect to master such sophisticated technology in so short a time. The same will apply to the next generation of wind turbines, which it is planned to construct offshore on foundations at a depth of 40 m under the sea (see further on). They, too, will require a certain time to grow to technological maturity.

Capacity credit

The principle of offering public subsidies to prime the market for wind energy has already been mentioned. Without entering into a detailed analysis of the price structures that have been fixed for a period of 20 years [3], we would nevertheless like to make reference to a set of statistics [9] that include data describing the effective payments for energy fed into the national grid (per kWh), averaged over the period for which the compensation is paid. Because capacity credit is paid on a sliding scale, diminishing at a rate of 2% p.a., and owing to the amendment of the Renewable Energy Sources Act (EEG), these payments are dependent on the date of entry into service and also annual

output, the latter as a consequence of supplementary grants for the development of facilities at poorer-quality sites (Table 5-3).

Site quality rating	Entry into service	Transfer to lower tariff	Average compensation
75%	January 2001	January 2021	9.1
100%	January 2001	March 2017	8.54
125%	January 2001	July 2011	7.72
150%	January 2001	January 2006	6.92
75%	January 2005	January 2025	8.53
100%	January 2005	March 2021	7.93
125%	January 2005	August 2015	7.05
150%	January 2005	January 2010	6.18

Table 5-3: Typical capacity credit in c€/kWh for new installations, as foreseen by the Renewable Energy Sources Act (EEG) [9]

2. Development of wind energy, mainly offshore

The construction of offshore wind farms in the North and Baltic Seas is a logical step towards the creation of more profitable wind-energy sites for Germany. The prospects for achieving very high yields are excellent, with an estimated average potential of 3500 full-load hours p.a. in the German Exclusive Economic Zone, more than twice as high as the yield that can be achieved on land. But it must be taken into consideration that the technical challenge of laying foundations on the sea-bed and the effort needed to deal with problems of maintenance and corrosion will be that much higher. Denmark, Sweden, the UK and the Netherlands already have such experience. By the end of 2003, these countries had realised projects involving nearly 300 offshore wind turbines with a total rated output of 533 MW, but largely at depths rarely exceeding 12 m, apart from certain recent cases at 18 and 25 m respectively [10]. Consortiums have formed in Germany and, up to mid-2004, submitted applications with the German authorities for permits to build facilities producing a total rated output of 41 GW [11]. This is far more than the output for which the German authorities were planning to issue permits.

But it is important to realise that the situation in Germany is complicated by the fact that it is a country in which a high priority is accorded to matters concerning the conservation of nature. An added difficulty is the public opinion that offshore wind turbines should preferably not be visible from the land, forcing operators to construct their facilities far out at sea. The German government has identified a certain number of non-controversial sites that might be considered suitable for wind farms [12]. *“Bearing in mind that offshore installations for the harvesting of wind energy represent an extensive, long-term disruption of the marine environment, and that we have little empirical data on which to base predictions of the impact of offshore wind farms on the ecosystem, we prefer to adopt a precautionary stance and take a step-by-step approach to such plans. Each succeeding stage in the process will be dependent on a well-founded, positive assessment of the environmental impact and the preservation of natural habitats. Following these principles, it ought to be possible to build up an additional capacity of between 20,000 and 25,000 MW between now and 2030,”* states Frau Viertel of the German environment ministry [13].

Our analysis is based on the infrastructure development plans drawn up by the German government [12] and, for specific details, on the scenario recently published in a study compiled by the German Energy Agency dena [14], see Table 5-4. This study predicts that by 2020 there could be offshore wind farms in operation generating a peak output of 20.4 GW and land-based wind farms with an output of 27.8 GW, making a total of 48.2 GW.

Year	Onshore	Repowering	Offshore	Total
2007	21,2	0,5	0,7	22,4
2010	23,2	1,1	5,4	29,8
2015	24,4	1,8	9,8	36,0
2020	24,4	3,5	20,4	48,2

Table 5-4: Predicted expansion of wind energy according to the scenario envisaged by the dena Project Steering Group (available peak output in GW) [15]

For the reasons explained in the Annex to this chapter, the timetable on which the figures in Table 5-4 are based must nevertheless be regarded as totally unrealistic. For our own calculations in this report, we have assumed that the wind-power capacity planned for 2015 will not actually be available before 2020, and consequently that the installed base in 2020 will not exceed a rated output of 36 GW.

To estimate the amount of electrical energy that this installed base would be able to produce, we based our calculations on 1600 peak-load hours from onshore sites and 3500 from offshore sites [16]. The annual output of electrical energy produced by wind power in 2020 would then amount to approximately 76 TWh, or about 14% of the projected net electricity consumption in Germany for that year.

With regard to the prospect of a future deregulated market for electricity, including that produced by wind plants, it should be noted that certain EU countries possess some very high-yielding wind-energy sites on top of the cliffs of the Atlantic coast, which are easily as productive as those that Germany plans to install out at sea, but which do not suffer from many of the problems facing offshore wind farms; see map and table overleaf, especially columns 4 and 5. For instance, wind plants operating for 4150 peak-load hours per year [17] can be found on hilltops in the Orkney Islands, where average wind speeds reach 10-11 m/s.

Use of conventional generating plant to supplement wind power, and expansion of the national grid

Owing to the inconstant nature of the wind, which cannot be relied on to produce enough electricity to meet demand at every instant, it is obvious that wind plants have to be planned from the outset in conjunction with the appropriately dimensioned conventional power generation facilities. This backup capacity must be able to be switched online in the absence of wind or when wind-plant output falls below the maximum level. A distinction must be made between this backup capacity and the availability of an auxiliary “balancing capacity”, that serves the purpose of rapidly compensating for fluctuations in wind speed in the event that these should not correspond to those predicted on a quarter-hourly basis. In view of the fact that the power utilities have a legal obligation to give priority to wind energy when it is fed into the grid (which consequently does not form part of the reserve), the balancing capacity must be provided by conventional means. The required capacity in both cases with respect to the development of wind energy in Germany was investigated in detail in the dena grid study [14]. The maximum positive reserve capacity in a configuration of around 36 GW was estimated

at 7 GW (19.7%), and the negative reserve capacity at 5.5 GW (15%). These rapidly switchable reserves need to be held in readiness at all times, because there is no way of knowing when the maximum supply might be needed. The first of the two above-mentioned reserves – that for the absence of wind – has been specified as corresponding to 94% of the installed wind capacity in the final configuration. In other words, the development of wind energy will not reduce the capital costs of conventional power-generation plants, but simply enable them to economise on the cost of fuel – and generate electricity without releasing CO₂ as a by-product.

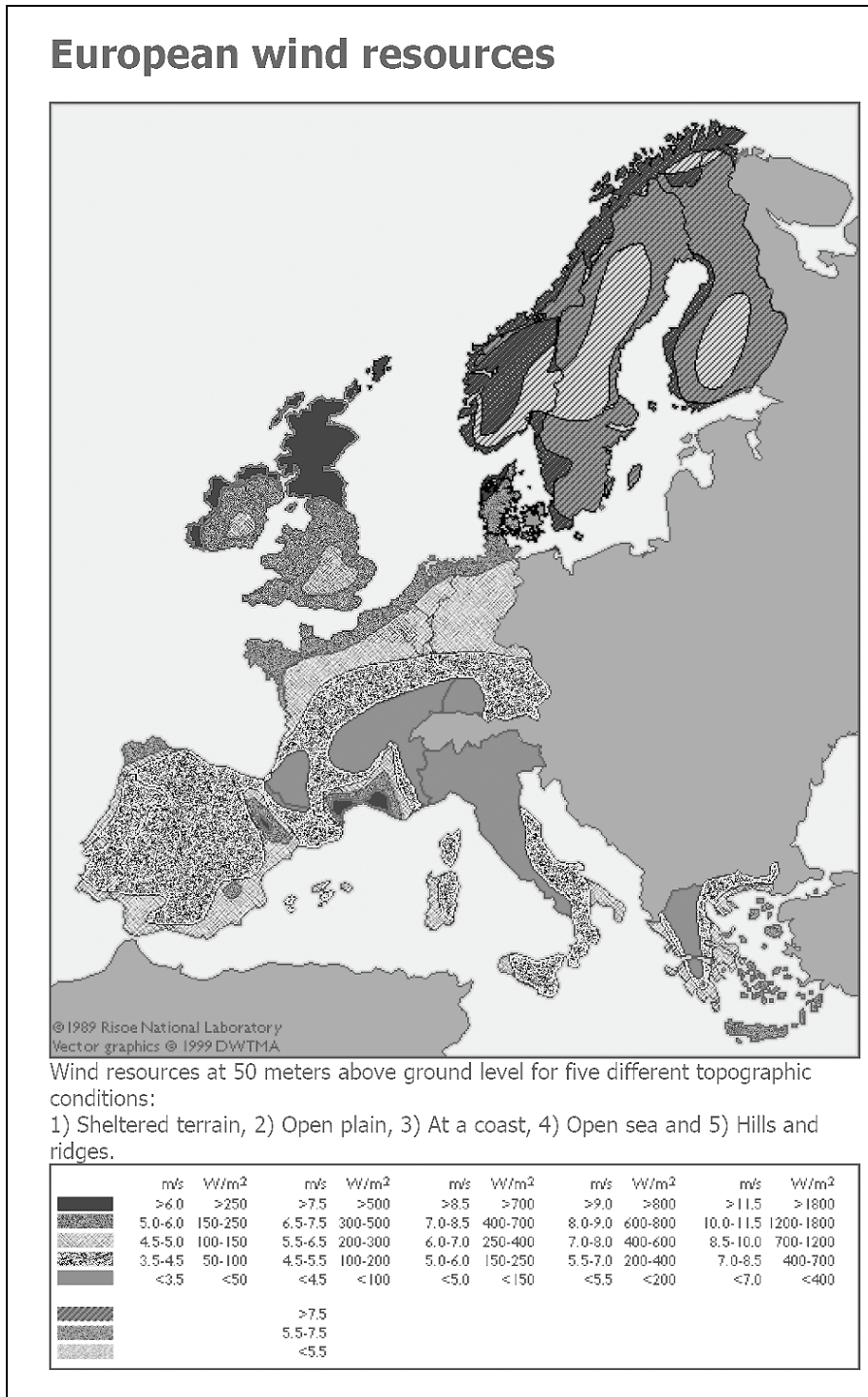

Fig. 5-6 Wind resources in the European nations

When wind turbines are installed offshore, the electricity they produce has to be transported to land using submarine cables and then distributed to the consumer stations over the high-voltage power network. The present networks are designed to distribute electricity from the production centres outwards across the country. In terms of structure, and also in terms of transmission capacity, they are not yet equipped to deal with this new function. This was one of the aspects that was investigated in detail in the dena grid study, which came to the conclusion that several hundred kilometres of new high-voltage power lines would have to be constructed to transport the envisaged additional wind power. More precisely [18], 8 new sections of new 380-kV power lines extending over a total distance of 850 km will be needed to cover the construction phase up to 36 GW, of which 6 sections will already be needed in the preceding phase for an output of up to 29.8 GW (see Table 5-4).

It should be noted that this introduces a serious obstacle into the plans to meet objectives for cleaner forms of energy production. It is a well-known fact that it can take many years to obtain the necessary approvals for the construction of new high-voltage power lines, without any up-front assurance that these approvals will actually be granted [19]. It is debatable whether the present legal basis for such decisions is appropriate to the projects at stake. And yet the regulatory framework is the essential starting point for the government's policy of promoting the development of offshore wind energy. An insistence on laying underground cables rather than installing overhead power lines in the high-voltage distribution network, for purely aesthetic reasons, increases investment costs by a factor of six to eight [20].

Expansion of the transmission network, the need to provide backup capacity using conventional power stations, and reactive power consumption represent a sizeable additional burden on the cost of electricity from wind. However, the present study is not intended as an economic analysis. Interested readers are referred to the dena grid study, which presents a more detailed analysis of these issues.

3. Summary of the share of wind energy in the Germany power-generation system

A summary of the share of wind energy in the production of CO₂-free electricity can be found in Table 5-5, which gives the present figures and those projected for 2020. As in Table 5-4 above, and as explained in the Annex, these figures are based on an additional capacity of 36 GW rated output to be provided by 2020, 9.8 GW by offshore facilities and 26.2 GW onshore.

Electricity production 2004	25 TWh
Average growth over the last 10 years	2.3 TWh/a
Estimated electricity production 2020	76 TWh

Table 5-5: Summary of present and future share of wind energy in electricity production

Annex:

Critical assessment of development plans up to 2020 as seen by the dena grid study

It is not very likely that wind power will be developed between now and 2020 to the extent envisaged in Table 5-4. For one thing, there is no assurance that the offshore wind-power industry will be able to obtain the requisite level of compensation. The payment scheme offered under the terms of the 2004 Renewable Energy Sources Act (EEG-2004) envisages capacity credits to be borne by the end consumer [21] based on a basic tariff of 5.7 cents per kWh, supplemented by a payment for plants taken into service prior to 2011, of 9.1 cents per kWh in total, granted for an initial period of 12 years. To this must be added a sliding-scale scheme of 2% p.a. for new installations from 2008 onwards. The government policy for the development of offshore wind power imposes conditions relating to economic viability [12, 22], which gives it the justification for reducing guaranteed prices after 31 December 2010. The peak output of 15 GW which the dena grid study expects to be supplied by offshore plants constructed between 2010 and 2020 would theoretically result in an annual electricity production of 52 TWh. But at the present time there is no way of knowing whether it will be economically viable to produce these 52 TWh p.a. for 4.5 to 5.4 cents per kWh [23], and whether it will be possible to sell offshore wind power at market-compatible prices. Even the dena grid study expresses doubts in this respect.

A secondary problem concerning the funding of wind energy projects is that in the ultimate configuration, according to the dena grid study, more wind power will be installed and need to be fed into the grid than is required to cover demand in off-peak periods when high wind speeds are available. For this reason, the plans make provision for exporting excess electricity [24]. But it is anyone's guess whether it will be possible to offer this electricity at such low prices that it can be exported abroad. It is reasonable to suppose that a policy of export subsidies financed by the taxpayer's money or hikes in electricity charges will not be regarded as acceptable or even be envisaged.

The question of whether potential operators will be willing to make capital investments of €40 billion [25] in offshore wind energy over the next fifteen years depends on the one hand on the technological evolution of offshore wind turbines and the experience to be gained through their operation – and that's an unknown quantity, given that as of the present date no single wind park has ever been built to operate under the difficult conditions that prevail off the German coast, which are aggravated by the depth below sea level and distance from the coast. On the other hand, the evolution in the cost of electricity produced from competing fuel sources, and in the cost of electricity imports, cannot be predicted either. The length of time it will take to amortise offshore investments is heavily dependent on the availability of clear answers to these questions.

In any case, the systematic discrepancy between the two as-yet competing methods of state subsidies for CO₂ reduction will almost certainly be called into question. Firstly, there is the minimum price scheme that offers a fixed tariff in return for the obligation to accept feed-in, financed by the end consumer [21] (EEG), and secondly there is the method of issuing CO₂ emission certificates, which can be issued by the authorities up to a certain limit, and are thereafter tradable. From the point of view of the national economy, these two methods are mutually incompatible [26] and will need to be

resolved on a European scale. It would therefore be unrealistic to expect that the practice started under the 2004 amendment to the EEG will continue along the same lines.

Moreover, there is too much confusion concerning the time scale for the implementation of the offshore wind projects. The dena grid study discusses a number of difficulties that will have to be faced by these large-scale industrial projects – ranging from the willingness of banks to finance these projects (each one costing several hundreds of million euros), and the willingness of insurance companies to cover the risks involved, through to the extremely time-consuming administrative procedures for planning and approvals. The latter applies most particularly to the high-voltage power lines needed to connect the offshore plants to the grid. The increasing input of fluctuating wind power also presents problems concerning the dynamics of load stabilisation, which with today's technology would lead to brownouts (even extending over the German border into neighbouring countries). Possible solutions appear to exist, but they first need to be studied and then implemented. – Even the authors of the dena grid study foresee a slower-than-planned development of offshore capacity. This is understandable, for it involves venturing into uncharted territory, in which several generations of prototypes will have to be tested before the technology slowly but surely reaches commercial maturity. One day, this highly promising technology will hopefully be accorded its turn, but the timetable proposed in the dena grid study for the period up to 2020 appears totally unrealistic.

If at all growth in German wind energy resources ever takes place to this extent, it will certainly be spread over a relatively long stretch of time and operate with a different financial model. In view of the existing difficulties, we think it more likely that the level of capacity labelled “2015” in the dena grid study will not be able to be reached before 2020. Consequently, a wind-energy share of 76 TWh/a cannot be reckoned with before 2020 [27].

Notes and references:

- [1] DEWI, German Wind Energy Institute, Wilhelmshaven
<http://www.wind-energie.de/informationen/zahlen-zur-windenergie/>
- [2] *Windenergiereport Deutschland 2004*, published by ISET (Institut für Solare Energieversorgungstechnik), Kassel, pp. 21, 47. These figures were modified for 2004, taking into account (a) the more recent data from VDEW (there is a slight discrepancy between the two survey methods, but which generally lies below 2%) and (b) those from DEWI [606].
- [3] An overview of tariff structures and other subsidies is provided in F.Staiß, Yearbook *Erneuerbare Energien* 02/03, published by Stiftung Energieforschung Baden-Württemberg, Bieberstein Fachbuchverlag, Radebeul 2003 (regular editions are planned). The best source for the latest tariffs is the text of the Renewable Energy Sources Act 2004.
- [4] ISET, *Windenergiereport Deutschland 2004*, p. 37; the figures are based on measurements at a height of 10 m above the ground, used to determine annual average wind power.
- [5] ISET, *Windenergiereport Deutschland 2004*, p. 24
- [6] *Ibid.*, p. 52
- [7] *Ibid.*, p. 82
- [8] *Ibid.*, p. 83
- [9] *Ibid.*, p. 89
- [10] Ref. [14], Tab. 5
- [11] *Ibid.*, Tab. 7

- [12] *Strategie der Bundesregierung zur Windenergienutzung auf See*, working paper drawn up by five government departments and dena, under supervision of the environment ministry, January 2002
- [13] C. Viertl, Federal Ministry for the Environment, Nature Conservation and Nuclear Safety, in a lecture entitled *Windenergie: Entwicklung Onshore und Offshore* at the Physikertagung München 2004. M. Keilhacker editor, *Perspektiven für die Energie der Zukunft*, Bad Honnef 2004.
- [14] dena grid study: *Integration into the National Grid of Onshore and Offshore Wind Energy Generated in Germany by the Year 2020*, study compiled on behalf of the German Energy Agency dena by a consortium consisting of DEWI, EON Netz, EWI, RWE Transportnetz Strom und VE Transmission, final report, Cologne, February 2005
- [14a] The guaranteed capacity of conventional power stations amounts to roughly 93% of the planned available power (at a level of 99% availability). In the planned wind-energy scenario for 2015, the corresponding figure lies at only 6% of rated output (dena grid study, chapter 12.3)
- [15] *Ibid.*, Table 2-3
- [16] The figure of 1600 h/a represents the yield achieved over the last 5 years by onshore plants. The figure of 3500 h/a is an estimate by ISET, which was also used in the dena grid study.
- [17] www.oref.co.uk/orkney-energy-audit.htm
- [18] dena grid study, Figs. 4 and 6
- [19] Communicated verbally by M. Boxberger, Eon-Netz, in his lecture to the energy working group of the Deutsche Physikalische Gesellschaft, Bad Honnef, 27 April 2005, *Aktuelle Aspekte und Perspektiven der Windstrom-Integration im Übertragungsnetz* (1 project 80 km 380 kV had to be abandoned after 10 years, 1 project 9 km 110 kV has been in dispute for 10 years, 50 km 380 kV (wind-related) awaiting decision for 2 years, 120 km 110 kV (also wind-related) awaiting decision for 3 years).
- [20] Communicated verbally by H. Brakelmann, Duisburg, in his lecture entitled *Freileitungen und Kabel zur Hochspannungsübertragung*, to the energy working group of the Deutsche Physikalische Gesellschaft, Bad Honnef, 28 April 2005.
- [21] The grid operator pays initially, but has the right to recoup these expenses from the end consumer in the regular electricity bill.
- [22] *Nachhaltigkeitsstrategie 2002: Perspektiven für Deutschland – Unsere Strategie für eine nachhaltige Entwicklung*, published by the Presse- und Informationsamt der Bundesregierung, Berlin April 2002.
- [23] The guaranteed kWh price depends on the year in which the wind plant was taken into service, owing to the sliding-scale tariff (2% p.a.). The price for 2011 is set at 5.4 cents, and for 2020 at 4.5 cents.
- [24] dena grid study, Part 2, Section 3.
- [25] Estimated figure 2 k€/kW rated output; 20 GW in Tab. 5-4, line '2020'.
- [26] Federal Ministry of Economics and Labour (BMWA) scientific council (Chr. v. Weizsäcker in charge), expertise on grants for renewable energies, dated 16 January 2004. This expertise justifies the opinion that the Renewable Energy Sources Act (EEG) will become obsolete and too expensive to implement once trading in emission certificates becomes fully operative, and thus ought to be repealed.
- [27] Table 5-4: $(24.4 + 1.8) \text{ GW} \cdot 1600 \text{ h/a} + 9.8 \text{ GW} \cdot 3500 \text{ h/a} = 76,200 \text{ GWh/a}$

6 Biomass

1. What is biomass?

Basically any recent organic matter can be used to produce energy from biomass, including dead but not yet fossilised phytomass and zoomass, as well as organic waste matter such as paper, cellulose or the organic household waste fraction. The Biomass Ordinance (BiomasseV) provides the relevant legal definition. Unlike fossil fuels, biomass energy sources are still actively involved in the carbon cycle, so burning biomass generates **no additional** CO₂: the process of natural decay and decomposition, which might take years or even decades, is simply accelerated using technology and completed without generating CH₄ as an intermediate product. Hence the use of bioenergy sources does not increase CO₂ in the atmosphere over the medium and long term: in effect biomass energy sources are 'CO₂ neutral'.

Recently, specialised **energy crops** (wood, straw and oil-based biomass) have been reintroduced to supply energy. Energy crops are now being grown on land set aside from agricultural production in response to current food overproduction in Europe. Essentially though, the prospect of foodstuffs and energy crops competing for space cannot be ruled out over the long term. It is perhaps worth remembering here that curbs on growing energy crops were only put in place in Germany as late as the 20th century. Agricultural production of biomass to generate fuel stretches back a long way: where we used to have oats for horses, we now find rape for engines.

2. Current energy use of biomass

Energy consumption for a large part of the population in developing countries and even in countries such as India or China is based largely on the use of biomass (Fig. 6-1). According to an IEA estimate, 2.4 billion people use traditional biomass for cooking and heating.

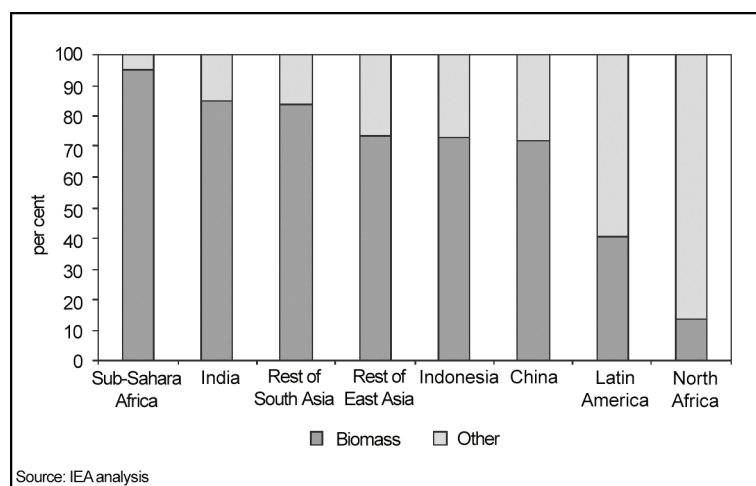

Fig. 6-1: Proportion of traditional biomass used for residential energy consumption [1]

But equally in some modern industrialised countries, biomass still or once again accounts for a sizeable chunk of primary energy (PE) usage, as Fig. 6-2 illustrates with EU Member States used by way of example. Biomass accounts for the largest share of renewable energy in terms of overall usage in most EU countries, easily exceeding hydropower. (It should be remembered, however, that the standard 'efficiency method' in use since 1995 for PE statistics means electricity generated from hydropower is converted virtually 1:1 into 'primary energy').

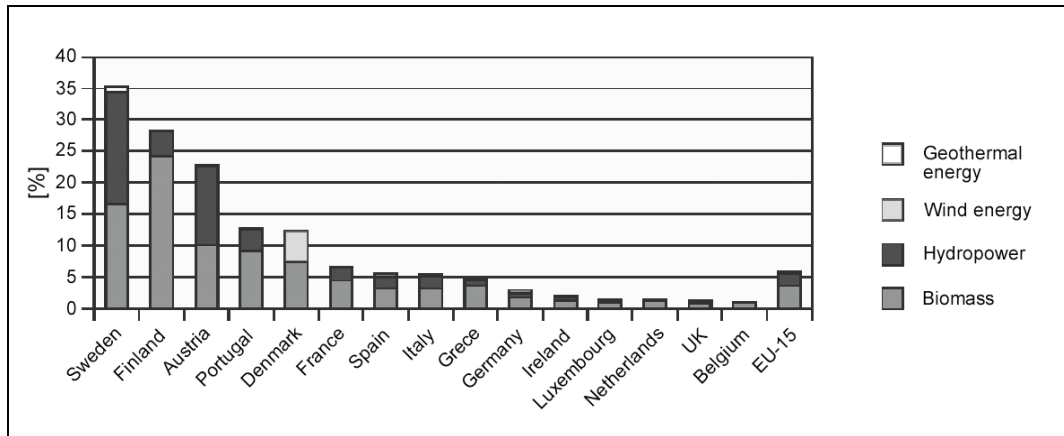

Fig. 6-2: Proportion of renewables in relation to primary energy consumption in the EU in 2002 [2]

Biomass accounts for more than 10% of PE usage in three EU countries and rises to as much as 24% in Finland.

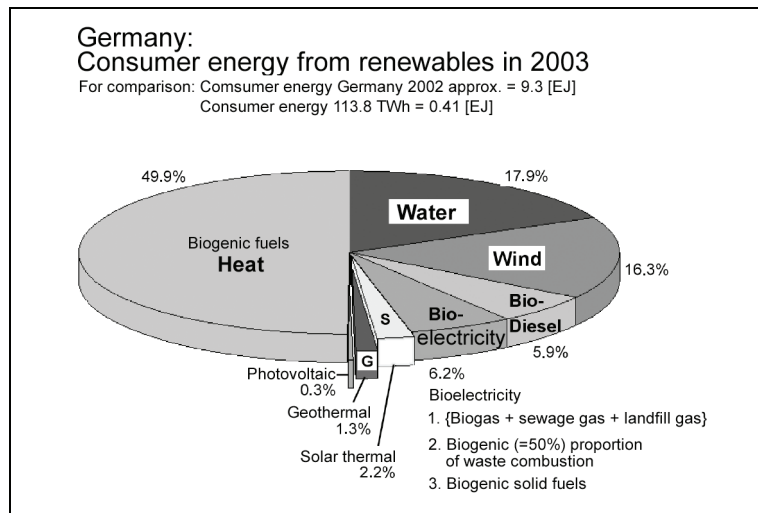

Fig. 6-3: Final energy from renewables in the Federal Republic of Germany 2003 (equivalent of 4.4% of the total final energy). Almost 2/3 of renewable energy comes from biomass [3]

In heavily populated Germany, biomass may only provide a modest 3% of PE usage but easily provides the largest contribution to renewable energy, accounting for almost 2/3 in Germany (in 2003) (Fig. 6-3). Over the past few years, the use of biomass, which is turned into power and fuel, has also gathered pace. For instance, 2% of the diesel fuel

sold as biodiesel is generated from rape. This is thanks to sustained government funding, especially including mineral oil tax relief (at present applicable until the end of 2009). Since 1.1.2004 biofuels have also been exempt from mineral oil tax where up to 5% biofuel is used as a blending component. Consequently, standard motor vehicles can now be powered with biofuels without the need for engine modifications.

In conjunction with the Biomass Ordinance, the Energy Conservation Act (EnEG) also provides massive additional funding. In this respect, power generation from renewable raw materials and from biogenic residues and waste matter is subsidised through assured, priority sales and high guaranteed payments to such an extent that, for many applications, it has crossed over into the profit zone in terms of commercial viability.

3. The diverse technical uses of biomass

The huge variety of individual energy sources classified under the collective term biomass is reflected in the equally varied range of processing options. Figure 6-4 provides an overview of the bioenergy sources used and the thermochemical, physical-chemical and biochemical processes applied to convert these into usable energy sources.

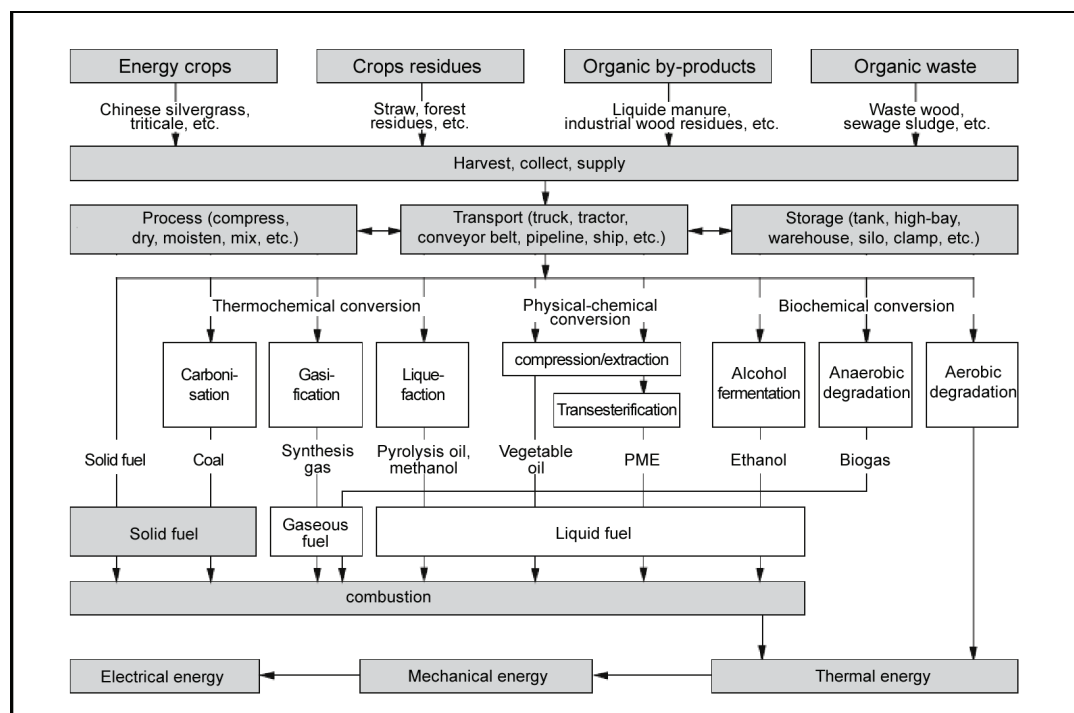

Fig. 6-4: Varied options for providing energy from biomass [4]

This study makes no attempt to look in detail at the range of options shown in Figure 6-4. It is notable that biomass can be converted efficiently into liquid fuels. Given current technology, these fuels can then be used as a direct substitute for mineral oil in the road transport sector. This has already been the case for several years and increasingly so more recently in Brazil with the use of alcohol as a fuel. Meanwhile the use of biodiesel in Germany has already moved into the percentage range.

Combining some process stages, which are already marketable or where a great deal of work is already being done to come up with optimum cost-effective engineering and organisational solutions, ultimately means biomass can provide any form of energy, be it heat, electricity or fuels. In this respect, biomass can eventually be integrated into all applications for which fossil fuel sources still currently provide the answer. Biomass can even be used in the non-energy sector as a feedstock for plastics and other carbon-based materials (keyword: 'biorefinery').

From a technical point of view, biomass can thus be seen in the long term as a universal sustainable replacement for fossil raw materials once the extensive research and development work has been completed. The question remains to what extent this can be realised on a sufficiently large scale and whether issues regarding competition faced by energy crops from other bioproducts (e.g. foodstuffs) can be resolved.

Conservation concerns also need to be addressed though: to what extent can the human race, having already devastated its fossil legacy, now start stripping the remaining energy resources bare, and how much more of the Earth's scarce biotic production area can we take for ourselves? These questions require a responsible assessment and allocation of space – also taking into account the ethical considerations associated with the concept of the 'integrity of creation'. Fortunately the BMU study "Ökologisch optimierter Ausbau der Nutzung erneuerbarer Energien in Deutschland" [10] clearly acknowledges the conservation constraints and ventures to quantify these.

The following section sets out facts relating to the availability and the technical, economic potential of biomass usage.

4. The potential of biomass usage around the globe and in Germany

Biomass is traded or even taxed only to a limited extent; there are no well-founded statistics on current consumption or available potential, added to which the relevant figures for many countries are fairly unreliable. Nonetheless, the figures do provide a survey of the global potential for biomass that can be used for energy (Table 6-1).

	Wood-based biomass	Straw-based biomass	Dung	(Alternative: biogas ^a)	Energy crops	Total
Region	[EJ/a]	[EJ/a]	[EJ/a]		[EJ/a]	[EJ/a]
Africa	5.4	0.9	1.2	0.4	13.9	21
Europe	4.0	1.6	0.7	0.3	2.6	9
Former USSR	5.4	0.7	0.3	0.1	3.6	10
North America	12.8	2.2	0.8	0.3	4.1	20
Latin America & Caribbean	5.9	1.7	1.8	0.6	12.1	22
Asia	7.7	9.9	2.7	0.9	11	21
Middle East	0.4	0.2	0.1	0.0	0.0	1
World	41.6	17.2	7.6	(2.6)	37.4	104

^a Potential for obtaining biogas from the illustrated dung potential

Table 6-1: Technical potential for solid bioenergy sources in the world, broken down by region. For comparison: World primary energy consumption in 2000: 400 EJ/a. [5]

In this respect we are guided by the interpretation in [4] and limit ourselves to dealing with the 'technical potential', i.e. the proportion of theoretically available potential that could actually be used, taking into account the given general technical requirements and insurmountable structural and ecological constraints. Here biomass is subdivided into two categories of 'Residues and by-products' and 'Energy crops' cultivated specifically for energy use. The following forms of bioenergy are involved:

(1) Residues and by-products

- a) *Wood-based residues and unharvested forest growth*: wood biomass accounts for around 40%, the largest share of the technical potential of bioenergy. The geographic focus is North America (see Table 6-1, Column 2).
- b) *Straw-based residues and by-products* mainly from agricultural production: after wood-based residues and energy crops, straw-based, mainly agricultural, residues form the third-largest individual group within bioenergy. The geographic focus is Asia (Table 6-1, Column 3).
- c) *Dung*: The assumption is that around half of the dung generated by rearing livestock could be used as a fuel in the dried state. Worldwide around 7.6 EJ/a of dung would be generated (Table 6-1, Column 4), with around 93% coming from cattle farming and approx. 7% from pig farming. Alternatively (Table 6-1, Column 5), animal excrement could also be converted into biogas through fermentation: while this would only generate energy potential of 2.6 EJ/a, the fermentation residue would provide an important soil improver.

(2) Energy crops

The available land area essentially limits the cultivation of energy crops optimised specifically for energy use. Typical estimates vary by a factor of between 2 and 3. In the industrialised nations a realistic assumption of land that can be converted for energy crops is 7% of existing arable land; Africa and Latin America offer the greatest land potential for energy crops. 37.4 EJ/a is taken as an estimate for the potential annual global harvest of energy crops, with 13.9 EJ/a coming from Africa and 12.1 EJ/a from Latin America. Overall, it is estimated that energy crops could account for around a third of the total technical potential of bioenergy (see Table 6-1, Column 6).

If we now look at the bioenergy potential shown in Table 6-1 and remember a given current world primary energy consumption of approx. 400 EJ/a, we can say the following:

- Globally the technically exploitable potential of bioenergy is around 100 EJ/a, the equivalent of around a quarter of the current global primary energy supply. As PE demand grows, so this proportion is set to fall accordingly. With the generally expected doubling of world energy demand in the future, the assumption is that bioenergy is unlikely to contribute much more than 10%.

- Unforeseen technical breakthroughs could also provoke a rise in the share of global primary energy demand supplied by biomass. For instance, improvements in production methods could lead to a sharp increase in energy crop yields. Thanks to far less stringent quality requirements placed on the use of energy crops compared with food crops, there is far greater leeway in terms of production and breeding.
- The two largest single contributors to bioenergy are wood-based residues, with a significant part coming from 'unharvested forest growth', and energy crops. As the population grows, there is likely to be competition for land use with other agrarian products and for nature conservation (preserving biodiversity) in these areas over the long term.
- Bioenergy will make a very substantial, yet clearly limited contribution to the energy supply on a global scale. As such, the key challenge will be to fully exploit the structural strengths of bioenergy both as a storable physical energy source that can be converted into virtually any form of useful energy, and as a feedstock for the chemical industry. Consequently, bioenergy should not be developed or utilised long term for applications where alternatives already exist based on fluctuating sources (such as sun and wind).

A comparison of potential and current actual usage in the individual regions around the globe shows that, apart from Asia where more biomass is already used than regenerated leading to unsustainable overexploitation, only 10 to 40% of the technical potential of bioenergy has been utilised to date. A global comparison, i.e. including Asia, shows 38% of the technical potential currently being utilised. Large reserves still lie unexploited, especially in North and South America but also in the former Soviet Union. [6]

In densely populated Germany there is still substantial technical potential for further developing bioenergy, apart from the sources already being utilised. As Table 6-2 shows, the projected total potential is around 0.75 EJ/a, the equivalent of about 5% of our current primary energy consumption. The reserves primarily relate to forestry and, perhaps somewhat surprisingly, to the cultivation of energy crops. Intensive agriculture coupled with EU integration has seen farmland set aside, which could be brought back on stream again to produce energy crops.

	Energy potential in [EJ/a]
1. Residues	
1a Forestry residues,	0.270
of which: Forest residues	0.142
Industrial wood residues	0.040
Waste wood	0.081
Other wood residues	0.007
1b Agricultural residues^a	0.104
2. Energy crops^b	0.350 - 0.400
Total	approx: 0.750

^a Only straw, ^b Average figure for a biomass mix including whole-plant cereal production (max. 0.350 EJ/a), grass production incl. Chinese silvergrass (max. 0.420 EJ/a) and short-rotation fast-growing tree varieties such as poplar (max. 0.400 EJ/a)

Table 6-2: Technical potential (EJ/a) of solid bioenergy sources in Germany, broken down by biomass fractions. For comparison: current PE consumption in Germany: approx. 14 EJ/a. [7]

Breaking the figures down into federal states reveals substantial potential for bioenergy from forestry and agricultural residues in Bavaria in particular.

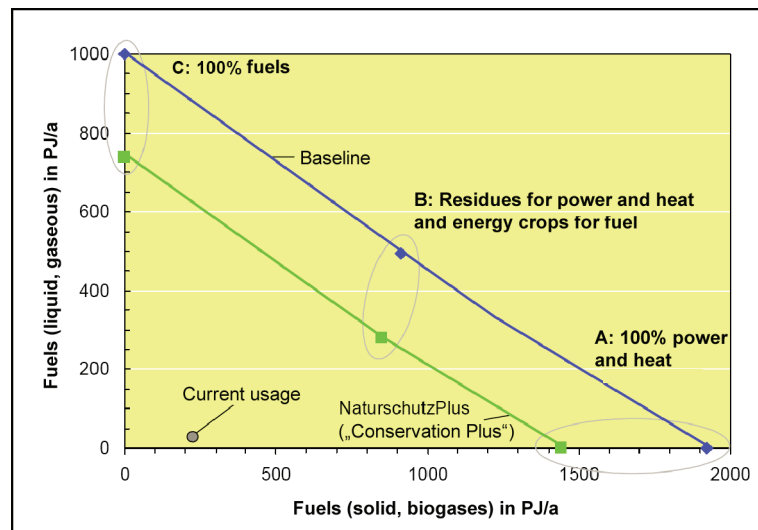

Fig. 6-5: Potential for using biomass taking account of competing usages in 2050 [8]

Recently, however, far more favourable estimates of potential have been published. For example, Nitsch *et al.* [10] reckons energy potential of 2 EJ/a for 2050, which, depending on the scenario, is used in various proportions to generate fuel and also to provide power and heat (Fig. 6-5). In addition, a 'NaturschutzPlus' (= Conservation Plus) variant has been included, which takes particular account of the specific nature conservation concerns.

The Institute for Energy and Environment (IE), Leipzig, study [9] illustrates the technical potential for power generation from biomass in the Federal Republic of Germany. The estimate assumes the available fuel potential is also used entirely and exclusively for power generation. The authors of the study state ([9]): *"The maximum power generation potential from biomass is available if wood and straw-based residues as well as energy crops are used as solid fuels, and other residues as well as landfill gas and sewage gas are used in biogasification processes; taken together, these amount to approx. 100 to 130 TWh/a (for comparison: current gross power generation is around 570 TWh/a)."*

It should be noted that this power potential is the equivalent of 0.36 to 0.47 EJ/a of consumer energy; converted to primary energy, this estimate falls somewhere in-between the figures in Table 6-2 and Fig. 6-5.

5. Assessment of the environmental and long-term economic rôle of biomass

Assessing biomass usage we can state the following:

- The use of biomass is not an interim solution but a definitive form of indirect use of solar energy. Biomass can be used long term just like other form of solar energy.

- Biomass can replace fossil fuels not only as an energy source but also as a feedstock. Biomass is probably the only feedstock alternative to fossil energy sources over the long term.
- Regional value creation from the use of biomass is a vitally important aspect on a global scale owing to its impact on employment and its significance to the economy.
- Seen from the same global point of view, however, energy crops may well face competition from foodstuff production since it is not simply space that is needed but arable land.
- The CO₂ avoidance costs of biomass cannot be stated uniformly since they relate closely to the respective usage pathway. The Nitsch *et al.* [10] study puts additional CO₂ avoidance costs at around €50/t CO₂ for power generation in a biomass heat and power station (CHP) compared with the current power generation mix of condensing power plants. These costs should fall to under €10/t CO₂ in 2030 according to the projected price assumptions in this study, i.e. a fall in the cost of technologies that use renewables coupled with an increase in the cost of fossil fuels; in 2050 the largest credits (approx. €-38/t CO₂) of all power producers from renewable energy sources should come from power generated using biomass heat and power stations. ([10] Fig. 2.12)
- Compared with heating a detached house using a combination of gas-fired boiler and low-temperature oil-fired boiler, providing heat from wood chips in a district heating plant now generates negative CO₂ avoidance costs of - €55/t CO₂. By contrast, wood-pellet central heating currently still produces additional costs of around €100/t CO₂, which should fall to just €10/t CO₂ by 2050 ([10], Fig. 2.13). These scenarios naturally depend to a great extent on assumptions concerning the evolution of the price of fossil fuels (see [10] section 6). When it comes to heating, the CO₂ avoidance costs from the use of biomass are also currently far lower and will presumably still be lower over the next 20 years than using other renewables to generate heat.
- The lack of any homogeneity and the fact that biomass by its very nature has a high water content are the technical drawbacks of using unprocessed biomass compared with fossil energy sources. This gives rise to more expensive combustion equipment and relatively poor efficiency ratios because part of the energy must be used to evaporate the water. The use of unprocessed biomass in many areas is comparable with the use of fossil energy sources under slightly more difficult conditions.
- Appropriate processing does mean that secondary energy sources such as wood pellets can also be produced from biomass. These products can easily hold their own against similar fossil energy sources.

The USPs and the long-term prospects of biomass need to be taken into account when looking to develop applications. Accordingly, the following order of priority ought to be set

when considering the use of biomass as a substitute for fossil energy sources and when defining research objectives:

1. Use of organic carbon compounds as feedstock
2. Biofuels
3. Decentralised combustion of biomass from mixed sources in close proximity to the place of production, preferably in a combined heat and power solution if local conditions permit
4. Central combustion of biomass collected from decentralised production locations, preferably in a combined heat and power (CHP) solution. It must nevertheless be remembered that the natural composition of biomass makes it a less efficient energy source for CHP than fossil energy sources, e.g. natural gas. It is therefore not expedient to promote CHP as an application for biomass at a time when biomass already enjoys very high subsidies and when high-yielding fossil energy sources such as natural gas or oil are still being used as pure fuels. This applies all the more in the event that decentralised methods of heat generation using biomass can be improved to such an extent that it becomes possible to fully extract the fuel's calorific value and also recover the water trapped in the biomass on the exhaust side.

Biomass comes in a multitude of forms, each of which presents its own advantages and drawbacks from an ecological point of view. These factors give rise to the following ranking:

First priority: exploitation of existing supplies of waste matter from industrial/agricultural/domestic sources (waste wood, organic production residues, organic household waste fraction);

Second priority: exploitation of crop residues, wood thinnings and other unharvested agricultural/forestry residues and accompanying materials;

Last priority: cultivation of crops specifically for use in energy production if they occupy arable land in competition with food crops.

Notes and references:

- [1] IEA: *World Energy Outlook 2002*, Fig. 13.12
- [2] BMU (F.Staiß et al.): *Erneuerbare Energien in Zahlen – nationale und internationale Entwicklung – Stand: März 2004*, page 26, available at: <http://www.erneuerbare-energien.de>
Original source: ZSW-Zentrum für Sonnenenergie und Wasserstoff Forschung, Stuttgart
- [3] BMU (F.Staiß et al., see [2]), page 12 (edited)
- [4] BMVEL: *Leitfaden Bioenergie*; Förderkennzeichen FKZ97 Nr022, page 17,
available at: <http://www.fnr-server.de/pdf/literatur/lfgesamt.pdf>,
Original source: Kaltschmitt 1997, available at: <http://www.fnr-server.de/pdf/literatur/lfgesamt.pdf>
- [5] BMVEL: *Leitfaden Bioenergie* (see [2]), accompanying CD: Table 2.9.1 (edited)
- [6] BMVEL: *Leitfaden Bioenergie* (see [2]), page 33 (especially Table 2.6)
- [7] Source: BMVEL: *Leitfaden Bioenergie* (see [2]), CD Table 2.9.3 (edited), original source: BMWi 1994
- [8] From [10] Fig. 5.2
- [9] IE Leipzig: *Monitoring zur Wirkung der Biomasseverordnung auf Basis des EEG*, FuE Vorhaben FKZ 201 41 132, final report 15.12.2003; available at: <http://www.umweltbundesamt.org/fpdf-l/2438.pdf>
- [10] Nitsch, J. et al.: *Ökologisch optimierter Ausbau der Nutzung erneuerbarer Energien in Deutschland*, study commissioned by BMU. FKZ 901 41 803, (2004), page 63 ff.
http://www.erneuerbare-energien.de/files/pdfs/allgemein/application/pdf/nutzung_ee_lang.pdf

7 Energy for road transport – alternative fuels

1. Introduction

An essential component of any energy policy must be to save energy wherever reasonably possible. While overall energy consumption in Germany has remained more or less constant over the past 30 years, the performance of individual sectors of the economy varies enormously: industrial consumption has fallen by 24.4% and private domestic consumption by 3.4% over the period 1973-2002. By contrast, consumption in the road transport sector has increased by 65% as a result of the trend towards more and bigger cars [1].

In this chapter of our report we therefore examine the issue of how energy consumption and greenhouse gas emissions can be reduced through the use of alternative fuels and new drive concepts, and what sort of reductions are viable in the road transport sector by 2020, a sector that accounted for just under 30% of consumer energy consumption and a good 20% of CO₂ emissions in Germany in 2000 [2]. This analysis is essentially based on the results of a recently published European study [3, 4]. A Europe-wide analysis of the future traffic scenario and associated potential savings would seem justifiable since developments in Germany and the other European countries are likely to be similar in this area. To round off the discussion we focus on the specific conditions in Germany.

2. Options for alternative fuels and their assessment

As is well known, the European Commission is aiming to gradually introduce alternative fuels as a substitute for mineral oil in the road transport sector to meet the EU target of 20% penetration by 2020 [5]. The aim of replacing mineral oil by alternative fuel sources is *to improve the security of energy supply and reduce greenhouse gas emissions*.

	2010	2015	2020	New proposal 2020
Biofuels	5.75%	7%	8%	15 %
Natural gas	2%	5%	10%	10 %
Liquefied Petroleum gas				5 %
H ₂	-	2%	5%	a few %
Total	7.75%	14%	23%	> 30 %

Table 7-1: EU targets for increasing market share of alternative fuels (based on [3,7])

The European Commission has singled out biofuels, natural gas and hydrogen as the main candidates for alternative fuels [6]. The long-term development potential of these fuels means they are likely to contribute significantly to the aforementioned targets at costs which are economically sustainable. Table 7-1 illustrates the way in which it is expected to achieve the 20% substitution target by 2020 using these three alternative fuels. The last

column ('New proposal 2020') shows more recent thinking on the issue with a substitution target of 30% and a different split across the various alternative fuels to reflect latest developments.

Any overall assessment of the envisaged alternative fuels must take account of multiple criteria such as the long-term security of energy supply, reduction in greenhouse gas emissions, improvement in air quality and international competitiveness of the industry. It must also adopt a 'well-to-wheels' approach, covering each and every stage of the process from primary energy source through to vehicle consumption per kilometre driven.

A comprehensive study drawn up by the European oil and car industries covers all these stages involving over 400 energy pathways [7]. The study analyses energy consumption, greenhouse gas emissions and costs for the three main options: biofuels, natural gas and hydrogen, along with petrol and diesel as reference fuels. It shows that the transition from existing mineral-oil-based fuels to alternative fuels, which can substantially reduce CO₂ emissions, in fact leads to higher energy consumption in many instances [4]. Thus the limited potential of alternative energy sources not only involves selecting the fuel but means energy efficiency has to be optimised during the manufacturing process and when the fuel is used in the vehicles.

2.1 Biofuels

The use of biomass as a fuel source provides a basic indigenous contribution to the energy supply in a sector of industry that has been hitherto almost totally dependent on oil imports. The combustion of biofuels is also largely neutral in terms of greenhouse gas emissions. But the production costs, which currently lie at €600-800 per metric ton, effectively exceed the average for mineral-based fuels over the past few years by a factor of 2.5 to 3.

The ultimate share of biofuels in the energy economy will essentially depend on how much agricultural and forestry land can be earmarked specifically for the purpose. Bioethanol and biodiesel (first-generation biofuels), which are currently being manufactured from sugar beet or rape seed oil on a large scale, could supply around 7-8% of the fuel market if all the accessible arable land in the European Union were used [4].

Two new technologies for manufacturing biofuels are currently being investigated in lighthouse projects: the *conversion of biomass to ethanol* using enzymes and the *manufacture of synthetic diesel* (second-generation biofuels) via a two-stage process involving the gasification of biomass to produce synthesis gas (consisting of hydrogen and carbon monoxide) and subsequent liquefaction in a Fischer-Tropsch process. The feedstock used includes waste from agriculture, forestry and the wood-processing industries or specially cultivated crops. According to estimates, a 15% market share could be achieved for biofuels (conventional plus synthetic) in the EU [4] (see Table 7-1).

Synthetic diesel from biomass offers numerous advantages: its use would take the strain off refineries, already stretched by a surplus production of gasoline relative to diesel and

struggling to cope with the spiralling increase in demand for diesel. This situation is already having an adverse effect on the energy and greenhouse-gas balance of diesel compared with petrol. Furthermore, synthetic diesel as a tailor-made, top-grade fuel could promote the development of more efficient, cleaner engines. Finally, synthetic diesel can be blended in any ratio with mineral diesel and therefore opens up the prospect of a highly flexible market structure.

A comparison of the three biofuels: bioethanol, biodiesel and synthetic fuel (brand name 'SunFuel') in relation to CO₂ reduction potential, required cultivation area and costs (Table 7-2) underlines the superiority of synthetic biofuels, which achieve close to 1% CO₂ reduction per 1% blended fuel.

	<u>CO₂ reduction</u>	<u>Area of land under cultivation</u>	Costs
	1% fuel	1 g CO ₂ /km reduction	
	%	Million ha	€/MJ
Ethanol:	0.35	1.77	0.028
Biodiesel:	0.64	2.69	0.017
SunFuel:	0.83	0.67	0.020

Table 7-2: Comparison of various biofuels (based on [7])

2.2 Natural gas

The lower greenhouse gas emissions from the use of natural gas (CNG, LNG: compressed/liquefied natural gas, calorific value ~0.2 kg CO₂/kWh) compared with the oil-based products petrol and diesel (~0.3 kg CO₂/kWh) are attributable to the lower specific carbon content of methane (CH₄), the main constituent of natural gas.

The bulk of the world's natural gas reserves lie within Europe's reach. Natural gas could therefore become the main component for developing alternative fuels over the medium term, i.e. contribute around half of the 20% substitution target set for 2020 (Table 7-1). On the other hand, 10% of the fuel market would only constitute 5% of the projected total consumption of natural gas in the EU for 2020 and would therefore have a minimal impact on the supply situation.

Based on the European study [8], Fig. 7-1 compares the energy consumption (Energy) and greenhouse gas emissions (GHG) of natural gas vehicles for various gas supply pathways and vehicle technologies for petrol- and diesel-engine cars, covering models currently available, and technologies expected post-2010.

Using vehicle technologies currently on the market, the greenhouse gas emissions of natural gas passenger cars ('CNG (4000 km) – 2002') are around 20% less than their petrol counterparts and on a par with diesel-fuelled cars. Petrol-engine efficiency is expected to improve further in the future, whereas diesel engines offer relatively little scope for further improvement. Consequently, cars driven by both types of engine are expected to reach the same levels of efficiency in terms of fuel consumption and greenhouse gas emissions by 2010. By then, cars fuelled with compressed natural gas can be expected to be producing

15% lower greenhouse gas emissions thanks to improvements in internal combustion engine technologies ('CNG (4000 km) - 2010'). The optimisation of engine designs to handle higher compression ratios and hence better exploit the properties of natural gas could cut greenhouse gas emissions by up to 35%. Hybrid technologies combining an internal combustion engine and an electric motor are capable of improving efficiency across the board and, in turn, generating further reductions in fuel consumption and greenhouse gas emissions.

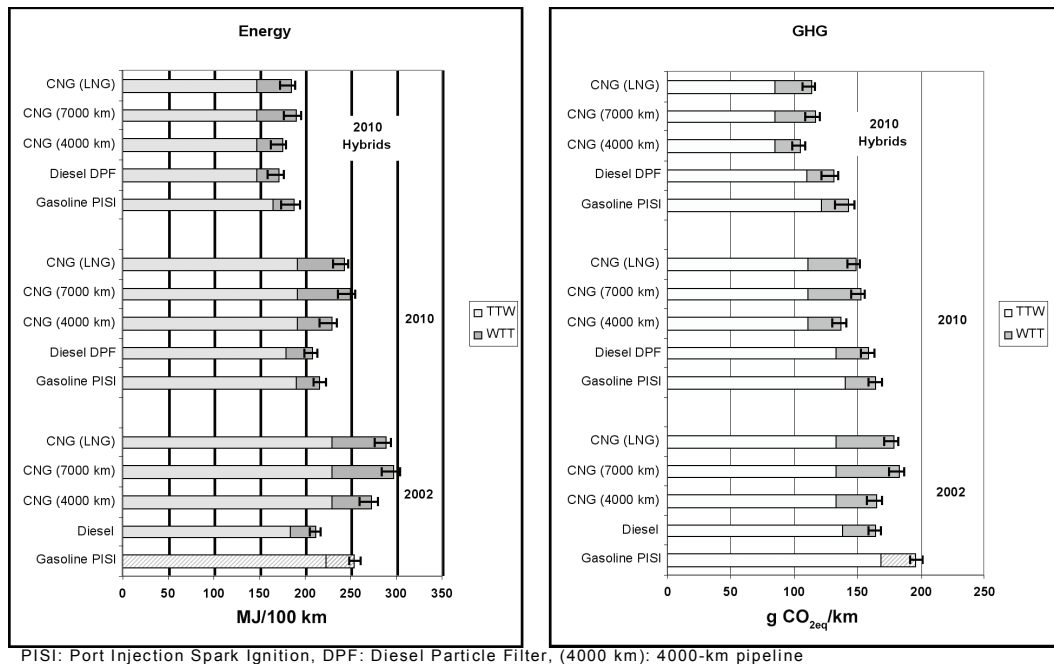

Fig. 7-1: Fuel consumption and greenhouse gas emissions for CNG cars compared with petrol and diesel cars (from [8])

Lower pollutant emissions are another advantage of natural gas vehicles. Most notably, their lower particulate emissions by comparison with diesel engines mean that CNG vehicles will be able to meet the stricter emissions standards expected in the future without additional equipment such as a particulate filter.

Vehicle fuel technology based around natural gas is well advanced. There are already a range of bi-fuelled models on the market that will run on natural gas and gasoline. Over the past few years several large manufacturers have developed variants specifically for natural gas.

A key factor in the development of natural gas as a fuel for the road transport sector is the rapid expansion of the necessary filling station infrastructure. Market studies indicate that around 25% of filling stations need to be equipped with pumps for natural gas in order to raise the market share for this type of fuel to 10%. Even with a market share of just a few percent, natural gas could compete economically thanks to the lower cost of raw materials compared to oil.

2.3 Hydrogen

Hydrogen has the potential to become a universal energy carrier and transport energy from any primary source to any potential consumer (this also offers the highest possible degree of security of supply). The conversion of energy from hydrogen generates no greenhouse gas emissions and so the preceding stages of hydrogen production are decisive in terms of fuel consumption and emissions. Consequently, an overall analysis of the product chain from the source to the consumer is essential to provide an accurate assessment.

Based on the European study [8], Fig. 7-2 illustrates energy consumption and greenhouse gas emissions for the two drive types for hydrogen cars, internal combustion engine (ICE) and fuel cell systems (FC), comparing these with the figures for vehicles fuelled by petrol, diesel and compressed natural gas (CNG). A clear shift is apparent from consumption-dominated balances (TTW: tank-to-wheels) for petrol, diesel and natural gas towards largely production-dominated balances (WTT: well-to-tank), and even exclusively so in the case of greenhouse gas emissions, for hydrogen.

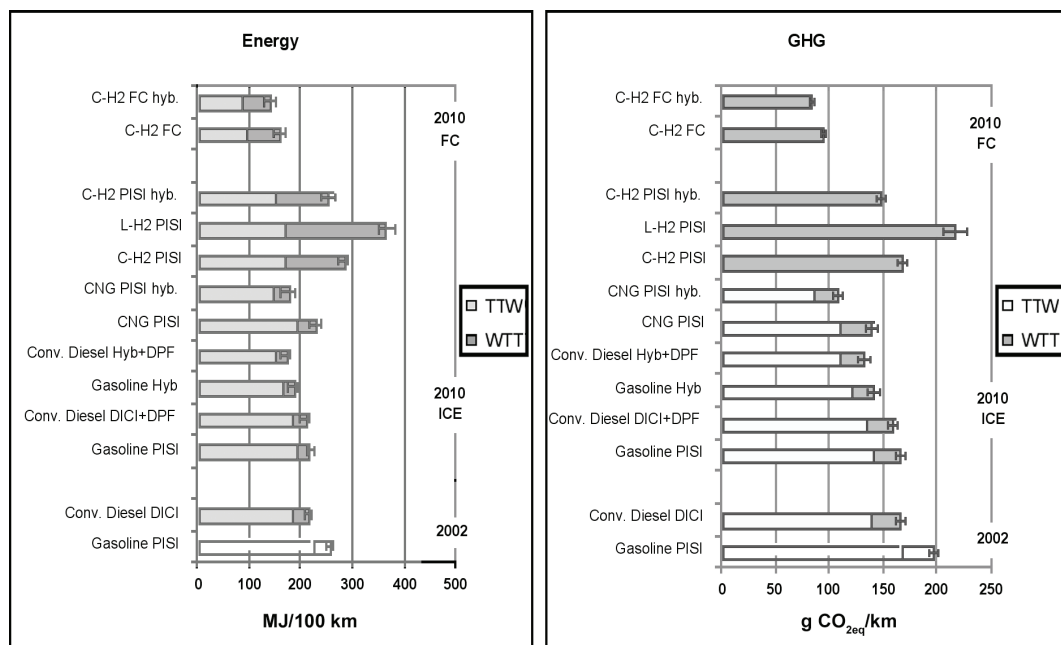

DICI: Direct Injection Compression Ignition, Hyb: Hybrid operation, mainly with electric drive, C-H2: compressed hydrogen, L-H2: liquid hydrogen; other abbreviations as in Fig. 7-1

Fig. 7-2: Energy consumption and greenhouse gas emissions for hydrogen cars for various drive technologies compared with natural gas, petrol and diesel cars (from [8])

Internal combustion engines with liquid hydrogen storage (L-H2 PISI) produce the highest figures for energy consumption and greenhouse gas emissions; fuel cell systems (FC) return the lowest figures. Fuel cell systems, taken in conjunction with the technology expected for 2010, generate greenhouse gas emissions 50% below the figures for conventional petrol and diesel cars (despite the underlying assumption that hydrogen is produced from fossil sources using natural gas steam reforming).

Hydrogen production by means of natural-gas steam reforming, coal gasification or hydro-electrolysis is a mature technology involving processes that have been used on a large

industrial scale for many years. The CO₂ emissions associated with resorting to fossil energy sources could be reduced by around 90% through CO₂ sequestration (CO₂ capture and storage). The use of electricity generated from renewable sources such as wind and solar power for electrolysis results in high energy losses and at best only viable in niche applications. It is generally much more efficient to feed power from renewable sources directly into the power grid.

The investment costs of building up an infrastructure for hydrogen cars are comparatively low at around €500 per vehicle, assuming a customer base of approx. 500 vehicles per filling station. The running costs for a hydrogen-fuelled vehicle using highly efficient fuel cell systems are likely to be comparable with current fuel costs. The main problem relates to those vehicles where a substantial reduction in costs and improvement in reliability and service life would need to be achieved through further technical advancements.

3. Potential savings for road transport up to 2010 and 2020

The accuracy of projected potential savings and CO₂ reduction in the road transport sector naturally varies enormously looking at the two time horizons of 2010 and 2020. While developments for the period up to 2010 are more or less predictable, there is no way of predicting what will happen up to 2020. All we can do is to estimate the potential opportunities under a defined set of conditions.

The first thing we can say is that the European Commission's envisaged targets of around 8% market share for alternative fuels in the EU in 2010 and approximately 20% in 2020 (Table 7-1) seem realistic. The envisaged substitution scenario also holds out the prospect of ongoing expansion of alternative fuels. Nonetheless, clear-cut political decisions and adequate government financial incentives will be needed if these targets are to be met.

The potential savings of the discussed fuel and drive concepts up to 2020 can be assessed as follows (this applies initially to the EU [3,4], but equally to Germany with some minor variations [9]):

- *Increased efficiency* of diesel and petrol engines offers the largest savings potential in the period up to 2010 and will also continue to play an important role in the following decade. Increased efficiency should stem rising energy consumption, which would be expected to rise without these measures due to an initial ongoing increase in traffic volumes [10]. Average specific fuel consumption for passenger cars in Germany fell from 9.4 to 8.0 litres per 100 km between 1990 and 2003 [11]. It can be safely assumed that this trend will continue, in which case we can expect to see consumption fall to 6.5 l/100 km in 2020 provided the momentum is maintained.
- *Biofuels* will only appear in the form of fuel blended with up to 5% bioethanol/biodiesel by 2010 and could reach the 5.75% target market share in 2010. From 2010 synthetic fuels made from biomass (BTL) will increasingly replace conventional biofuels. Overall, biofuels could account for a market share of 8% or higher by 2020.

- *Compressed natural gas* (CNG) will only account for a 0.5-1% market share by 2010, but could potentially rise way above 5% by 2020 (the 10% target in the EU scenario seems realistic). Natural gas can be used with advanced vehicle technologies, but requires significant expansion of the filling station network and a wider range of optimised natural gas vehicles.
- *Liquefied petroleum gas* (LPG) is likely, albeit on a more modest scale, to account for a growing share of the alternative fuel market (the 'New proposal 2020' puts its contribution at 5% in 2020).
- *Hydrogen* by contrast will only become more important as an alternative fuel post-2020. By 2020 its share will only rise to around 2% (cf. downgraded forecast in the 'New proposal 2020'), nonetheless a figure already regarded as a critical threshold for moving forward with market penetration.

Overall, alternative fuels could already replace 70 million tonnes of oil throughout Europe in 2020, according to the European Commission scenario (Table 7-1, column 3) [4]. This quantity would be roughly equivalent to the EU's estimated entire North Sea oil production in 2020. The saved CO₂ emissions of 80 million tonnes of CO_{2eq} would account for around 10% of all the current emissions in the road transport sector [4].

To estimate the CO₂ emissions saved through this substitution, the forecast share of each of the alternative fuels needs to be multiplied by the corresponding CO₂ reduction potential. This then gives a reduction of CO₂ emissions per kilometre driven for 2020 in the region of 10% of current emissions (biofuels contribute 4-6%, natural gas and LPG combined 3-5% and hydrogen 0.5-1%). Since we assume that traffic volumes in Germany will initially increase further over the next few years, before decreasing slightly from around 2010 [10], the total CO₂ emissions generated by transporting people will only decrease slowly in the early stages. By 2020 we can then assume an annual reduction of total CO₂ emissions of around 8% (10%-(8x0.5%-10x0.2%)) of the 2002 figures. This would be the equivalent of cutting around 20 million tonnes of CO₂ per year (8% of 878 x 0.283 Mt CO₂ in 2002).

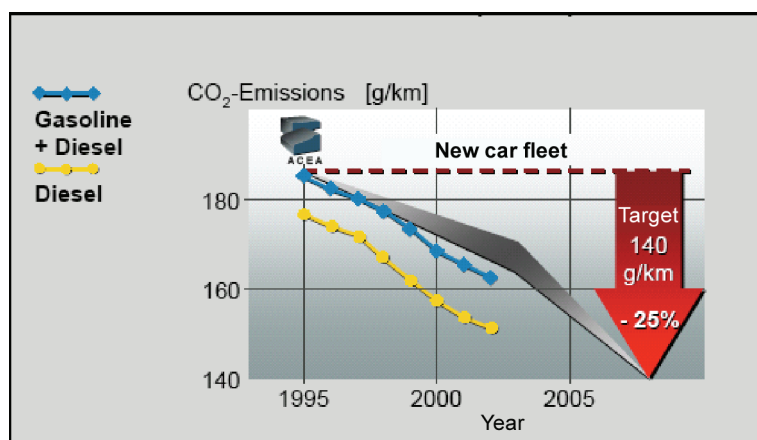

Fig. 7-3: Voluntary agreement of European automobile manufacturers (from [7])

The 'ACEA voluntary agreement' [12] signed by the European Automobile Manufacturers Association (ACEA) illustrates clearly that the aforementioned reduction targets amount to more than just good intentions. The voluntary agreement is testimony to car manufacturers' commitment vis-à-vis the European Commission to reduce CO₂ emissions for new cars by 25% from 185g/km in 1995 to 140g/km in 2008 (see Fig. 7-3), with an interim target of 165-170g/km in 2003. The latest monitoring figures for 2003 were 165 g/km, reflecting the fact that the EU automotive industry is well on track to delivering the promised reductions.

Apart from the potential savings from new fuels and improved engines discussed so far, limited additional savings are tied up with an individual's driving style. These savings relate to eco-friendly driving and, as a fairly draconian measure, universal speed limits. One study [13] has shown that limiting speeds to 100 km/h on motorways and 80 km/h on country roads in Germany could reduce private passenger car fuel consumption by 4.8%.

In conclusion it is clear that the huge efforts being made in the road transport sector through the gradual introduction of alternative fuels and new innovative drive concepts could cut around 10% of annual CO₂ emissions per kilometre driven by 2020 compared with the current situation. Since the specific impact of CO₂ savings needs to be offset against the initial further increase in traffic volumes, there will only be a slow reduction in CO₂ emissions volumes over the next few years. By 2020 there is, however, likely to be an overall annual CO₂ reduction of around 8% compared with the 2002 figure, the equivalent of around 20 million tonnes of CO₂ per year.

Notes and references

- [1] Federal Statistical Office Germany: Verkehr und Umwelt, Umweltökonomische Gesamtrechnung 2004; Wiesbaden 2004
- [2] *Fortschrittsbericht 2004 – Perspektiven für Deutschland*, issued by the German government, October 2004
- [3] *Market Development of Alternative Fuels*, Report of the Alternative Fuels Contact Group, 2003, <http://www.climnet.org/pubs/AltFuel2003.pdf>
- [4] F. Söldner, *Alternative Treibstoffe zur Sicherung von Energieversorgung und Umwelt*, in: *Perspektiven für die Energie der Zukunft*, Deutsche Physikalische Gesellschaft – Energy Working Group (13 presentations at the Munich conference, 2004), p. 169-185
- [5] Communication from the European Commission, European transport policy for 2010: time to decide, COM(2001) 370
- [6] Communication from the European Commission, *Alternative fuels for road transportation and a set of measures to promote the use of biofuels*, COM(2001) 547
- [7] F. Seyfried, *Potentiale synthetischer Kraftstoffe für die Mobilität der Zukunft*, Energy Working Group presentation at the 2005 DPG conference in Berlin (conference proceedings in the pipeline)
- [8] *Well-to-Wheels Analysis of Future Automotive Fuels and Power Trains in the European Context*, CONCAWE/EUCAR/JRC, <http://ies.jrc.cec.eu.int/Download/eh/>
- [9] *Perspektiven für Deutschland – Unsere Strategie für eine nachhaltige Entwicklung – Fortschrittsbericht 2004*, Berlin 2004, p. 170-196

- [10] The *Energiereport IV* assumes a 0.5% annual increase in kilometres driven in Germany 2000-2010 and a slight decrease of 0.2% per year that will not kick in until 2010-2020.
Energiereport IV – Die Entwicklung der Energiemärkte bis zum Jahr 2030 – Energiewirtschaftliche Referenzprognose (abridged version), study commissioned by the Federal Ministry of Economics and Technology (BMWA) and conducted by The Institute of Energy Economics at the University of Cologne (EWI) and Prognos AG, April 2005, p. IX
- [11] Bundestag document 15/3740, response of the German government to *Auswirkungen des weltweiten Energie und Ressourcenbedarfs auf die globale Klimaentwicklung*, Number 30
- [12] As [2], p. 100
- [13] *The Efficiency of Measures to Reduce Petroleum Consumption in the Concept of Supply Constraints*, German Institute for Economic Research (DIW), commissioned by the Federal Ministry of Economics (BMfW), 1996

8 Nuclear power

1. Overview of nuclear power usage in Germany

Nuclear power remains the most important primary energy source for power generation in Germany. In 2004 nuclear accounted for 27.5% of the 606.5 billion kWh total gross power generated, topping the 26.1% generated from lignite. 17 nuclear power plant units with an installed net output of 20,303 MW are currently on stream. In 2004 they produced – still including the Obrigheim plant that was finally closed down in May 2005 – a combined 167.1 billion kWh. Despite the Stade nuclear power plant being closed down in November 2003, the power generated from nuclear was a good 1% higher than in the previous year. Low fuel costs make nuclear power plants ideal as baseload power plants; they account for around half of the power supplied in this way.

Thanks to their low power generation costs and high reliability (average availability approx. 90%), the German nuclear power plants have met the expectations placed on them during development, i.e. a cost-effective supplement for fossil energy sources, which are limited by available resources, and improved security of supply. Over time it became apparent that nuclear power was an equally compelling proposition to meet the eco-friendliness and pollution control requirements, requirements that only became prominent at a later stage. Nuclear power plants generate power virtually CO₂-free and so contribute to efforts to combat global warming. Particularly with baseload power stations, which are run virtually throughout the year at full output, this characteristic becomes important. If the decision had been taken at the time to build coal-fired instead of nuclear power plants, using them to generate the same annual quantity of power, the CO₂ emissions in Germany would have been approx. 160 million tonnes higher per year.

If we were now to replace these nuclear plants with modern fossil-fired plants with the kind of characteristics described in Chapter 3, CO₂ emissions would still rise by 100-120 million tonnes (the higher figure applies to retaining the current mix of fossil fuels, the lower figure for doubling the natural gas component in fossil power generation from the current 16% to 32%).

The contribution of nuclear power plants to climate protection has increased by as much as around 10% since the base year 1990 because nuclear now generates 10% more power than in 1990.

While the development and usage of nuclear power enjoyed widespread political and social backing in the early days, throughout the 1970s and particularly since the Chernobyl reactor accident in 1986, the debate surrounding nuclear power has become increasingly controversial.

The German government has been pursuing a policy of gradually abandoning nuclear power since 1998. It argues nuclear power cannot be justified in the long run in light of the technical risks, uncertainty surrounding disposal and the risk of proliferation. Moreover, uranium reserves might not support the long-term use of nuclear power.

In 2000, the German government therefore negotiated with the utility companies an agreement under which limits were placed on the operating life of existing nuclear power plants, expressed in terms of a residual electricity quantity specified for each individual nuclear power plant based on its age. Once this quantity has been reached, the operating license will expire [1]. This compromise involved calculating the residual electricity quantities on the basis of an agreed total 32-year operating life for each nuclear power plant. This figure was then included in an amendment to the Atomic Energy Act that came into force in 2002.

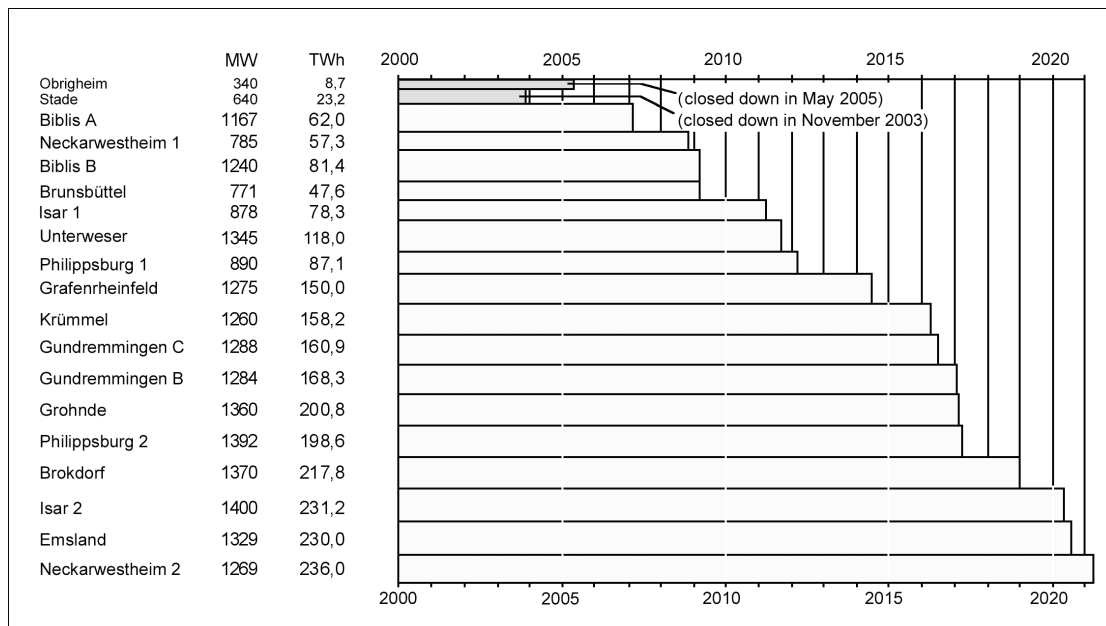

Fig. 8-1: Operating life of German nuclear power plants in accordance with residual electricity quantities

To date only the relatively small nuclear power plants Stade (672 MW, November 2003) and Obrigheim (340 MW, May 2005) have been shut down as part of the phase-out policy. From around 2008, large units are due to be shut down based on the age of each plant. Shortly after 2020, the most recent nuclear power plants will also have to be shut down unless the current time frame is altered.

2. Contribution of nuclear energy to climate protection over the medium term (up to 2020)

The current German policy position would effectively phase out nuclear power generation in Germany by around 2020. As indicated in other chapters, a small portion of nuclear power at best can be replaced by additional renewable energy or offset by increased savings over this period. Therefore we need to establish whether, and if so, to what extent, there is scope for nuclear power to continue supplying CO₂-free power in Germany over a longer period. Essentially this could involve extending the operating life of existing nuclear power plants and/or building new ones.

This is not the place to evaluate nuclear energy or perhaps 'venture an opinion' 'for' or 'against'. The option of building new nuclear power plants will not be discussed here, particularly since no one seems willing to make these kinds of investment decisions for the foreseeable future.

The extent to which extending the operating life of existing nuclear power plants is a realistic option needs to be studied carefully. In this respect the aforementioned objections raised against nuclear energy need to be assessed in terms of how relevant they are to any decision to (re-)approve longer operating lives for existing nuclear power plants, and other factors taken into account:

Reactor safety

The limited operating life stipulated in the agreement between the German government and the power utilities falls substantially below the technical service life of the plants. Relevant studies have shown that the component crucial to service life, the reactor pressure vessel, can be operated in most German nuclear power plants for at least 50 years and, in some cases, for far longer without compromising safety [2]. This tallies with estimates in other countries. For instance, 32 of the 104 nuclear power plants in the USA have already been granted an extension to their license from the original 40 to 60 years [3]. In Switzerland replacement capacity for Beznau 1 and 2 and Mühleberg is planned for around 2020 when the plants will be around 50 years old.

German nuclear power plants have always boasted very high levels of safety compared with their international counterparts. In addition, the level of safety has even been improved further over the years, as reflected in the increasing improvements in plant availability and declining frequency of safety shutdowns. The few notifiable incidents continue to have a low impact on safety.

From the standpoint of safety there is no reason why plants should not be allowed to continue operating.

Final repositories

Extending the service life will generate additional quantities of radioactive waste. In the case of high-level, heat-generating waste, the quantities are directly proportional to the number of operating years and the nuclear fuel consumed. But when it comes to low and medium-level waste that is not heat-generating, the additional quantities are far less proportionally. This is because the quantity of waste produced by dismantling plants, which accounts for a substantial portion of the required repository capacity, remains unaffected. These additional quantities do not effectively change the nature of the disposal problem since the volume issue is far less important.

By international standards, Germany has a very advanced integrated waste disposal concept. The German approach exceeds the requirements of most other countries by also

envisaging a deep geological repository for non-heat-generating waste. This repository, the Konrad mine shaft, was licensed in 2002 following a 20-year planning approval procedure. However, the approval cannot be implemented since an appeal has been lodged and the government has not ordered immediate enforceability. It is very regrettable that the extensive exploratory work on the Gorleben salt dome, the candidate for the final storage of high-level, heat-generating waste and spent fuel elements, has been deadlocked since October 2000. Otherwise we would already have a final, in all probability favourable, result regarding the suitability of Gorleben. The exploratory tests on the Gorleben salt dome completed thus far have not uncovered any geological findings to suggest the site is unsuitable. The German government confirmed as much in the June 2000 agreement with the power utilities [4].

Irrespective of decisions regarding the future role of nuclear energy in the German power supply landscape, steps need to be taken to ensure that the repository exploration and licensing process is pushed forward quickly so that a solution to the disposal problem is not passed on to the next generation. The creation of final repositories, for which the German government is responsible under the Atomic Energy Act, is not an unsolvable problem, but requires political action.

In any case, there is no reason why the service life should not be extended from a waste disposal standpoint.

Uranium supplies

Uranium is an abundant mineral. Claims that uranium will only last 40 (or 50) years are founded on a fundamental misconception about current known reserves and total economically viable world uranium deposits. Firstly, there is much more uranium than has been explored and found to date. Secondly, a large proportion of the uranium not currently classified as 'reserves' can be used economically despite higher extraction costs since the uranium costs only account for a small portion (5-10%) of the power generation costs in nuclear power plants. Uranium deposits are classified into three production costs categories. The known, assured and estimated additional uranium deposits in the two lower costs categories (up to US-\$80/kg uranium) are 3.2 million t or the equivalent of 47 times current annual demand, according to figures from the OECD's Nuclear Energy Agency (NEA) [5].

Intensive prospecting essentially took place only between 1970 and 1985, while the associated annual costs only corresponded to a small fraction of the investment in exploring for other energy raw materials such as oil. The construction of nuclear power plants has fallen sharply since the 1980s and, as such, the demand for uranium remained well below expectations. As a result, the price of uranium fell, particularly as high civilian stocks and uranium from dismantling nuclear weapons were forcing their way onto the market. Consequently, uranium exploration was suspended almost entirely and various uranium mines closed. Uranium prices have recovered to a certain extent over the past two years, preparations have been made to reopen a few mines. Increasing uranium prices have also resulted in a redoubling of efforts to find new deposits so that known reserves will continue to increase.

In terms of assured uranium reserves, Australia tops the list, followed by Kazakhstan, the USA, Canada and South Africa. Over 60% of reserves are in OECD countries [6]. This geographic spread ensures a high security of supply.

There is no reason the service life of German nuclear power plants should not be extended from a uranium supply standpoint.

Proliferation risk

Various developments over the past few years have led to concerns regarding the proliferation of nuclear weapons and relevant know-how. Preventing proliferation remains high on the international community's agenda.

In Germany all nuclear activity is subject to Euratom and IAEA safeguards, while the provisions of the Foreign Trade Act (AWG) govern all nuclear exports. Effective controls are in place to prevent fissile material from being diverted and sensitive know-how from being siphoned off.

Maintaining nuclear technology expertise

In addition to the technical state of plants, plant safety depends on the expertise of operating personnel and the supervisory authorities as well as the consultative committees and independent experts commissioned by those authorities. We are currently in the midst of a drastic generation change so we need to ensure that competent junior staff and managers are trained and appointed in good time in all the relevant departments. Steps also need to be taken to ensure the knowledge built up over decades is passed on to these new recruits. Continuing support for research and teaching in the relevant engineering fields is essential in this respect. Since the problem affects operators just as much as the national and regional supervisory bodies created under the Atomic Energy Act as well as the specialist organisations engaged by these bodies, this task needs to be tackled jointly by all the organisations involved.

Compatibility with the phase-out policy

The German government does not see the orderly phasing out of power generated from nuclear fuels as an isolated goal but as part of a policy described as an energy U-turn. Over the past few years it has become all too clear that the use of renewables and combined heat and power generation could not be expanded as fast as expected. In particular the use of offshore wind turbines needed more time to overcome specific technical problems (see Chapter 5). Accordingly the wind turbine manufacturers have asked for nuclear power stations to be left running for another eight to ten years to give the offshore technology time to be perfected [7]. The fear is that otherwise the imminent boom in power plant construction to replace old fossil and nuclear power plants will simply bypass wind power. As a result, the structure of the power plant pool will be set in stone for a long time to come.

Against this backdrop, extending the operating life of nuclear power plants may be wholly in line with the German government's energy U-turn policy.

3. Conclusions

Nuclear power plants contribute to climate protection. At best, only a fraction of these can be replaced by other CO₂-free energy sources over the medium term. Consequently, the recommended scenario would be to allow nuclear power plants to run longer than envisaged hitherto. They can continue to contribute to climate protection for a limited time without compromising safety. From a uranium supply standpoint there are no reservations, and the disposal problem would not be significantly compounded as a result. The proliferation problem would be unaffected. Nonetheless, steps should be taken to maintain the nuclear technology expertise surrounding the requisite operating infrastructure, including the supervisory authorities and independent experts, and to develop these in accordance with international best practice. Progress needs to be made to ensure repositories are set up quickly, irrespective of the question of whether to extend the service life of nuclear power plants or not.

Notes and references

- [1] Agreement between the German government and the power utilities dated June 14, 2000 (<http://www.bmu.de/atomenergie/doc/4497.php>)
- [2] Manfred Erve, *Bewährung des Werkstoffkonzeptes im Betrieb von Kernkraftwerken und zukünftige Herausforderungen an die Werkstoffe*. 9th Materials Conference, TU Graz (Processing and Properties of Materials – Today and Tomorrow), Graz November 19, 2004
- [3] Nuclear Energy Institute (USA), Newsroom/License Renewal (<http://www.nei.org/index.asp?catnum=3&catid=14>)
- [4] Agreement between the German government and the power utilities dated June 14, 2000, Annex 4 (http://www.bmu.de/files/pdfs/allgemein/application/pdf/atomkonsenskonsens_anlagen.pdf)
- [5] *Uranium Resources, Production and Demand*. OECD-NEA, Paris 2003
- [6] *Reserven, Ressourcen und Verfügbarkeit von Energierohstoffen 2002*. Federal Institute for Geosciences and Natural Resources (BGR), Hanover 2003 (p. 227)
- [7] Fritz Vahrenholt, Repower Systems AG, in numerous articles and interviews, e.g. *Wir müssen uns Zeit kaufen*, Der Tagesspiegel, June 05, 2005

9 Fossil-fired power plants with CO₂ sequestration

1. The problem

Unfortunately, we can no longer seriously deny the high probability of global climate change as long as our energy consumption and consequent CO₂ emissions continue to increase. Moreover, the fact that natural resources of fossil fuels are limited makes it inevitable that we will have to learn to live without this energy source in the long term. However, many analysts and scientific advisory boards (e.g. WBGU, the German Advisory Council on Global Change), as well as representatives of the relevant industry sector, claim that a timely switch from fossil fuels to sustainable energy sources is not feasible, implying that a continuing and even more intensive use of fossil fuels will be unavoidable. Experts further explain that this is reinforced by the fact that a large part of the world's population has a legitimate and therefore irrefutable pent-up demand for the use of energy sources. Inevitably, this poses the following problem: How can we ideally continue to use fossil fuels for transport, heat generation and power plants, while at the same time ensuring that the influence this has on the global climate is kept within predefined limits by means of downstream measures?

One option being considered in this respect, which is particularly suited for use in central power stations and large industrial plants, is to separate the CO₂ produced during combustion from the other flue gases at a relatively low cost, to condition it for transport and to safely store it in suitable underground repositories on a long-term basis. This process, known as "Carbon Capture and Storage (CCS)", a concept that was already discussed many years ago when it was still considered a wild idea, has now reached a certain level of maturity, both in theory and in practice. Because CCS seems to be relatively cost-effective, it is actually the preferred course of action in the endeavour to avoid an impending climatic change.

The technical challenges consist of capturing the CO₂ (Section 2), conditioning it for transport, actually transporting it and finally storing it safely on a long-term basis (Section 3). In Section 4 the experience from first pilot installation is reported and a tentative evaluation of CCS is given in Section 5. The facts reported in this paper are based largely on the reviews [1], [2] and [3].

2. The process of separating CO₂

The most costly and least established element of the "separation – transport – storage" process chain is the separation procedure. However, it is likely that the next ten years will witness the construction of large-scale demonstration power plants even for this process.

There are several technical options for capturing CO₂ (see overview in Fig. 9-1):

- (1) Process involving capture after combustion (post-combustion capture),
- (2) Process involving separation of CO₂ before combustion (pre-combustion capture), and
- (3) Oxy-fuel process, in which combustion takes place with almost pure oxygen instead of air, resulting in flue gas that consists mainly of CO₂, apart from the contained water vapour, which still needs to be separated off.

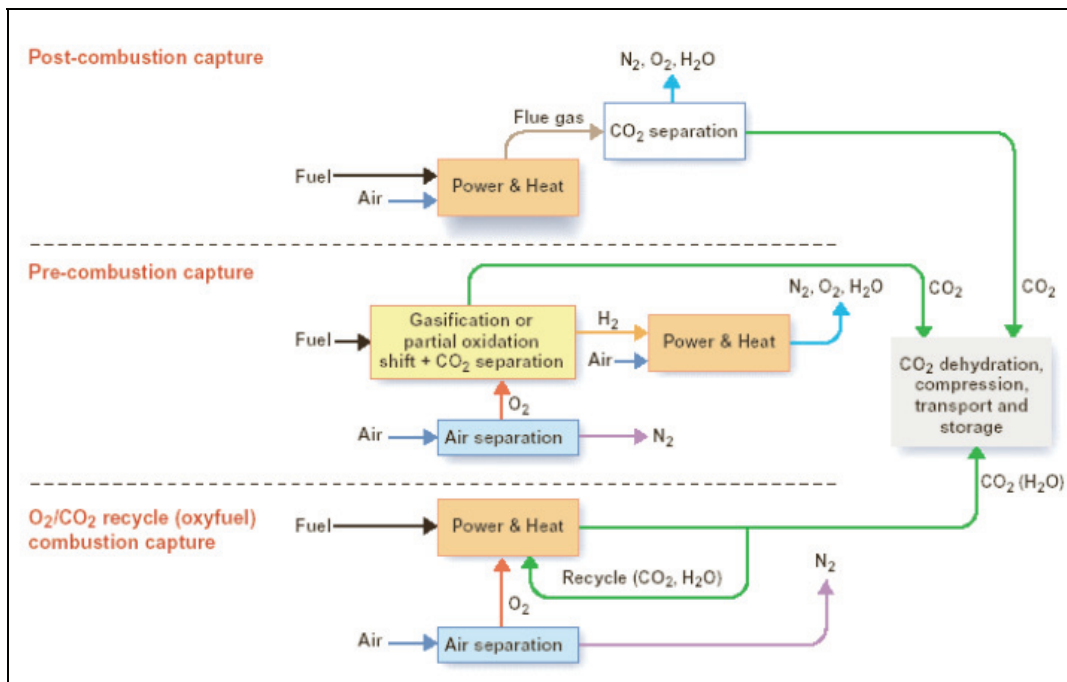

Fig. 9-1: The three basic options for CO₂ separation in power plants (Fig. 2.1 from [1])

All procedures have one thing in common, which is the fact that the CO₂ still needs to be dehydrated and compressed for transport after it has been concentrated. For a more detailed description of each individual process and all procedural steps involved, please see references [1] to [5]. The following is just a brief summary highlighting several important points.

2.1 Post-combustion capture

Post-combustion capture (see upper portion of Fig. 9-1) involves removing all CO₂ from the flue gas. Although the act of separating a gaseous element from the remaining flue gas is a tried and tested procedure in the context of environmental engineering (e.g. separation of SO₂ or NO_x during standard power plant operation), the separation of CO₂ results in a mass flow that is up to approximately two orders of magnitude higher. Several different separation principles based on absorption (chemical and physical), adsorption, liquefaction and also membrane filters are currently being explored. Of all these technologies, CO₂ capture in the form of chemical absorption in an aqueous amine solution is already commercially available on a small scale. Along with aqueous solutions made up of alkanolamines, such as monoethanolamine (MEA), diethanolamine (DEA) and methyldiethanolamine (MDEA), there are several commercially available absorbents, the main criterion being that they are sufficiently active to recover CO₂ at a relatively low concentration and atmospheric pressure.

Figure 9-2 presents the system diagram of a power plant with downstream separation of CO₂ from the flue gas. It should be noted that it is an advantage to install an additional upstream SO₂ scrubber, considering that SO_x forms an irreversible compound together with the MEA-based absorbents, a process which would in turn lead to a constant loss of absorbent material. The CO₂-laden, MEA-based absorbents, however, can be thermally regenerated – a

procedure that requires a process heat of approximately 3-4 GJ per ton of CO₂. This regeneration heat is extracted from the process steam at the outlet of the intermediate pressure turbine next to the intermediate superheating system, and results in a considerable loss of efficiency.

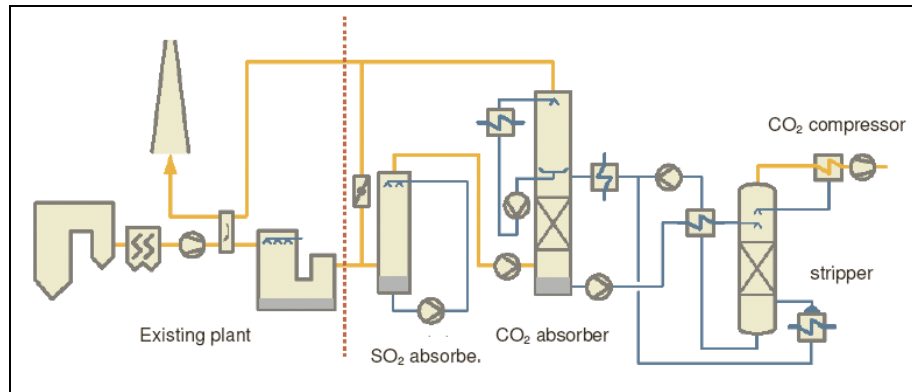
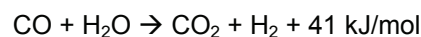

Fig. 9-2: System diagram of a power plant with SO₂ and CO₂ flue gas scrubbing, as well as steam bleeding to regenerate the solvent (Fig. 2.3 from [1])

The great advantage of post-combustion capture lies in the fact that, compared to the other procedures, it only marginally interferes with overall plant operation. This makes it the most suitable technology for upgrading existing power plants.

2.2 Pre-combustion capture

During pre-combustion capture (middle portion of Fig. 9-1), the coal fuel is first of all gasified (Integrated Gasification Combined Cycle (IGCC) power plant), and the CO produced in the process is then reformed by steam to generate H₂ and CO₂ gas.



This reaction has been known for a long time as a “water gas reaction” or “CO shift”. By means of physical absorption, the CO₂ can be removed from the fuel gas at a higher concentration (approx. 30 vol % of the total process gas) and under high pressure (20-30 bar). In future, it will also be possible to separate the hydrogen from this CO₂-H₂ mixture using membrane filters. The hydrogen is then fed into a gas turbine and the CO₂ is liquefied for transport to the repository. This entire procedure is illustrated in Fig. 9-3 [5].

There have only ever been very few coal-gasification demonstration power plants operating according to the IGCC concept. Due to poor availability and high investment costs, which are understandable considering the complexity of the process, a commercial breakthrough has not yet been achieved. The IGCC process would, however, be well suited to the purpose of CO₂ management, given that CO₂ capture at a higher concentration and under higher pressure always entails lower process costs and less energy consumption.

A similar process can also be carried out with natural gas, in which coal gasification is substituted by the reforming of CH₄ to generate synthesis gas, a mixture of H₂ and CO.

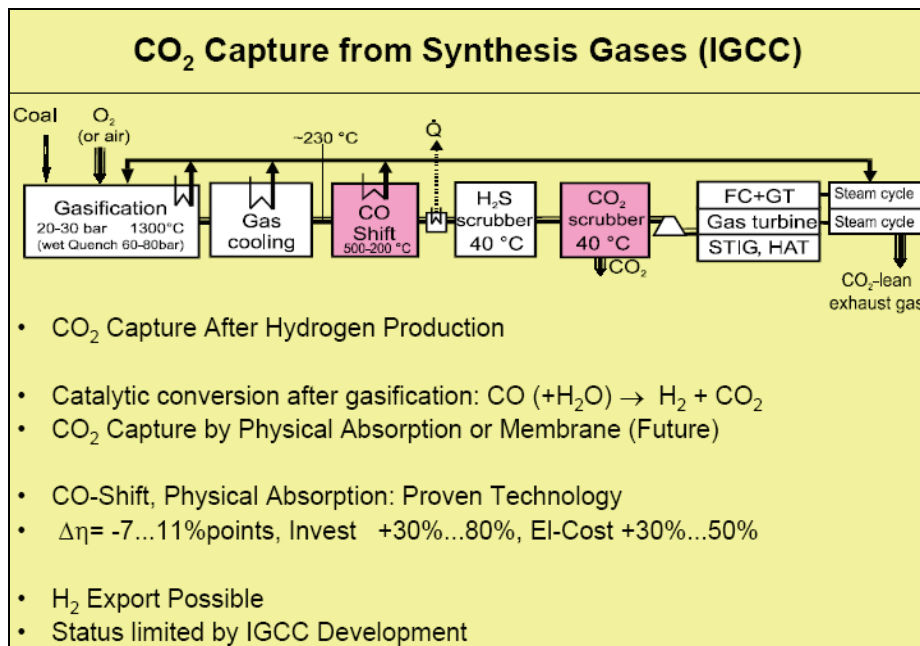

Fig. 9-3: CO₂ capture in fuel gas within a coal gasification power plant (slide from [5])

2.3 Oxy-fuel combustion

In oxy-fuel processes, nitrogen is removed from the combustion air. As combustion in pure oxygen would result in overly high combustion temperatures, a portion of the flue gas is channelled back in order to replace the atmospheric nitrogen. The out-flowing flue gas now consists almost exclusively of CO₂, the steam having been removed by condensation, and impurities such as SO_x, NO_x and dust having been filtered out. The diagram in Figure 9-4 illustrates an oxy-fuel, coal-fired plant of this type.

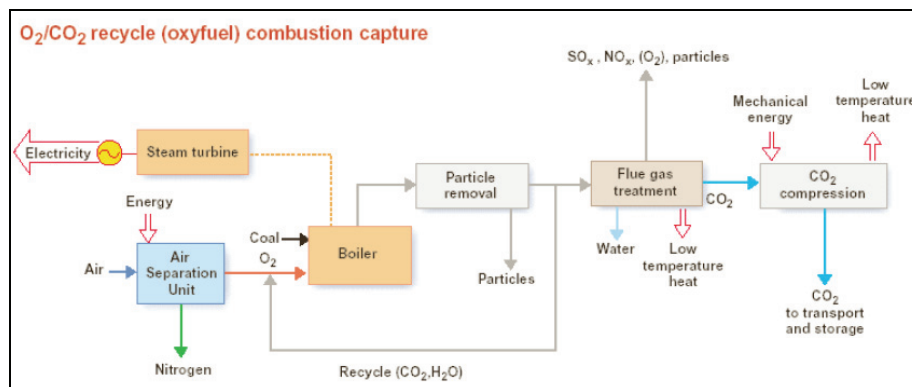

Fig. 9-4: Principle of combustion with O₂ and recycled CO₂, as applied to coal (Fig. 2.5 from [1])

The process of condensing air to provide oxygen is already being applied on an industrial scale in plants with an output of up to 5000 metric tons of O₂ per day, which corresponds to the consumption of a 300 MW_e coal-fired power plant. The problem with such plants, however, lies in the high level of energy consumption involved, ranging from approx. 250 to

270 kWh per metric ton of O₂, a level that continues to rise as purity requirements become ever more demanding.

2.4 Further processing and liquefaction of CO₂ for transport

In addition to the above-mentioned procedures for CO₂ capture, many other suggestions have been made as well, although these are far less developed. An overview of such ideas, many of which are very creative, can be found in the VGB Report [1].

For all processes, the gaseous CO₂ has to be conditioned for transport once it has been captured. As its critical point lies at approx. 31°C and 73 bar, the CO₂ is brought to the supercritical state and can then be transported in pipelines or tankers. This requires a considerable amount of energy, as is shown in the next section, and in itself results in a loss of 3 to 4 percentage points of the power plant's electrical efficiency.

2.5 Ideas relating to costs and electricity loss

It can generally be observed, on the basis of the previous sections, that

- on the one hand, there are processes that build on existing technologies, such as flue gas scrubbing with amines, which still need to be implemented on a large scale but are essentially in little need of further development, and
- on the other hand, there are numerous processes with more favourable prospects in terms of energy loss and investment costs, but which are still being developed or are even still in their research phase.

For many of the above-mentioned technical processes, the required technology is already commercially available, such that for implementation in the near future, it is possible to calculate the required level of energy consumption, as well as the effect this will have on electricity costs (the latter, however, with far less certainty). Along these lines, the VGB-Report [1] presents the following framework of relevant prices and efficiency losses:

- The electrical efficiency loss lies at **8-13 percentage points** in the case of coal-fired plants, and **9-12 percentage points** in the case of gas-fired plants. In both cases, these figures include 3-4 percentage points for CO₂ gas compression.
- The cost of power generation will rise by approx. 1-5 cents per kWh for the CO₂ capture including compression.

In short, it can be assumed that the described method for CO₂ capture is viable and that, if prices for CO₂ emission certificates continue to rise as is expected in the light of pollution-reduction targets, then this method will soon enter the realms of profitability. Moreover, in view of the many other technical solutions anticipated in the future, it can be expected that costs will continue to fall on a long-term basis and loss of electrical efficiency in power plants will be reduced.

3. Transport and storage

After capture, the CO₂ has to be compressed before being transported by ship or via a pipeline. This requires a considerable amount of energy, which in turn reduces the power plant's efficiency by 3-4 percentage points. Pipelines for CO₂ transport are already in use today, particularly in the USA, where transport costs are quoted at around 1-3 US\$ per metric ton of CO₂ per 100 km [6].

Extensive experience with large-scale CO₂ transport has also been gathered in the oil and gas industries, which use CO₂ in offshore repositories to increase oil production (Enhanced Oil Recovery: EOR).

The current possible uses of CO₂ would not be capable of absorbing the quantity accumulated during CO₂ sequestration. There are, however, a number of possibilities for long-term storage of carbon dioxide. Table 9-1 presents an overview and initial evaluation of global capacity for CO₂ storage, as based on an assessment given in [7].

	Global capacity [Gt CO ₂]	Safety	Technical hurdles	Rel. cost (€/t CO ₂)	Rating
Oil/gas reservoirs	100s	good	high	low: 5-10	++
Saline aquifers	100e-1000s	possibly good	medium	low: 15-20	+
Coal seams	10-100s	probably bad	low	low	°
Mine cavities	100s	good	high	high	-
Ocean dissolved CO ₂	1000s – 100000s	medium	medium	low: approx. 15	°
Deep-sea CO ₂ pools	1000s – 100000s	probably good	low	high: 60-80	-
Reforestation	10-100s	good	high	low: 5-20	+

Table 9-1: Global capacity for CO₂ storage (from [7]). For comparison: a total of approx. 25 Gt CO₂ are currently being produced each year from fossil fuels worldwide.

It can be deduced from Table 9-1 that there are two “huge” options for storage, these being: a) saline aquifers, with a global capacity for hundreds to thousands of gigatons of CO₂, and b) the disposal of CO₂ in the ocean, either as dissolved CO₂ or as a deep-sea pool.

However, based on what we know so far, ocean storage can by no means be considered an absolutely safe and unproblematic option at this point. There is also no experience base for this method as yet, unlike the industrial disposal of CO₂ in saline aquifers. The latter is already being practised by the Statoil company on a grand scale in the North Sea where, for many years, the large amount of CO₂ produced during natural gas recovery at the Sleipner field has been captured and injected on site into the so-called Utsira formation, which lies at a depth of approx. 1000 m beneath the seabed. The fate and movement of the injected CO₂ within this layer is being monitored in the context of a research programme.

Within Germany, there are also several possibilities for storing CO₂, either in depleted gas fields, saline aquifers or unmineable coal seams. Here, too, the greatest capacity by far lies in saline aquifers. Table 9-2 gives an overview of the various different storage opportunities in Germany.

Option	Storage capacity (Gt)	Permeability	Pore fluid	Overlying strata	Safety	CO ₂ for enhanced production	Conflicts of use
Gas fields	2.56	+	+	+	-	++	-
Aquifers	22.8 – 43.5		-	+	+		-
Coal seams	0.37 – 1.67	-	-	-	+	+	-
Oil fields	0.11		-	+	-	+	
Coal mines	0.78	+	++	-	--		--
Salt mines	0.04	++	++	++	--		--

Table 9-2: Overview of various storage possibilities in Germany and ratings thereof according to selected qualitative criteria ([6], Table 16)

According to the COORETEC study group, the estimated costs for transport and storage in Germany lie at around 10-24 € per metric ton of CO₂ [6]. For a modern coal-fired power plant, this means an additional cost of approx. 0.8-2 cents per kWh_{el}.

Altogether, it has been established that all CO₂ accumulated during fossil fuel combustion could in fact be stored directly in the relevant repositories without having to travel through the atmosphere. It must, of course, be taken into account that, due to the natural exchange between the atmosphere and the oceans, the CO₂ released from fossil fuels would in any case not remain in the atmosphere in the long run, but would finally be deposited to a large extent (approx. 85 %) in the ocean. However, owing to the long time-scale of ocean circulation and mixing of ocean sediments, this process would take many hundred to several thousand years. Direct storage in the ocean or in geological strata could therefore be regarded as a way of by-passing the carbon dioxide's natural route via the atmosphere. The extent to which this additional CO₂ may damage the ocean in the end is not yet known, although CO₂-related global changes in seawater (e.g. sinking pH value) can already be observed today [8]. For this reason, ocean storage of CO₂ is widely rejected as a matter of principle.

4. First pilot plants for CO₂ sequestration

The development of basic technical principles for CO₂ sequestration has made remarkable progress over the last few years. Now the aim is to plan and build several pilot plants in which to scale up the various different processes for CO₂ sequestration for large scale use, as well as to compare their advantages and disadvantages and to improve individual process steps.

Several energy groups have glimpsed an opportunity in this area and have recently launched their own activities. Here are just two examples: the Vattenfall group announced in May this year [9] that they intend to build the world's first CO₂-free lignite-fired pilot plant operating on the basis of the oxy-fuel process, and plan to commission it in 2008. This pilot plant, which is to be built in Germany at the Schwarze Pumpe site in Brandenburg, and which will have a thermal output of 30 MW, is meant to advance this new technology to commercial maturity. In late June in 2005, the BP oil company introduced their plans to build the world's first large industrial plant for the generation of CO₂-free electricity in Scotland [10]. The aim here is to transform natural gas into hydrogen and carbon dioxide. The hydrogen gas will then be used

to operate a 350 MW power plant, while the CO₂ will first be used to enhance oil production in the North Sea before being permanently stored there. After having completed initial feasibility studies, the company is now working on detailed design plans to verify the project's cost-effectiveness. The final decision to build the plant could well be made by the end of 2006, which would mean that it could be commissioned in the year 2009.

The implementation of these and similar projects ultimately depends on how current climate protection laws, and more particularly the trading of emission certificates, develop over the next few years. Experts [9, 11] anticipate that the building and operation of such power plants will start to become profitable for energy groups as soon as the price of CO₂ emission rights exceeds 20 euros per metric ton of released CO₂ (this value was already temporarily reached in 2005).

5. Evaluation of CO₂ sequestration

In terms of evaluating CO₂ capture and storage, the following can be observed:

- The prospect of CO₂ sequestration is raising high, well-founded hopes that this industrial process will prove to be technically and economically viable as well as ecologically acceptable, thus contributing significantly towards solving the CO₂ problem.
- Separating, transporting and storing the CO₂, however, requires approximately one quarter of the electricity produced by the original fuel. This means that, if all other circumstances remain unchanged, the potential yield of fossil fuels is reduced by one third.
- In view of the growing climate problem, CO₂ sequestration appears to be the only means of continuing to use existing fossil fuels in a climate-friendly way. It will allow us to buy a certain amount of time needed for the long-term transition to solar technology as well as the final move away from nuclear energy (also CO₂-free), considering that it does not currently seem possible to abandon nuclear energy while at the same time scaling down the use of fossil fuels.
- According to many, CO₂ sequestration has the potential to become one of the most cost-effective technologies in avoiding CO₂ emission. Considering the high industrial and political significance of CO₂ sequestration, it can be expected that the relevant industry will invest in researching and developing this process.

In conclusion, it can be said that CO₂ sequestration constitutes a highly important and promising option in the endeavour to reduce CO₂ emissions. However, because it will not come into use on a large scale until after 2020, it need not be taken into account when evaluating the energy and CO₂ saving potential for the purpose of this study.

Notes and references:

- [1] VGB Powertec, *CO₂ Capture and Storage*, VGB Report on the State of the Art, Essen 2004, available from VGB Powertec Service GmbH, Verlag Technisch-Wissenschaftliche Schriften, Postfach 103932, D-45039 Essen; available at <http://www.vgb.org>
- [2] Zevenhoven, R., Göttlicher, G. et. al., lecture (2003) at the TU Helsinki, *Greenhouse gas emission control and CO₂ long-term storage*; downloads of slides and texts: available at: http://eny.hut.fi/education/courses/Ene-47_200-2003/Downloads.htm
- [3] IPCC WG III, Workshop for Carbon Capture and Storage 2002, Proceedings, Regina, Canada, Nov. 2002; available at: http://arch.rivm.nl/env/int/ipcc/pages_media/ccs2002.html
- [4] IPCC WG III, *Special Report on CO₂ Capture and Storage*, Cambridge University Press, New York (2005), ISBN -13 978-0-521-68551-1; available at: http://arch.rivm.nl/env/int/ipcc/pages_media/SRCCS-final/IPCCSpecialReportonCarbondioxideCaptureandStorage.htm
- [5] Göttlicher, G., *CO₂ Capture From IGCC Power Plants* lecture (2003) at the TU Helsinki, see [2]; available directly as PowerPoint slides and script
- [6] Federal Minister for Economy and Labour, report by the COORETEC study group, *Forschungs- und Entwicklungskonzept für emissionsarme fossilbefeuerte Kraftwerke*, Berlin 2003, ISSN 0342-9288 (BMWA documentation no. 527); available at: <http://www.fz-juelich.de/ptj/projekte/datapool/page/1329/doku527.pdf>
- [7] Kranzmann, A., *Stromerzeugung ohne CO₂-Ausstoss in die Erdatmosphäre*, speech given at the 67th annual conference of the Deutsche Physikalische Gesellschaft, Berlin 2005; slides and conference transcript (2005) available at: http://www.uni-saarland.de/fak7/fze/AKE_Archiv/DPG2005-AKE_Berlin/Links_DPG2005.htm
- [8] Brewer, P., *Experiments on Ocean CO₂ Sequestration*, speech given at the 67th annual conference of the Deutsche Physikalische Gesellschaft, Berlin 2005; slides and conference transcript available at: http://www.uni-saarland.de/fak7/fze/AKE_Archiv/DPG2005-AKE_Berlin/Links_DPG2005.htm
- [9] Press conference held by the Vattenfall company on 26 May 2005; e.g. in: CHEMIE.DE Information Service GmbH, Berlin; <http://www.chemie.de/news/d/46247>
- [10] Press conference held by the BP company on 30 June 2005: "BP and Partners Plan Clean Energy Plant in Scotland, Increasing Oil Recovery and Reducing Emissions" available at: <http://www.bp.com/genericarticle.do?categoryId=2012968&contentId=7006999#top>
- [11] Strömberg, L., Vattenfall AB, Stockholm, *Fossil fuels without CO₂ emissions – technology and economy*, speech given at the autumn meeting of the DPG energy working group, Bad Honnef on 21 October, 2004; available at: http://www.uni-saarland.de/fak7/fze/AKE_Archiv/AKE2004H/Links_AKE2004H.htm

10 Solar thermal power plants in southern latitudes

1. State of the art

Solar thermal power plants concentrate direct solar radiation to a high intensity using various mirror configurations, heating up a suitable heat transfer fluid to a high temperature. This is known as concentrating solar power, or CSP for short. The heat energy gained is then channelled to conventional generating equipment such as steam or gas turbines, which convert it into electricity. There are basically three types of concentrating solar power plant, depending on the configuration of the focusing mirrors (see Fig. 10-1):

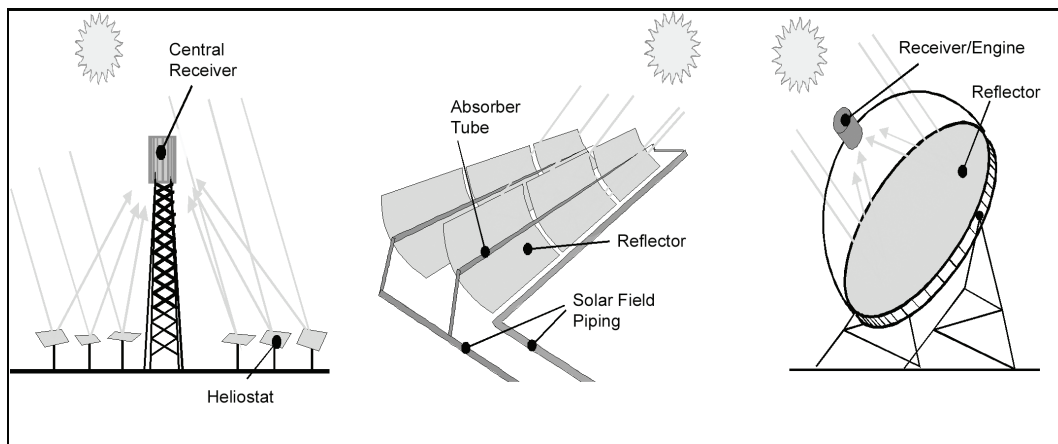

Fig. 10-1: Principles of solar concentration, from left: solar power tower, parabolic trough, parabolic dish (from [1])

The three main types are parabolic trough power plants, in which an absorber tube is positioned in the focal line of a trough-shaped parabolic mirror, and parabolic dish and solar tower power plants, in which a more or less punctiform receiver is located at the focal point of a parabolic mirror. The two latter configurations differ only in the size of the available reflector surface: parabolic dishes use a single mirror of up to 10 metres in diameter, and have a correspondingly limited output. In heliostat power plants (power towers), by contrast, the sun's rays are focussed on a central heat exchanger at the top of a tower by an array of steerable mirrors (heliostats) that track the position of the sun. All three technologies have been extensively tested. Solar updraft towers, a fourth option not yet in operation, will not be discussed in this report.

Since it is only direct sunlight that can be concentrated with these optical elements, solar thermal power plants can only operate in locations with a high abundance of direct solar radiation. The most suitable sites are those in the Earth's sunbelt region close to the equator, at geographical latitudes up to about 30-40° north or south (which includes places such as southern Spain, at a latitude of 37°), where there are 2000-2600 hours of sunshine per year (1 year = 8760 hours). Solar power plants in these regions have good prospects of becoming economically viable in the medium term [2]. To facilitate their commercialisation, it could be helpful to begin by using hybrid power plants in which steam is produced by a combination of solar energy and fossil fuels. In the

longer term, however, it will be necessary to develop cost-efficient thermal energy reservoirs so that the power plants can be operated without auxiliary power from fossil sources even when the sun is not shining.

Parabolic trough power plants

Parabolic trough power plants (Table 10-1, columns 4 and 5) are the type of power plant that has undergone the most extensive testing and the only type that is already in commercial use. They consist of trough-shaped reflectors up to 100 metres long that focus the sunlight on an absorber tube. The tube contains a heat transfer fluid, a synthetic oil, which becomes hot and transfers the heat to the steam turbine. Since the heat transfer fluid limits the maximum operating temperature to 400°C, the solar energy at these plants can only be fed into steam turbines. Alternatively, the heat transfer medium can be water vapour, which allows temperatures up to 500°C.

	Solar tower	Solar tower (REFOS)	Parabolic trough	Parabolic trough	Parabolic dish
Output (solar) MWel	5-200	5-200	5-200	5-200	0.01-0.1
Application	Steam turbine, ISCCS	Gas turbine, CC power plant	Steam turbine, ISCCS	Steam turbine, ISCCS	Gas turbine, Stirling motor
Receiver/absorber	Tube assembly or non-pressurised volumetric receiver	Volumetric receiver	Absorber tube	High-pressure absorber tube	Tube assembly or heat pipe
Heat transfer medium	Air, salt, steam	Air	Thermal fluid	Steam	Air, helium, hydrogen
Peak efficiency %	18-23	approx. 30	18-21	20-23	20-29
Average efficiency %	14-19	approx. 25	10-15	14-18	16-23
Operating temperature °C	600-800	800-1200	300-400	400-500	900-1200
Operating pressure bar	<5	15-20	<5	100-120	<15
Status	Demonstration	Demonstration	Commercial	R&D	Demonstration

(CC: Combined-cycle gas and steam turbine power plant, REFOS: solar receiver for fossil gas turbines and combined-cycle facilities, ISCCS: Integrated solar and combined-cycle system)

Table 10-1: Examples of the CSP technologies listed above (from [3])

Since the mid-1980s, nine parabolic trough power plants known as SEGS (solar energy generating systems) (Table 10-1, column 4) with an overall electricity output of 354 MW (nominal output of the individual modules ranging from 14 to 80 MW) have been in commercial operation in California, USA. On an annual average, the power plants operate with a solar electric peak efficiency of 21% (using 75% solar energy and 25% natural gas as a back-up). The maximum useful output for each power plant module is estimated at approximately 200 MWel. For values larger than this, the distance between the turbine and the collectors would be too great.

These power plants have proved extremely satisfactory in operation and form the basis of projects being planned today in southern Europe and in developing countries close to the equator. In Spain, for instance, a parabolic trough power plant with a nominal output of 50 MWel

(capital cost €200 million) is at the planning stage [2,4]. Part of the collected solar energy can be stored in a thermal energy reservoir with a 9-hour peak load capacity ensuring that the power plant continues to generate electricity even after sunset. The whole concept is tailored to the conditions in Spain, and is designed to achieve a similar initial electricity production cost (roughly 14-18 cents per kWh) to that determined for the power plant in California today, even though Spain has 20% less direct sunlight than California.

Parabolic dish power plants

Parabolic dish power plants (Table 10-1, column 6) are free-standing facilities with an electricity output of between 10 and 100 kW (depending on the size of the reflector surface). Achieving a very high operating temperature of 900-1200°C, they produce the highest solar electric efficiency rates so far (peak efficiency 20-29%) [5]. The energy is typically converted with Stirling engines (dish/Stirling systems) or Brayton gas turbines (dish/Brayton systems) placed directly at the focal point of the parabolic mirror together with the absorber. These parabolic dish facilities are now technically mature, but have not yet achieved a breakthrough on the market.

Solar tower power-plants

In the conventional solar tower concept (Table 10-1, columns 2 and 3), a heat transfer medium (air, salt, water vapour) is heated to 600-800°C in a tube assembly or a porous matrix (non-pressurised volumetric receiver) exposed to concentrated solar radiation. The solar heat is converted into electricity by a steam generator and a steam turbine, achieving peak efficiency rates of 18-23%. Several demonstration projects involving solar power tower technology have been implemented with great success in the USA (tube assembly receivers; molten salt as the heat transfer and storage medium) and in Spain (volumetric receivers; air as the heat transfer medium).

2. Potential for medium-term technical progress

The most effective way to cut the electricity costs of solar thermal power plants is by increasing their overall efficiency. Concentrating solar systems can theoretically reach significantly higher output than are actually realised at the present time, and higher temperatures would in turn lead to higher efficiency rates in the steam turbines further downstream. For example, parabolic trough collectors could achieve temperatures up to 550°C and thus optimally power a conventional steam power plant. Thermal fluid, the synthetic oil used as a heat transfer medium in today's commercial systems, limits the temperatures to a maximum of 400°C. Significantly higher operating temperatures can be achieved [6] by producing steam directly in the parabolic trough collectors [6] (see Table 10-1, column 5). A demonstration plant has been in operation since 1999 at the Plataforma Solar de Almería, Spain.

Concerning solar tower technology, special emphasis is given to a new concept with closed volumetric receivers (REFOS concept [7]; see Table 10-1, column 3) which make it possible to heat up the air under pressure (15-20 bar) and thus achieve operating temperatures of 800-1200°C. This would also enable the concentrated solar energy to be fed into highly efficient gas-turbine and combined-cycle power plants. This solar air heating technology has been developed in Europe and can be used for a broad capacity range of approximately 5-200 MWeI.

The other main means of cutting the cost of solar power is by developing thermal energy reservoirs with a long service life and low specific costs. Energy reservoirs increase the proportion of solar energy at the power plants, improve operational behaviour and permit a higher utilisation rate of the power plant block. The development of thermal reservoirs was neglected in Europe at first, hybrid plants using auxiliary power from fossil fuels being preferred as a more cost-effective option in the short term. Various energy reservoir concepts with innovative storage materials have been proposed and successfully tested in the last few years. The DLR, for example, has tested a concept using high-temperature concrete as a storage medium for parabolic trough collectors with temperatures up to 400°C, and a concept using silica sand as a storage medium for tower power plants with temperatures up to 900°C [4].

3. Costs and potential savings

The commercially available technology is at present based on parabolic trough collectors using thermal fluid and on heliostat power plants with an atmospheric air receiver, both of which drive a steam cycle. Whilst the initial cost of solar power is still of the order of 18 cents per kWh (14 cents per kWh for hybrid operation) at the parabolic trough power plants already in operation in California (SEGS II-VII; Table 10-2, column 3), it would be possible by constructing new, larger units producing 100 MW in favourable locations (SEGS new; Table 10-2, column 4) to achieve electricity costs of roughly 9 cents per kWh for purely solar operation and roughly 6 cents per kWh for hybrid operation (using 50% auxiliary fuels) [3]. The costs of power towers (Table 10-2, column 5) are a little higher because they are still at a more rudimentary stage of development.

		SEGS II-VII	New SEGS	Solar tower	ISCCS	Dish/Stirling
Output	MW	30	100	30	150	0.01
Specific investment costs	€/kWeI	3,450	1,900	2,700	1,700	6,350
Solar operation						
Hours at full load	h/a	2,100	2,250	2,250	450	2,250
Electricity costs	ct/kWh	17.8	9.2	13.0	–	30.6
Hybrid operation						
Hours at full load	h/a	2,800	4,500	4,500	6,750	4,500
Fuel consumption	MWh/a	60,000	643,000	193,000	2,100,000	64
Proportion of solar energy	%	75	50	50	50	50
Electricity costs	ct/kWh	14.1	6.0	7.9	7.9	16.7

Table 10-2: Investment and operating costs of solar thermal power plants in regions with high solar radiation (direct radiation 2,350 kWh/m²a) for existing SEGS facilities and projected new plants (fossil fuel efficiency 35%; ISCCS efficiency 45%) (from [3])

Because so few solar thermal power plants have yet been built, it is difficult to extrapolate any reliable learning curve (correlation between costs and accumulated production output). Based on plausible learning factors, the authors of [3] estimate that the cost of electricity from solar thermal power plants should drop to 52% of the level in 2000 between now and 2020, and to 39% by the year 2050. Adopting a different basis for calculation, the same authors used the results of the BMU-funded SOKRATES study [8] and its forecasts up to 2025. They extended this scenario up to 2050 and reach the conclusion [3] that the specific investment costs of solar thermal power plants are even likely to drop to about 30% by 2050.

Figure 10-2 shows the anticipated evolution of the electricity generating costs associated with concentrating solar thermal power plants in various locations with different degrees of solar radiation and for different operating modes [9]. Note, however, that the forecasted progressive lowering of costs assumes that the commercialisation of solar thermal power plants in the next 10-20 years will evolve in approximately the manner described in the SOKRATES auxiliary power scenario [8].

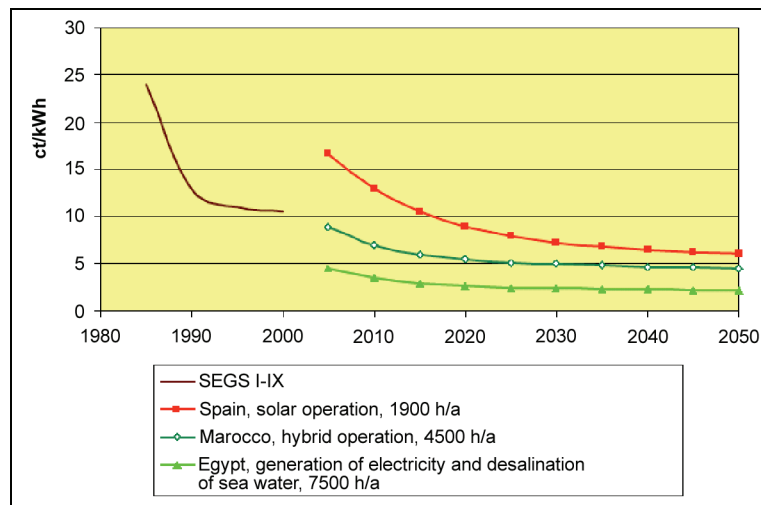

Fig. 10-2: Anticipated electricity generating costs associated with concentrating solar thermal power plants under various conditions (from [3])

Approximately half of the anticipated drop in costs is accounted for by scaling up to larger units and by the lower price of larger output quantities, while the other half is due to R&D efforts on the technological side [10].

4. Solar power from North Africa for Europe/Germany

A promising first step would be to make solar energy available to the populations actually living in the Earth's sunbelt near the equator (North Africa, the Middle East and Central America). The process heat generated concurrently with the solar power could then be used for desalination of sea water to meet the growing demand for drinking water. Given that the people living in these

regions themselves account for approximately 15% of the world's energy requirements, this in itself would go a long way towards protecting the global climate.

The calculated potential electricity yield of solar thermal power plants in the regions close to the equator is tremendous, far exceeding local demand. In North Africa, for example, it amounts to about 200-300 GWh_{el} per square kilometre per annum. In other words, Germany's entire electricity demand could be satisfied with a built-over surface area of 45 x 45 km² (equivalent to 0.03% of all suitable areas in North Africa). The next step in this direction must therefore be to set up an efficient electricity network between North Africa and Europe. This can be achieved with high-voltage DC (HVDC) transmission lines of the type already in operation for transmitting electricity over distances up to several thousand kilometres [11].

At today's prices, it would cost approximately €2.5 billion to build a high-voltage DC transmission line of the kind that such an electricity network would require, with a capacity of 2,000 MW and covering a distance of 3,000 km. This means that it would cost 1.5 to 2 cents per kWh to transfer solar power from North Africa to Central Europe [3]. Assuming a dynamic market introduction of solar thermal power plants, from about 2015 onwards, it should be possible to attain a price level of about 10 cents per kWh for imported solar electricity in Germany. This level should ultimately drop to about 5.5 cents per kWh [3].

5. Conclusions and plea for action

After being successfully launched in California in the 1980s, solar thermal power technology must today be given a fresh opportunity to enter the markets in the Earth's sunbelt regions. One wonders why this development has taken so long to mature, even though both the final report published in 1995 by the 12th German parliament's committee of inquiry into the protection of Earth's atmosphere [12] and the 'Energy Memorandum 1995' published by the DPG [13] explained the need for solar thermal power plants in the Earth's equatorial sunbelt and called for their timely development.

To begin with, these are major projects involving high investment costs and a correspondingly high financial risk which would have to be cushioned by State guarantees in view of the urgency of the climate problem. Moreover, the facilities would have to be built at the southernmost tip of Europe or in North Africa, which calls for the appropriate international contacts on the part of the electricity distributors – and possibly even at government level – for constructing them and for providing the necessary transit arrangements. The hesitant attitude of the energy industry and the appropriate government bodies may perhaps be explained by the initial optimism of the 1990s in Germany, when we were confident of being able to cope with the CO₂ problem at home. However, the extremely slow rate at which CO₂ emissions are being reduced, as demonstrated once again in this study, should be proof enough that we urgently need to import solar power. Although a number of solar thermal projects exist at the planning stage in various parts of the world, their implementation has been postponed year after year despite promised financial support from the World Bank (Global Environmental Facility).

Meanwhile, in 2002 – with the support of interested industrial partners – research establishments around the world engaged in the development of solar thermal power plant technology (in Germany this is primarily the DLR) have closed ranks to form the ‘Global Market Initiative for Concentrating Solar Power (GMI-CSP)’ [14]. By pooling the efforts of its members, this initiative aims to create a propitious climate for the global implementation of projects for generating solar thermal power. The goal that the initiative has set itself between now and 2015 is to install solar thermal power facilities with an overall output of 5,000 MW, to make this technology competitive on the global market, and to provide the necessary funding.

It can be seen as a certain degree of progress that in 2003, by passing an electricity feed law with generous price guarantees, Spain created the essential conditions for the construction of three solar thermal pilot plants (PS 10, ANDASOL and SOLAR TRES), which will represent an important first step on the road towards creating a commercial market for solar thermal power.

These projects receive financial support from the EU, as does an initiative entitled ECOSTAR [15] aimed at focussing European R&D activities on the goal of bringing down the cost of solar thermal electricity from 15-20 cents per kWh to 5-7 cents per kWh within the next 10 to 15 years.

Notes and references

- [1] Eisenbeiß G. and M. Geyer, *Solarenergie aus dem Sonnengürtel*, in: *Moderne Wege der Energieversorgung*, ed. W. Blum, Deutsche Physikalische Gesellschaft – Arbeitskreis Energie (11 Vorträge der Leipziger Tagung, 2002), 5-19; available from: http://www.uni-saarland.de/fak7/fze/AKE_Archiv/DPG-VVE_VortragsVerzeichnis-Energie.htm
- [2] Eisenbeiß G. and R. Pitz-Paal, *Solare Kraftwerke*, Jahrestagung des Forschungsverbunds Sonnenenergie 2002, Stuttgart, 4-12; available from: <http://www.fv-sonnenenergie.de/Publikationen/index.html>
- [3] *Umweltpolitik: Ökologisch optimierter Ausbau der Nutzung erneuerbarer Energien in Deutschland*, published by BMU, content edited by DLR, ifeu, Wuppertal Institut, April 2004, 285 pages; available from: <http://www.erneuerbare-energien.de/inhalt/5650/20049/>
- [4] Pitz-Paal R., *Ziele bei der Entwicklung von Solarthermischen Kraftwerken*, in: *Optionen für die Energie der Zukunft*, ed. M. Keilhacker, Deutsche Physikalische Gesellschaft – Arbeitskreis Energie (11 Vorträge der Tagung Hannover, 2003), 17-33; available from: http://www.uni-saarland.de/fak7/fze/AKE_Archiv/DPG2003-AKE_Hannover/Links_DPG2003-AKE_Vortraege.htm
- [5] Schlaich, Bergemann and partners: *Dish-Stirling Systems for Decentralised Power Generation*, pamphlet, Stuttgart 2000; available from: <http://www.sbp.de/en/fla/mittig.html>
- [6] Price H. et al., *Advances in Parabolic Trough Solar Power Technology*, Journal of Solar Energy Engineering 124 (2003?) 109-125
- [7] Buck R. et al., *Solar-Hybrid Gas Turbine-Based Power Tower Systems (REFOS)*, Journal of Solar Energy Engineering 124 (2002?) 2-9
- [8] *SOKRATES – Solarthermische Kraftwerke zum Schutz des Erdklimas*. BMU research project, interim report, DLR, Stuttgart 2003

- [9] Trieb F. and H. Müller-Steinhagen, *Combined Solar Power and Water for the Development of Arid Regions*, Proc. of EUROMED 2004, May 2004 (to be published)
- [10] Sargent & Lundy, *Assessment of Parabolic Trough and Power Solar Technology Cost and Performance Forecasts*, SL-5641, Chicago, USA, May 2003
- [11] Trieb F. et al., *Potentiale, Standortanalysen, Stromtransport*, as in [2], 36-43
- [12] Committee of inquiry into *Schutz der Erdatmosphäre* on behalf of the 12th German parliament: Final report *Mehr Zukunft für die Erde*, Economica-Verlag, Bonn, 1995, 1540 pages
- [13] *Energiememorandum 1995 der DPG*, 21 March 1995 (published in: Phys. Bl. **51**, 388 (1995))
- [14] *The Palm Springs Protocol for a Concentrating Solar Power Global Market Initiative*, 2nd International Executive CSP Conference in Palm Springs, California, October 2003
- [15] Roadmap Document SES6-CT-2003-502578, *European Concentrated Solar Thermal Road-Mapping*, edited by R. Pitz-Paal et al., DLR, 16.2.2005

11 Final appraisal and plea for action

1. Summary of conclusions so far

In Chapter 1 of this study, we reviewed the emissions situation over the past 15 years. After eliminating effects that can be directly ascribed to the consequences of German reunification (which account for a reduction of around 7%), the results showed a steady decrease in CO₂ emissions of 0.6% p.a. and of 4.3% p.a. for CH₄ and roughly 3.4% p.a. for N₂O. If we assume that the same circumstances will prevail through to 2020, a continuation of this trend would result in total greenhouse gas emissions of

871 million metric tons CO₂ equivalent p.a.

by the year 2020 (see Fig. 1-5).

After discussing (in Chapter 2) the possible ways in which energy consumption might be reduced, which are many and of theoretically high potential, but none of which seem to be capable of producing savings on a scale that surpasses the existing trend, Chapters 3 to 10 go on to deal with the supply of consumer energy. Each chapter describes one of the eight main forms of power generation being considered on the supply side as a possible means of modifying the present trend. Two of these stand out in the sense that they cannot be expected to contribute any trend-modifying factors between now and 2020, given that they will not be able to produce electricity in sufficiently high quantities before that date: *Fossil-fired power plants with CO₂ sequestration* and *Solar thermal power plants in southern latitudes*. That leaves six which can be assessed to determine the possible impact of (a) increasing the use of renewable energy sources, (b) renewal of the power plant stock in the electricity generating sector and (c) the possible abandonment of nuclear power. Finally, a trend-modifying factor can be found in (d) the road transport sector, in connection with the introduction of alternative fuels.

(a) CO₂-free generation of electricity using renewable energy sources

Renewable energy source	Contribution in 2020 (TWh)
Wind	76
Hydropower	23
Other	5 – 20
Total	104 – 119

Table 11-1: Estimate of the amount of electricity generated from renewable sources in 2020

At the present time, wind energy counts as the most important renewable energy source. In Chapter 5, we argue that production can be expected to reach 76 TWh/a by 2020, *on condition* that the plans indicated as achievable by 2015 in the dena grid study have been implemented by 2020. This result is nevertheless dependent on overcoming the difficulties mentioned in Chapter 5, especially those related to the financial aspects after 2010. The second most important renewable energy source today is hydropower, which has been

producing a constant output of around 20 TWh/a for many decades. At this point in our assessment we estimate a figure of between 5 and 20 TWh/a for the sum of all other renewable sources of energy (photovoltaics, biomass, geothermal energy etc., see Chapters 4 and 6).

Other studies have also attempted to estimate the probable electricity generating capacity from renewable energy sources in 2020. Some of their results are listed in Table 11-2, which also groups these estimates together to form a single range.

Study	Estimated figure (TWh)	Source
Prognos, EWI	111	[3a]
DIW Berlin, Politikszenerien I	99	[2]
Model scenarios developed by Jülich using IKARUS	89 – 108	[3]
Own estimate	104 – 119	Table 11-1
Combined estimate, used in this study	89 – 119	

Table 11-2: Various estimates (including by other authors) of the share of electricity generating capacity achievable using renewable energy sources by 2020, and the combined range covering all of these estimates

The upper limit of this range coincides more or less with the target envisaged by the German government [4], namely to generate 20% of the country's electricity needs, which would correspond to about 120 TWh, using renewable energy sources. The estimates presented as graphs in the appraisal compiled by Nitsch et al. [5] likewise fit into the same range.

A recently published statistical overview of all renewable energy sources [4a] enables us to look at the entire range of renewables employed to generate electricity, rather than counting up the individual contributions, and to compare this figure with the above estimates.

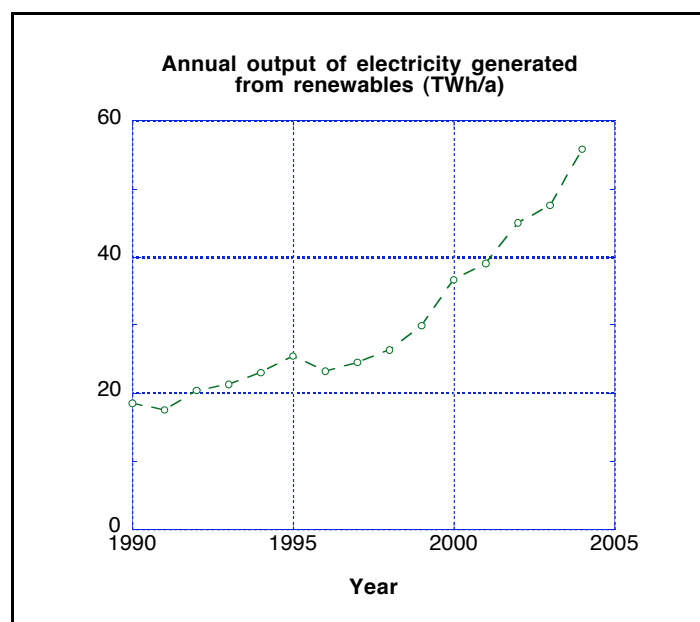

Fig. 11-1: Progression over time of annual electricity production from the sum of all renewable energy sources

In 2004, the share of the electricity supply generated from all renewable sources stood at 55.8 TWh. Of this output, 37.1 TWh was subsidised by payments under the Renewable Energy Sources Act amounting to €3.39 billion [4b]. The year-by-year progression of this output is plotted in Fig. 11-1. At the beginning of the 30-year period being investigated in this study, electricity generated from renewable fuel sources was almost exclusively hydro-power, and the production of 18.5 TWh/a was only one third of today's level. Output rose only slowly over the first few years, before accelerating later. The production of electricity from renewable sources has increased by an annual average of 3.3 TWh/a over the past ten years, or at the slightly lower average rate of 2.7 TWh/a since 1990. The rate at which electricity from renewable sources has risen over the last ten or 14 years respectively can be regarded as the trend. If the trend continues in the same way, electricity from renewable sources will increase by a further 52.5 or 42.7 TWh/a by 2020 to attain a figure of 108 or 98.5 TWh/a.

(b) Renewal of the power plant stock in the electricity generating sector

The most modern power plant stock in 2020 will have a CO₂ efficiency far superior to that of today, and will furthermore benefit from a higher proportion of natural gas in the mix of fossil fuels, see tables in Chapter 3 and the summarised conclusions in Table 11-3 below. These figures are based on the assumption that the (least efficient) half of the power plant stock will be progressively improved through the introduction of the latest technology between now and 2020. If we similarly assume that the proportion of natural gas will be doubled to 32% [1], then each kilowatt-hour of electricity produced in 2020 will on average only generate 700 grams of CO₂ as opposed to 858 grams in 2003.

Gas/fossil ratio	CO ₂ efficiency g CO ₂ /kWh
0.25	725.5
0.32	699.5
0.40	662.5

Table 11-3: CO₂ efficiency of a modernised power plant stock in 2020 as a function of the share of natural gas

(c) Increased CO₂ emissions due to the shutdown and substitution of nuclear power plants

At present, an average of 168 TWh of electricity is produced annually by nuclear power plants in Germany. If this generating capacity were to be shut down by 2020, the equivalent amount of electricity would have to be provided by renewables and fossil-fired power plants. Despite modernisation of the existing power plant stock and a doubling of the proportion of natural gas (to 32%), this would result in the emission of an additional 117.5 million metric tons of CO₂ into the atmosphere each year [6]. If the proportion of natural gas were to be increased even further in the course of adding capacity to replace nuclear plants – a figure of 40% is not inconceivable – then the associated CO₂ emissions would be slightly lower, at 111.7 Mt CO₂/a (see Table 11-3). This latter conservative figure is used in the following.

(d) Reduced CO₂ emissions in the road transport sector through the introduction of alternative fuels

In Chapter 7, the use of alternative fuels is estimated to bring about a 10% reduction in CO₂ emissions by road traffic in 2020. This corresponds to 20 million metric tons of CO₂ p.a.

2. Assessment of possible reductions over and above the trend

(a) Electricity from renewable energy sources

Here we need to isolate the part of electricity production that lies above the trend. Our calculation takes into account the sum of all renewable sources and is based on the German government's target of 120 TWh, a figure at the upper end of our estimated range (Table 11-1). From this target value for 2020 we subtract the value that would result in 2020 if the trend were to continue onwards from the past development at an even rate. This was estimated earlier to be either 108 or 98.5 TWh/a, depending on the length of the reference period.

The result shows that the target value exceeds the trend by between 12 and 22 TWh/a. This corresponds to **8 to 15 Mt CO₂ p.a.** [6a], which can only be regarded as a saving if at the same time it replaces electricity that would otherwise be produced in fossil-fired power plants.

Target value for electricity production 2020 (German government)	120
minus actual electricity production in 2004	55.8
minus the increase predicted by the trend: 16 years x (3.3 or 2.7 TWh/a ²)	52.5 or 42.7
CO₂-free electricity from renewable sources in excess of the predicted trend (rounded)	12 - 22

Table 11-4: Calculation of the annual production of CO₂-free electricity in 2020 in excess of the extrapolated trend (in TWh/a)

(b) Power plant stock

Improvements made between 1992 and 2003 reduced CO₂ emissions per kilowatt-hour by a factor of 0.920 (Table 3-2); similar improvements continuing through to 2020 (i.e. extrapolation of the trend) would result in a factor of 0.879 for the period 2003 to 2020 (see Table 3-2). But in fact the anticipated reductions in specific CO₂ emissions are higher than those predicted by the trend, and represent a factor of 0.927 (Table 3-3). Consequently, an additional saving of 7.3% of CO₂ emissions from fossil-fired power plants can be expected, which corresponds to approximately **23 Mt CO₂ p.a.**

(c) Nuclear power stations

The increase in CO₂ emissions associated with the withdrawal of nuclear power (**111.7 Mt p.a.**) is an additional burden totally outside the trend, given that the past value for 1990-

2004 used to calculate the trend covers a period when the nuclear generating capacity was in operation.

(d) Road transport

Here, the part lying above the trend can be attributed to the introduction of alternative fuels. Its impact only became effective in the second half of the 30-year period covered by our study, where it amounts to roughly **20 Mt CO₂ p.a.** We have not made any allowance for ongoing improvements in engine efficiency leading to lower fuel consumption because the downward trend in fuel consumption observed in the past can be expected to continue at a similar rate over the next 15 years, as discussed in Chapter 7.

Summary of trend-modifying factors

Trend-modifying factor	Change in CO ₂ emissions (Mt CO ₂ /a)
Additional renewable energy sources, at a rate exceeding present growth	– (8 to 15)
Renewal of the present fossil generating capacity and twofold increase in the proportion of natural gas to 32%	–23
Introduction of alternative fuels for road transport	–20
Closure of nuclear power plants and substitution by modernised fossil-fuel plants 2020; natural gas 40%	+ 111.7
Overall impact if nuclear power is shut down	+ (54 to 61) increase
Overall impact if nuclear power is retained	– (51 to 58) decrease

Table 11-5: Summary of decreases/increases in CO₂ emissions deviating from the trend

The extrapolated value of 871 million metric tons CO₂ equivalent in 2020 must be modified by the figure shown in bold type in the bottom two lines of the table. For the purposes of this study, greenhouse gas emissions in Germany can be expected to reach a level in 2020 that lies between

813 and 820 million metric tons CO₂ equivalent if nuclear power is retained

or

925 and 932 million metric tons CO₂ equivalent if nuclear power is shut down.

This is the principal conclusion of our analysis, illustrated in Fig. 11-2, which is the graphical counterpart to Table 11-5. It shows three alternative values for greenhouse gas emissions, expressed in terms of million metric tons p.a. measured CO₂ equivalent. The left axis marks the trend level of 871 Mt/a, the best estimate of the result achieved if past efforts are continued at the same rate in the future. The middle axis represents the lower value that would be achieved if the trend-modifying factors shown in lines 1-3 of Table 11-5 were added (813 to 820 Mt/a). Finally, the right axis represents the value that would be achieved if, in addition to these factors, nuclear power were to be shut down (925 to 932 Mt/a).

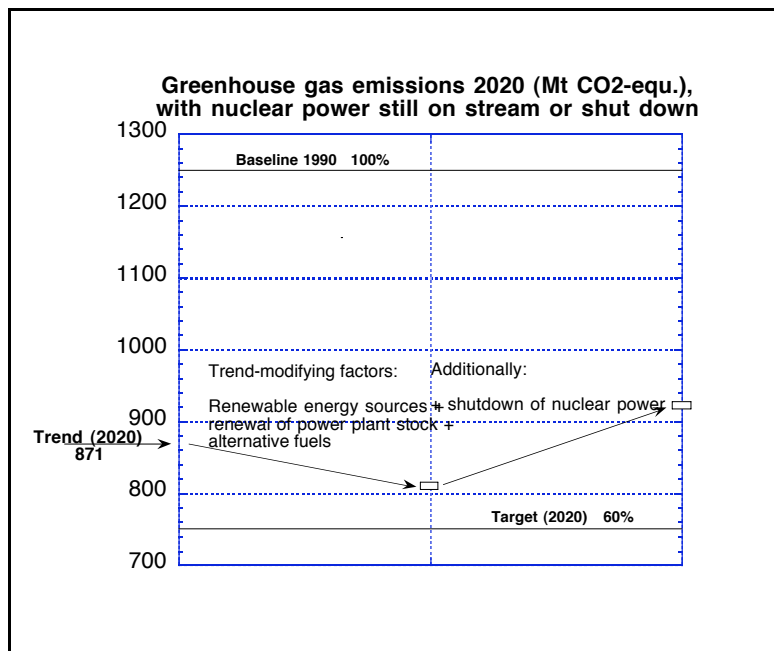

Fig. 11-2: Graphical representation of the data in Table 11-5. The trend-modifying factors are shown separately. See text.

Like any other attempt to predict the future, our estimates are bound to be incomplete. This is partly because we have been obliged to work with statistical figures for events that will not necessarily happen in the way we assume, an uncertainty which is particularly relevant in the case of renewable energy sources, where we have assumed optimistic values for their evolution. Another inaccuracy stems from the fact that certain options for reducing CO₂ emissions have been omitted from our analysis, because we do not expect them to make any noticeable contribution in the next 15 years on the basis of the trend observed for the past 15 years. In certain areas this could lead to surprises – either positive or negative. Given the present high price of crude oil, it is conceivable that car buyers, drivers and house owners might be persuaded to adopt a universal pattern of behaviour that gives greater emphasis to energy saving. But to have a significant impact on the results of our analysis, such changes in attitude would have to propagate to the scale of a very large mass movement.

3. Overall assessment

Even in the best case (where nuclear power plants are kept in operation and the expansion of renewable energy sources is pursued to its maximum effect), the result would fall short of the envisaged target of “40% lower emissions by 2020” by 60 Mt CO₂ equivalent. And if Germany should pull out of nuclear power altogether, the result of 30 years of “climate protection” would amount to no more than a 26% reduction with respect to the baseline year 1990.

The failure to meet even the first important target of cutting annual CO₂ emissions by 25% between 1990 and 2005 (see Fig. 1-1) is a fact that should not be swept under the carpet. On the contrary, it might help us to understand the time scale of the reduction mechanisms.

From where we stand today, we need to realise that consumers have indeed embraced the government's incentives to reduce CO₂ emissions, but not as quickly as originally imagined. The 21st century's major challenge of finding solutions to global warming has to overcome a greater inertia than was hoped for at the outset, even within the national context – the inertia existing on an international level, by contrast, has always been evident. Modern industrial society is based on the freedom of its citizens to make their own decisions, and it is rarely possible to enforce punitive compulsory measures – at least not if the ruling government hopes to be re-elected.

The situation is no different in the United Kingdom, which can be readily compared with Germany and where the government, too, has displayed its commitment to taking steps to deal with the issue of climate change. The decrease in annual CO₂ emissions [7] has been just as slow as it has in Germany, as can be seen in Fig. 11-3. Here too, the national target of reducing CO₂ output by 20% by 2010 [8] is unlikely to be met.

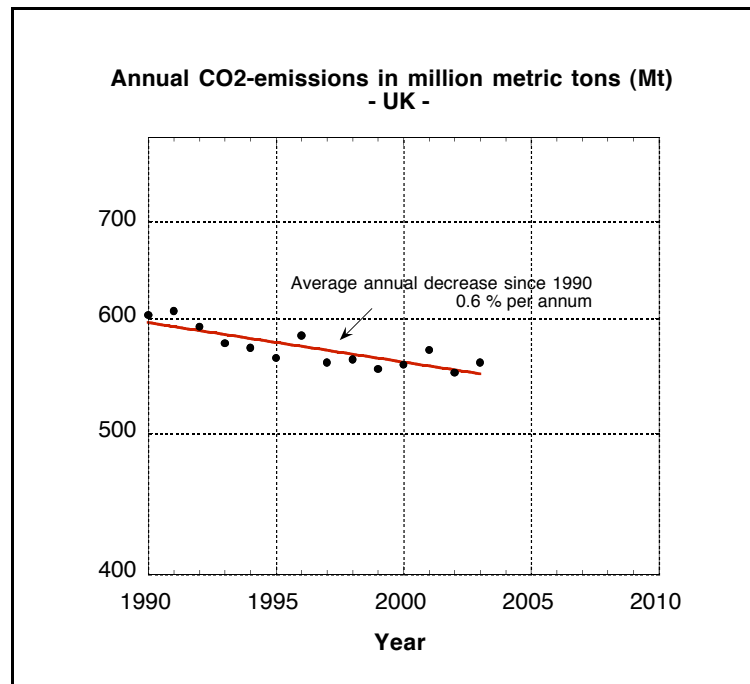

Fig. 11-3: Annual CO₂ emissions in the UK since 1990, displaying a steady annual decrease of 0.6% per year

Even the German government's own departments have apparently not managed to achieve the set target of reducing CO₂ output by 25% in their own buildings and fleets of official cars (Table 1-2) [9]. The conclusion we should draw from this fact is that, even in areas directly under the administrative control of the government, more time is needed to implement the set reduction targets than was thought necessary at the outset.

In view of the evident inertia that is slowing down progress in pollution control, a target of "minus 40% by 2020" would appear too ambitious from today's standpoint.

4. Instruments to further reduce emissions

Significant progress in efforts to stem greenhouse-gas pollution can be expected from the government scheme, launched in 2004, to issue a limited quantity of tradable CO₂ emission permits to industry. Each company concerned has to be in possession of sufficient permits (certificates) at the end of the corresponding period to match the level of emissions it has actually caused. The intended effect of EU-wide trading in emissions certificates, which was started on 1 January 2005, is to avoid emissions in those places where such avoidance can be achieved at the least cost. Although the level of emissions for which permits were issued without charge to the industrial sector (representing 58% of overall emissions in Germany) for the first period (2005-2007) lay only slightly below the sector's actual emissions in the years preceding 2002, and were thus politically acceptable, this system nevertheless places an extremely powerful instrument in the hands of the German government, the federal parliament, and the European Commission. Industrial firms producing more emissions than their allocated or purchased permits can be punished with fines or other disciplinary measures. In the long term, the effectiveness of this instrument will be heavily dependent on political conditions in Germany and Europe, and most especially on the CO₂ reduction targets agreed on in the EU. Its effectiveness will be all the greater if it becomes possible to integrate the consumer sector, where there is considerable unexploited scope for CO₂ avoidance (Chapter 2). Many observers were surprised to see the price of carbon permits rise from 20 to 22.65 €/t CO₂ between January and August 2005 [9a].

The compulsory measures introduced by the government to enforce compliance with the agreed emission limits are paralleled on the economic and technical side by the various options for supplying energy with the least possible emissions. **In order to achieve a better performance in terms of reducing emissions, German energy policy must spread its options as broadly as possible.** The necessary reorientation phase as the energy sector moves over to low-emission processes will last for several decades, making it important to have a choice of options because we cannot know in advance what the ultimate economic and technical outcome of any specific option will be. We therefore need alternatives, which can then be optimised on a competitive basis.

The first of these options is CO₂ sequestration at fossil-fired power plants. Sufficient experience in the separation of CO₂ and its long-term storage has already been gathered in projects around the world to allow power plants to be constructed that combine both elements. Given that industrial-scale projects are already beginning to be undertaken (see Chapter 9) and that the German government is helping to fund and co-ordinate the relevant research and development work (COORETEC programme), we can assume that this option is already an integral part of Germany's energy policy. As the price of CO₂ emission permits continues to rise, such power plants will soon reach profitable operating conditions.

In the interests of spreading the options for German energy policy as broadly as possible, it is appropriate to consider two further options that are not yet commonly recognised as instruments of German energy policy: extending the operating life of nuclear power plants and the construction of solar thermal power plants in southern latitudes.

5. Plea for the continued use of nuclear power

There is a basic conflict between the planning figures for CO₂ reduction, which now appear to have been overly optimistic, and the fixed timetable for phasing out nuclear power. Whilst originally we had hoped to have sufficient leeway to compensate for the loss of CO₂-free electricity derived from nuclear power, today we are forced to realise that such an equation will not balance out. Instead, what we must do is to prolong the phase-out plans over a realistic period of time commensurate with the reduction of CO₂ emissions. An insistence on adhering to the established timetable for phasing out nuclear power when we know that there is no possibility of meeting the set CO₂ reduction targets by the envisaged dates cannot be reconciled with the idea of genuinely reducing atmospheric pollution. The nuclear power plants ought to remain on stream until such time as a substitute has been found for their CO₂-free production capacity of 168 TWh/a, using renewable energy sources (or possibly fossil-fired power plants with CO₂ sequestration).

As mentioned in the chapter on nuclear power, this study does not attempt to venture an opinion either way, for or against nuclear power. Regardless of whether at some later date nuclear power should come back into favour or be abandoned altogether, all we wish to do is to stress the point that there is an illogical discrepancy between efforts to reduce CO₂ emissions and the apparent willingness to give up an energy source that produces 168 terawatt-hours of CO₂-free electricity each year. As the analysis proves, efforts to reduce CO₂ emissions so far have not been sufficiently productive to justify shutting down all nuclear power plants by 2020.

Other arguments concerning service life extension

German nuclear power plants have one of the best safety records in the world. Their operation is strictly monitored to the highest professional standards, they have been operating for twenty, sometimes thirty, years at a high level of reliability, and they are capable of running for decades more without any drop in safety standards, within the permissible limits imposed by the ageing of their components. The as-yet unresolved problem of choosing a final repository for the waste is not significantly augmented by allowing the plants to continue operating. The question of resources is without relevance.

The financial argument is also a powerful one, given that it costs very little to generate electricity in a nuclear plant. The quoted figure lies at around 2 cents per kilowatt-hour [10]. This is lower than the generating cost of practically all other forms of electricity, and especially so in the case of CO₂-free production from renewable energy sources, where the additional costs currently lie in the region of several billion euros per year.

In purely rational terms, everything speaks in favour of extending the service life of these plants, but non-rational and political arguments also have to be taken into account.

Political arguments concerning adherence to the withdrawal timetable

The argument has been put forward that the ability to produce electricity at low cost and

in baseload quality is a disadvantage [11] – because it slows down the development of alternative forms of electricity generation and energy-saving methods. This argument becomes somewhat more understandable if we bear in mind that we can only make reasonable progress under an effective policy to reduce CO₂ emissions by improving the efficiency of power generation and consumption patterns and by making use of CO₂-free energy sources. And the incentive to improve efficiency is undeniably greater if energy costs are high. But it is hardly logical to deliberately weaken the existing efficiency on the generating side in order to promote greater efficiency on the consumption side. It would be far better if government officials were to use all the power at their disposal to find a solution that reconciles price incentives to optimise consumption with cost-effective production methods. The carbon credit trading system is a suitable instrument for this purpose.

The fact should not be overlooked that the anti-nuclear movement has been passionately pursuing its cause since the 1970s, often employing less-than-rational arguments. Ever since the time of the Chernobyl disaster, and even before then, the safety standards applied in German nuclear power plants have been classed as entirely satisfactory. From the point of view of safety, there is nothing to oppose their operation – otherwise they would never have obtained the permission to run. Allowing the nuclear power plants to continue operating within the limits imposed by the ageing of their components in no way alters their safety.

Nevertheless, many politicians and citizens whose opinions were formed during the critical period in question have made it a point of honour to stand up in favour of “pulling out as soon as possible”. From the point of view of physical science, there is no valid reason for abiding by the agreed timetable for withdrawal from nuclear power. It is ultimately a question of *political power* that will determine the necessity of following this proposal according to the agreed timetable. It might be worthwhile considering to abolish the relevant federal law.

In view of the fact that Germany's contribution to global greenhouse-gas emissions only makes up 3-4% of the total, there is little that Germany can do in the physical sense to significantly improve the global climate situation. The intent and purpose of German climate change policy lies rather in making contributions that will encourage the other players in this global undertaking to invest the requisite joint efforts to tackle man-made global warming, the major problem of this century. The ultimate justification for this policy can thus be sought in *Germany's diplomatic, commercial, scientific and technological status*. It is a question of affirming Germany's role in Europe and as an active participant in shaping international climate change policies – the choice of being a leader or a follower.

The German government has chosen to adopt a leading role, in tune with the country's scientific, technological and industrial skills. Germany can only convincingly assume this role if the arguments that it puts forward and the performance it can be seen to deliver are not only rational, but are perceived in the international arena as being worthy of imitation. The unconditional implementation of the defined timetable for withdrawal from nuclear power tends to be regarded in international circles as a uniquely German problem. It by no means improves our prospects in diplomatic negotiations and export trade.

6. Plea for solar thermal power plants in southern latitudes

Seen from a physical and technical point of view, there can be little doubt that solar thermal power plants in southern latitudes represent one of the best options for supplying the requisite large quantities of CO₂-free electricity. The necessary research and development activities have been under way for around 25 years, and the technology was already ripe for commercialisation by the year 2000, which would have been an ideal opportunity for bringing it onto the market. Work on practical research, like academic papers, can be continued ad infinitum; but the route from laboratory prototype to industrial manufacturing, and from there to the construction of a fully fledged plant, is governed by its own particular time scale. It is a matter of urgency to take the necessary steps if we want to reap the benefits of this eminently suitable technology.

There are *three reasons* why Germany ought to take an interest in developing *and* commercialising solar thermal power plants:

- (a) Imports of electricity produced in solar thermal power plants could help to reduce and ultimately replace our dependency on fossil fuels, including natural gas.
- (b) By participating in the development of solar thermal pilot plants, German industrial firms could find themselves in a highly favourable position when contracts are later awarded for large numbers of higher-capacity plants.
- (c) Germany would be able to claim a higher allocation of carbon credits by participating in the construction of solar thermal power plants to provide electricity in the developing countries of the equatorial sun belt, under the terms of the Kyoto Protocol's Clean Development Mechanism (CDM).

German research centres are heavily involved in *research* into solar thermal power plants, foremost among them the German Aerospace Center DLR, which is one of the international leaders. This is *just one* of the main conditions for being a leading country in the field of solar thermal energy. An equally important aspect at the present juncture is the existence of *commercial incentives* for promoting the market penetration of solar thermal energy, as has been the case over recent years in connection with wind power, enabling German (and Danish) manufacturers of wind turbines to capture a large share of the market.

Spain has promulgated a new law on the acceptance of energy inputs to the national grid and launched three pilot projects for solar thermal energy (based on different technologies and limited to an output of 50 megawatts), thus taking a first step towards creating a market for solar thermal energy. A second step, envisaging the construction of larger plants, intends to include sites in the countries of North Africa that might be considered as potential electricity suppliers to Central Europe.

Germany has approved the Joint Implementation and Clean Development Mechanism instruments for which provision has been made in the Kyoto Protocol. But the country still lacks a coherent strategy for significantly reducing greenhouse emissions by investing in suitable projects overseas, particularly in the developing and newly industrialised countries.

Use of the Clean Development Mechanism [12]

The Clean Development Mechanism (CDM), defined in Article 12 of the Kyoto Protocol, was created to provide a financial incentive for undertaking joint projects with a developing or newly industrialised country. According to the provisions of the Kyoto Protocol, the CDM has two parallel objectives. The first is to give the investor nations an additional means of attaining their Kyoto emissions targets; the second is to help the host nations along the road to sustainable development. It allows nation states and industrial firms to acquire carbon credits (Certified Emission Reductions, CERs) by investing in cleanup projects in developing or newly industrialised countries. The EU, and latterly Germany too, have established a legal framework that allows CERs to be converted into emission permits under the EU carbon trading scheme from the beginning of 2006 onwards.

In order to place the export of German solar thermal power plant technology on a solid financial basis, adequate safeguards often need to be provided to cover shortfalls in production, especially in the case of export markets with an elevated (economic and political) risk. Government export credit assurances are available to cover the risk of foreign business transactions (Hermes insurance). If a project involves direct foreign investments in the country awarding the contract, investment guarantees can be employed to assure against political risks. The export of renewable energy technologies is seen as a priority funding area by the German government. In response to an initiative by the German government, the OECD member states voted in favour of prolonging the loan guarantee period for solar power plants and similar projects to 15 years as of 1 July 2005, for a trial period of two years.

Specific conditions applicable when carrying out a CDM project are commented upon elsewhere [13].

Necessary action

To assure Germany's long-term power supply with electricity produced using CO₂-free processes, the appropriate government bodies should encourage power plant operators to start by constructing pilot plants of relatively high capacity to serve the local population in the sunbelt countries. This should be done by forging contacts and where necessary signing agreements with the partner nations, and backed by loan guarantees granted under the terms of the Clean Development Mechanism. At a later stage these facilities could serve as the foundation for building up a power supply infrastructure to serve Germany as well; this stage would involve further major investments to increase solar-electric generating capacity and for the construction of new high-voltage power lines from North Africa to Central Europe.

It would be a serious omission if Germany, owing to lack of foresight, were to let many more years pass before embarking on a programme to create a market for solar electricity. For even if the work should be launched rapidly, it would require the mobilisation of all available resources for a supply of electricity from this programme to start arriving in Germany by 2020.

In recent years, the Deutsche Physikalische Gesellschaft has repeatedly and decisively spoken out in favour of this promising avenue to reducing CO₂ emissions. Here once again, it appeals to all the parties involved – industry, energy providers and the appropriate government bodies – to do everything in their power to urgently launch the outlined programme to create a market for CO₂-free solar thermal power plants.

Notes and references

- [1] The proportion of natural gas in the mix of fossil fuels used to generate electricity should not be confused with its share of installed capacity. The latter figure is much higher, because the gas-fired power stations only operate for part of the year. In 2003, for instance, the ratio of natural gas to total installed capacity was 0.25, as opposed to a ratio of 0.16 of the electricity output.
- [2] cited in: *Das IKARUS-Projekt, energietechnische Perspektiven für Deutschland*, ed. P. Markewitz and G. Stein (final report on the IKARUS project), a publication of the Research Centre Jülich, in the *Umwelt* series, Vol. 39, Jülich 2003. Table 5.4
- [3] Ibid., Table 5.5
- [3a] Prognos, EWI, *Die Entwicklung der Energiemärkte bis zum Jahr 2030*, a study commissioned by the Federal Ministry of Economics and Labour (BMWA), Cologne, Basle, April 2005
- [4] EEG-2004 Paragr. 1
- [4a] Federal Ministry of the Environment, *Umweltpolitik, Erneuerbare Energien in Zahlen*, Berlin, June 2005
- [4b] www.vdn-berlin.de/eeg_mittelfristprognose.asp
- [5] Nitsch et al. (DLR, ifeu, WI) on behalf of the BMU, *Ökologisch optimierter Ausbau der Nutzung erneuerbarer Energien in Deutschland*, Stuttgart, Heidelberg, Wuppertal, March 2004
- [6] Replaced annual nuclear power output (168 TWh) • CO₂ emitted by substitute power plants per kWh (699.5 g) = 117.5 Mt CO₂
- [6a] Conversion factor 699.5 g CO₂/kWh, Table 2
- [7] NETCEN on behalf of the Department of Environment, Food and Rural Affairs
- [8] *Labour Manifesto 1997*, and less distinctly in *Energy Paper 2003*
- [9] No official figures are available, but they would certainly have been published if the target had been achieved.
- [9a] The development of the market for European emissions permits between January and August 2005 is described in the London publication *Argus Power Europe*, Vol. V, 16 (25.8.2005), pp. 6-7.
- [10] e.g.: Helmut Alt, lecture at the Physikertagung München 2004, published in: *Perspektiven für die Energie der Zukunft*, 13 seminar lectures, ed. M. Keilhacker, Deutsche Physikalische Gesellschaft, Bad Honnef 2004
- [11] J. Trittin, *Welt um Welt, Gerechtigkeit und Globalisierung*, Aufbau Verlag Berlin 2002, p. 11
- [12] We are grateful to Dr. Christoph Bals of GermanWatch, Bonn, for his expert advice on the Clean Development Mechanism. The text that appears here is a considerably abridged version of his written paper, which contains numerous significant comments and practical information. The 4-page paper is posted on the DPG's Internet site at the address given in note [13].
- [13] <http://www.dpg-fachgremien.de/ake>

12 Concluding remarks

Man-made climate change cannot be stopped in the foreseeable future, rather it is a problem of a century and beyond. We only need to look back at the major technological advances of the previous century (electricity, the automobile, aviation, telecommunications, computers, modern chemistry, nuclear physics, power engineering, medical devices ...) to realise that the world has changed in many more ways than it would have been possible to predict. Similarly, we have no way of knowing in advance what possibilities will be revealed to us in the course of the 21st century. We are allowed to hope that new inventions will see the light of day, and that we will be able to optimise existing technologies by exploiting the strengths of the competitive market economy.

If one day we were able to develop a new rechargeable energy storage device which, for the price of a car battery and of the same weight, offered 30 times the storage capacity, our transport system could be completely revolutionised. We would be able to drive around in electric cars running on batteries that are recharged while the car is parked, perhaps using electricity produced by wind turbines or solar power plants. If one day we were able to grow algae in culture beds that produced hydrogen gas directly from water and sunlight, they might provide the technical basis for a viable hydrogen economy.

These examples illustrate the fact that attempts to tackle the problem of global warming are first of all a challenge to our intellectual skills. It would be no small service on the part of Germany to the rest of the world if its research laboratories and engineering workshops were to contribute important ideas leading to future technological progress. Taking steps to enable them to pursue the necessary research on the basis of well-founded premises, and actively creating a "research climate" that leads to productive results, are of essential importance to the objective of preserving our global climate.

Authors

(Members of the energy working group)

Prof. Dr. Walter Blum,
Max Planck Institut für Physik, Munich,
currently at CERN, Geneva
Chairman of the energy working group,
study co-ordinator
walter.blum@cern.ch

Dipl.-Ing. Wolfgang Breyer, Erlangen,
former head of corporate communications
at Framatome ANP GmbH
wolfgang.breyer@kerntext.de

Dr. rer. nat. Eike Gelfort, Cologne
VDI nuclear energy committee,
formerly with the research ministry BMBF,
Ref. 413
e.gelfort@gmx.de

Dr. rer. nat. Arnold Harmsen,
engineering consultant, Hamburg
a.harmsen@plenuming.de

Prof. Dr. Martin Keilhacker,
Max Planck Institut für Plasmaphysik,
Garching
former director of the JET laboratory,
Culham, UK
martin.keilhacker@softdesign.de

Dr. Gerhard Luther,
Head of the Office for
Future Energy Systems,
University of the Saarland, Saarbrücken
luther.gerhard@vdi.de

Prof. Dr. Andreas Otto, em.,
experimental physics,
University of Düsseldorf
otto@uni-duesseldorf.de

Dipl.-Ing. Günther Plass, Geneva
former Director of Accelerators, CERN
g.i.plass@freesurf.ch

Prof. Dr. Eckard Rebhan,
theoretical physics,
University of Düsseldorf,
publisher of the
Springer-Verlag energy handbook
rebhan@thphy.uni-duesseldorf.de

Publishing notes

Publisher and copyright (2005):
Deutsche Physikalische Gesellschaft e.V.
Hauptstraße 5
53604 Bad Honnef
Phone: ++49 (0)2224-9232-0
Fax: ++49 (0)2224-9232-50
dpg@dpg-physik.de

Berlin branch:
Magnus-Haus
Am Kupfergraben 7
10117 Berlin
Phone: ++49 (0)30-201748-0
Fax: ++49 (0)30-201748-50
magnus@dpg-physik.de

Press office:
Rathausplatz 2-4
53604 Bad Honnef
Phone: ++49 (0)2224-95195-18
Fax: ++49 (0)2224-95195-19
presse@dpg-physik.de

This study can be found on the Internet at:
<http://www.dpg-fachgremien.de/ake>

Responsible for content:
Deutsche Physikalische Gesellschaft e.V.
Every reasonable effort has been made to
ensure that all figures and statistics quoted
in this text are correct. Nevertheless, we
cannot assume any responsibility for
possible errors.