

Table of contents

1. How to Calculate Required Digester Volume	2
2. Preparation of Construction Materials and Appliances	3
3. Construction and Material Installation	4
3.1. Digester construction.....	4
3.1.1. Digging.....	4
a. Construction site selection.....	4
b. Digging.....	4
3.2.2. Making digester foundation.....	4
3.1.3. Bricklaying of the walls	5
3.1.4. Mortar and cement liquid plastering.....	5
3.1.5. Making digester concrete	6
a. How to assemble mold and install supporters of the mold to construct digester concrete.....	7
b. How to determine and make the technical hole during construction of top concrete.....	7
c. Preparing and casting iron rods	8
d. How to mix cement to construct top concrete 200B.....	8
e. Concrete thickness.....	8
f. Concrete vibration and maintenance.....	8
g. Making technical hole cover	9
3.1.6. Making concrete of worktop for cooking.....	9
3.2. Installation of appliances.....	10
3.2.1. Installation of inlets (siphon).....	10
3.2.2. Installation of outlet system	11
3.2.3. Installation of bottle safety valve	12
3.2.4. Installation of gas reservoir	12
a. How to install gas reservoir	13
b. Technique in tying gas reservoir	13
c. How to tie gas reservoir with plastic tube at its end	13
d. Selection of place for gas reservoir	13
e. Operation	13
3.2.5. Installation of biogas burners	14
3.3. Filling soil around the digester.....	14
4. Attention for Operation and Maintenance of Biodigester – Vacvina Model.....	15
4.1. Feeding raw materials into digester.....	15
4.1.1. First feeding of manure	15
4.1.2. Daily feeding of manure.....	15
4.2. Operation of biodigester.....	15
4.2.1. When reservoir is full of gas	15
4.2.2. When gas burners in operation.....	16
4.2.3. When whole system in use	16
4.2.4. Warning of chemical into digester	16
5. Appendix	17
5.1. Practical exercise in calculation of total volume of a digester, construction materials and investment cost.....	17
5.1.1. Ouch Veasna family (Takeo province).....	17
5.1.2. Thap Chaney (Kampong Speu province)	19
5.2. Detail designs of biodigester system	22

INTRODUCTION TO CONSTRUCTION OF HYBRID BIO-DIGESTER – VACVINA

The objective of this book is to provide trainees with the process at each step as well as technical concept in building Vacvina bio-digester with its significant modification as follows:

- ▶▶ Study possible digester construction site on basis of geographical and soil condition;
- ▶▶ Technical design in building and fixing underground tanks;
- ▶▶ How to prepare and install equipments for Vacvina plant; and
- ▶▶ Other factors to operate and maintain Vacvina tanks.

1. How to Calculate Required Digester Volume

The size of a biogas plant which can be used for storing manures collected from husbandry activities is calculated based on the number of pigs raised by each household; how many pigs do they have?; meaning the number of pigs is required to know so that we can make the right and appropriate decision on building it. In general, the calculation of the volume of a biodigester (fed with animal manure, urine...) has to depend closely on the fundamental hypotheses that relates from one another including daily feeding of manures by each household, retention time, concentration of manure and water solution before being fed into the digester through siphon inlets, etc.

The size of digesters can be calculated by the formula below:

$$V_d = V_{ck} + V_{ph} \quad (1)$$

- ☞ V_d : Total volume of a digester
- ☞ V_{ck} : Gas storage volume
- ☞ V_{ph} : Digester volume

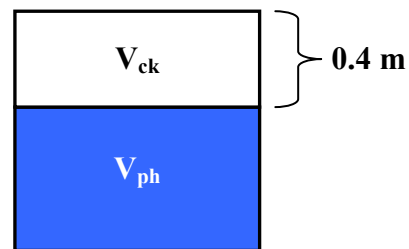

Given, $V_{ph} = T \times V_{dm} \quad (2)$

That is,

- ☞ T : Retention time of manure staying in the digester which is from 30 to 50 days (starting from the day it is fed into the digester until it is digested and flows out through the outlet).
- ☞ V_{dm} : Quantity of manure mixed with water fed into the tank on daily basis (litre per day).

At the pig farm, water pumped is used for directing manure in the pigsty to the digester, thus the formula to calculate quantity (V_{dm}) of water and manure (fresh) daily fed in the tank is defined below:

$$V_{dm} = W + nL \quad (3)$$

☞ W : Quantity of water (litre) used for mixing with manure of n pigs.

We know, on average, one pig produces L of manure (litre/day) at which the ratio between manure and water is 1 : 5 (1 manure-5 waters).

From the above ratio, we obtain:

- ⇒ Because one pig produces L of fresh manure, n pigs produces $L \times n$ of fresh manure = nL
- ⇒ Because one pig needs $W = 5L$ of water, n pigs need $W = 5L \times n = 5 nL$ of water

When $W = 5 nL$ is replaced in the formula (3), we obtain:

$$V_{dm} = 5 \text{ nL} + nL = 6 \text{ nL} \quad (4)$$

When $V_{dm} = 6 \text{ nL}$ is integrated into formula (2), we get:

$$V_{ph} = T \times 6 \text{ nL} = 6 \text{ nLT} \quad (5)$$

Given, $V_{ck} = h \times S$

- **S** : An area of a digester cover (m^2)
- **h** : Height of gas storage space from underneath cover of the tank to the level of slurry inside the digester (m), and in general **h** is defined to be 0.4 m.

$$\Rightarrow V_{ck} = 0.4 \times S \quad (6)$$

When $V_{ph} = 6 \text{ nLT}$ and $V_{ck} = 0.4 \times S$ are combined into the formula (1), we obtain:

$$V_d = (0.4 \times S) + (6nLT) \quad (7)$$

Formula (7) can be applied to calculate the size of a bio-digester at any pig farm.

In the formula (7), it is included:

- ☞ **n** : Number of pigs raised by every household
- ☞ **L** : Quantity of fresh manure collected daily per pig (litre/pig/day). In case of adult pigs, $L = 2 \text{ litres/pig/day} = 0.002 \text{ m}^3/\text{pig/day}$.
- ☞ **T** : Retention time the manure is staying in the digester (days).

2. Preparation of Construction Materials and Appliances

The materials and appliances for construction of a 7-m^3 biodigester – VACVINA mode – include:

No	Description	Unit	Quantity
1	Solid brick	piece	1,400
2	Cement	kg	600
3	Yellow sand (not mixed with silt)	m^3	1.5
4	Gravel or small stone (1 x 2 cm)	m^3	0.5
5	Iron bar (diameter of 8 mm and smooth)	kg	30
6	Metal pipe	piece	1
7	PVC pipe (diameter of 21 mm)	m	4
8	Valve & metal connector	set	15
9	Plastic gas-conducted pipe	m	15
10	Gas reservoir	bag	2
11	Siphon pipe	set	2
12	Biogas burner	set	2
13	Glue and paper tape		
14	Hoe, digging hoe, shovel, pickax, ax, rotten bucket, pounder for compacting soil, crowbar, hacksaw, saw, trowel, mortarboard for plastering, water hose, plastic bucket, mortar bucket, drum, zinc sheet, palm broom, brush for plastering mortar, water container, tent, motor rubber tube, wooden pole, torch, vibrator, jack, cow string, nail, measuring tap, metal-cutting scissors, pliers,		

	adjustable spanner and wooden mold.		
--	-------------------------------------	--	--

3. Construction and Material Installation

3.1. Digester construction

3.1.1. Digging

a. Construction site selection

The biodigester for every household should be constructed at the most favorable location which makes it easy for transportation of manure from animal farms to feed in the tank. The biodigester, therefore, should be placed nearby or beneath pigsty, while its shape should be designed according to the area condition or situation.

b. Digging

After the selection of the construction site and design, we start digging a digester pit, and its size must be a bit larger the required tank that makes us convenient for construction.

In determining the size of a digester, it depends on the actual condition of the land area for construction. However, in order to smoothly run the household investment in biodigester building, it would be ideal to be pay attention to the following characteristics: **the digester depth ranging from 1.5 to 5 metres, most favorably from 1.8 to 2 metres, width of less than 2 metres, and length depending on capacity desired.**

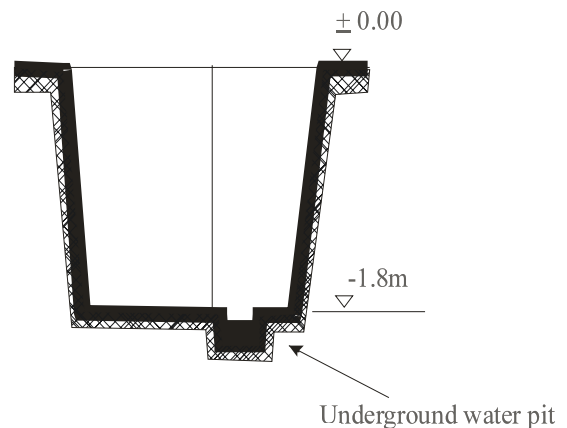

Fig 1: Digging digester hole and underground

Remark: If the dug pit is by chance in area with low level of underground water, it is necessary another small pit be prepared to temporarily store it, and then pump or remove it so as to make the foundation work convenient.

3.2.2. Making digester foundation

After the digging is completed with the accurate determination of dimensions of a tank, we continue to construct its supportive foundation as following steps:

- Lay pieces of broken bricks or small stones (diameter of 4 x 6 cm) for 10 cm layers, and then compact and spread them evenly;
- Apply gravel or small stone (diameter of 1 x 2 cm) for another layer of 3 cm thickness; and
- Make 5 cm thick concrete at ratio: 1 cement, 2 sands and 3 small stones (dia. of 1 x 2 cm).

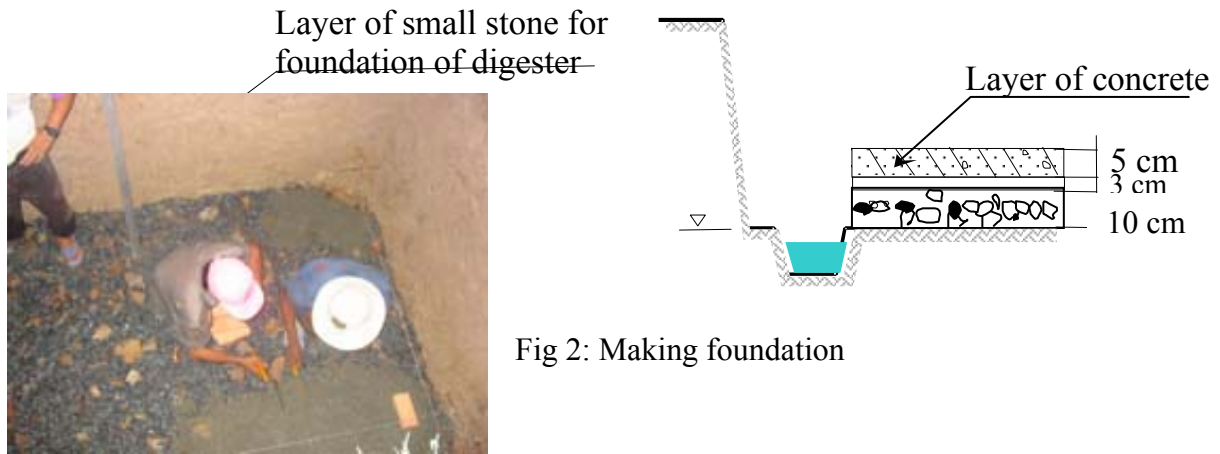

Fig 2: Making foundation

Remark:

- ➔ If the plant is built on soft and wet land (bad condition), iron bars should be added in the concrete to increase strength of the foundation. The iron bars should be 8 mm in diameter and cast in checked pattern with gaps of 20 cm.
- ➔ In case there is too much underground water while conducting the concrete work, it needs to be gradually pumped out of the pit, or a plastic sheet needs to be laid over the foundation area, in order to protect leakage or disturbance from the water.

3.1.3. Bricklaying of the walls

While the digester foundation work is finished, we commence to lay bricks to construct the walls. In construction of the tank walls which is similar to that of high buildings with their thickness of 10 cm (i.e. thickness of single brick), high quality solid bricks are used together with cement and sand at ration of 1 cement and 4 sands.

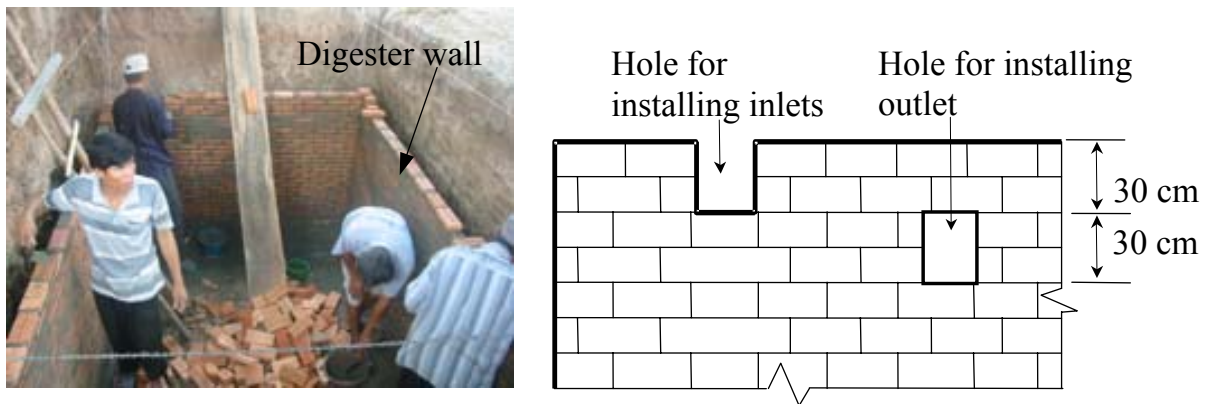

Fig 3: Position for installing inlets and outlet

Notice: While doing the bricklaying, holes are technically determined for installing some materials such as inlets and outlet (see figure 3).

- ☞ Inlets are fixed at place which is closed to the top edge of the digester wall, and the dimension of an inlet is 30 cm high and 15 cm wide. However, they can be positioned apart.
- ☞ The position of an outlet is at 30 cm away from the top edge of the digester wall, and it must be 30 cm high and 15 cm wide.

3.1.4. Mortar and cement liquid plastering

Mortar and cement plastering work has the most significant role in ensuring the construction quality standard by which the tank must be waterproof and airtight, thus internally plastered mortar must be firm.

The sand mixed with cement for plastering the walls must be purified so that it is well mixed with the cement at ratio: 1 cement-3 sands.



Fig 4: Plastering mortar inside the tank to protect leakage

It is overall suggested the thickness of plastered cement and sand should be even, and the plastering should be pressed firm and smooth. At the corner of the walls, inward corns are recommended. The plastering of mortar and cement liquid should be carried out the following steps:

- ☞ First, the interior wall faces should be cleaned with clean water;
- ☞ Solution of cement (at medium rate), then, needs to be smoothly applied on the wall faces at the thickness of 1 mm (considered as the 1st layer);
- ☞ After that, one more layer of mortar (cement and sand) at 1 cm thickness should be made and then left it a bit dry on surface before it is evenly smoothed (2nd layer);
- ☞ Wait for 1-2 hours after plastering of the first and second layers to let them a bit dry, and then the cement solution is additionally spread at thickness of 1 mm in which the application method is similar to that of the first layer (3rd layer); and
- ☞ One hour later, cement solution needs to be applied at thickness of 1 mm ((4th layer).

Remark: While plastering the mortar over the wall faces, 5 cm gap down from the peak of every wall is left blank to connect with the digester concrete cover later. After the top concrete is made, parts with shortage of mortar must be additionally sealed. The corners between the digester cover and the walls must be conically sealed with mortar inward to ensure airtight (figure 4).

3.1.5. Making digester concrete

After the walls are built and plastered with mortar and cement solution, a top reinforced concrete is made to construct the digester cover.

As the tank concrete has the role to serve not only as a cover to create airtight but also as a flat floor for animal raising, the concrete must be 8-10 cm thick (according to the type of animals raised). The surface of the concrete must be flat, and it must be made directly by the mold assembled at the construction site (Any reinforced concrete produced at the factory is not recommended for used in this purpose).

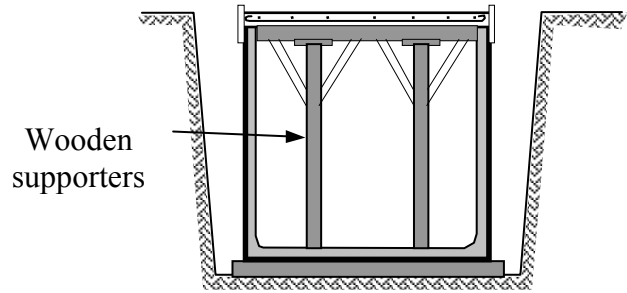

Fig 5: Assembling wooden mold and supporters for concrete

The preparation as well as construction technique are carried out in the same way as those of constructing tall buildings or houses we are staying in (fig 5). The construction process is as follows:

a. How to assemble mold and install supporters of the mold to construct digester concrete

The concrete mold and its supporters must be firmly and technically installed (the mold frame must have its strong supporters).

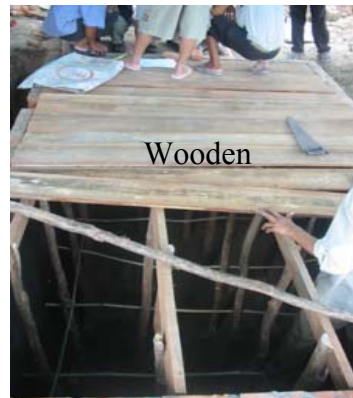

Fig 6: Assembling wooden mold and its supporters

b. How to determine and make the technical hole during construction of top concrete

A technical hole with the dimension of 70 x 70 cm on top must be readily made by a mold which had already been prepared with small wooden pieces and shaped in a semi-cylinder frame with the dimension of 70 x 70 cm on top, 50 x 50 cm at bottom, and 10 cm high (Fig 7). Iron bars used to construct the technical hole should be 8 mm in diameter and cast in square pattern of 10 cm². The roles of the technical hole are:

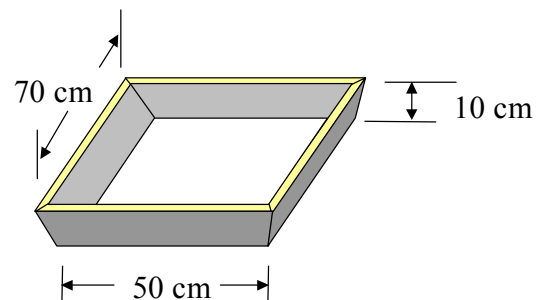

Fig 7: Mould of technical hole

- ◆ To serve as a hole to go in and out of the tank to remove the wooden floor and supporters of the mold from interior digester when the concrete is, according to the determined construction technical standard (7 days), dry and firm enough. Also, it acts as a hole to enter and get out of the tank to complete the last work such as installation of the inlets and outlet, etc.
- ◆ To be a hole for cleaning the digester when there is blockage or after it has been operated for years (normally estimated 7-10 years).
- ◆ The position of the technical hole should be analytically and appropriately determined to enable convenient operation (while going in or out of the digester, ensure that it doesn't affect the outlet and inlets ...), and it must not disturb or interrupt animal raising activities.

c. Preparing and casting iron rods

Iron rods used for building the top concrete must be a type of strong iron for construction, with dimension of 8 mm, and tied in square pattern of 15 x 20 cm and hooked at both ends (Fig 8). In case of large-size concrete, i.e. with width of over 2 m, it would be ideal if the work of both forming frame and casting iron rods was recommended by construction engineer.

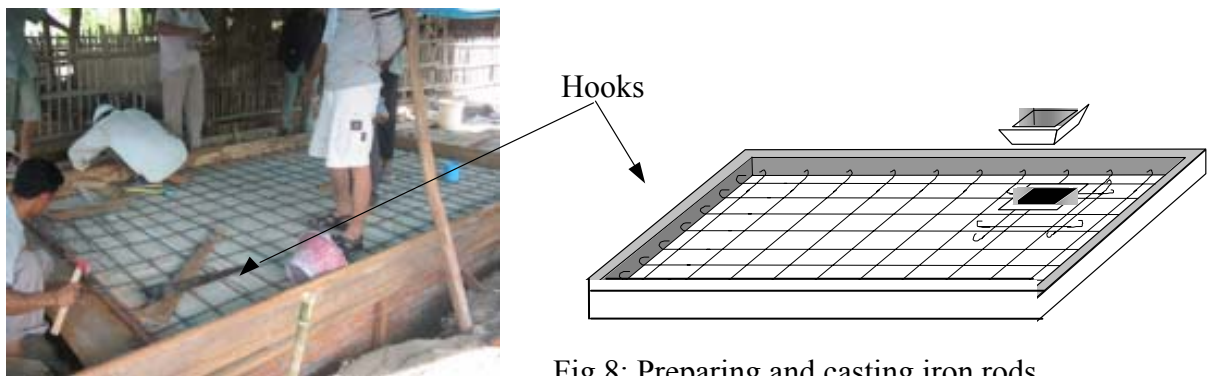

Fig 8: Preparing and casting iron rods

Notice: Around the technical-hole mold, iron bars should be added to increase strength (see figure 8).

d. How to mix cement to construct top concrete 200B

In mixing mortar, a ratio of 1 cement, 2 sands and 3 small stones must be followed.

e. Concrete thickness

The concrete must be 8 or 10 cm thick (when concrete work is done, it is recommended 2-3 sticks of 8 or 10 cm depending on the desired thickness be used as measuring tools to ensure correct thickness all parts of the concrete surface). Keep in mind, while casting concrete, install the metal gas-conducted pipe vertically with one of its ends buried and appeared inside the tank.

The gas-conducted pipe at the diameter of 21 mm should be located in a hidden place or in a place which may not make the space for animals narrow.

f. Concrete vibration and maintenance

In order to strengthen the concrete structure; concrete, while casting, should be technically vibrated with vibrator in respect of its following steps; meaning if the vibrator is run by the electricity, it is recommended the vibration activity stop when the concrete surface is apparently smooth and bubbles disappear, and the cement content starts to appear on the surface of the concrete.



Fig 9: Vibrating concrete

g. Making technical hole cover

After 2-3 hours, the digester top concrete becomes strong enough so that the technical hole mold can be removed, and then cement is used to smooth and shape the fresh technical hole at all 4 sides. After that, empty cement bags are used to lay at the bottom on the concrete mold floor and on all edges of the technical hole, and iron rods then need to be reinforced as a frame placed on the prepared cement bags so as to make the cover. Then, 5 cm thick concrete is made. In building the technical hole with its top area of 70 x 70 cm and its bottom surface of 50 x 50 cm, iron rods at 5 mm diameter are used and tied in checked pattern of 10 x 10 cm ($\text{Ø}6@100$), and their both ends should be hooked. Remember when casting iron rods, two handles are attached for use (close or open the technical hole) when necessary. The iron rod should be 10 mm in diameter.



Fig 10: Technical hole and its two covers



3.1.6. Making concrete of worktop for cooking

Worktop for cooking is a place on which biogas burners are located; and therefore, to make it more convenient for installation process of burners, worktop for cooking should be constructed at the same time as the top concrete of the digester.

The worktop for cooking should be 60 x 120 cm in surface and 6-8 cm thick. The iron rods for this purpose should be 6 mm in diameter and hooked at both ends. Also, they need to be tied in checked pattern of 20 x 20 cm.

Remark: When worktop for cooking is built, 3 holes at 27 mm diameter should be made, 1 of which must be 50 cm (centre based) away from the second hole, 10 cm away from the worktop edge at length and 35 cm from the worktop edge at width, while the third hole is positioned closed to the kitchen wall and used to install gas-conducted pipe connected from the tank to the burners (Fig 11).

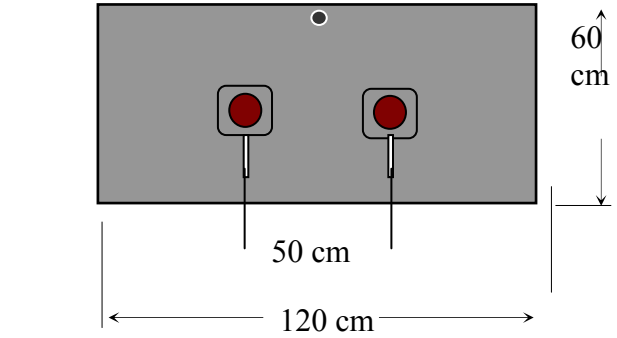

Fig 11: Plan and construction of worktop for cooking

3.2. Installation of appliances

After making the top concrete, technical hole and worktop for cooking; it moves to a stage of maintenance of concrete by following a proper method, in particular in dry season. 7 days after casting the concrete, its structure turns firm, and the supporters and wooden floor of the mold can be taken out so that other work begins accordingly. Be careful! Concrete soon after the removal of the mold is not fully strong, so it is recommended not to place any too heavy material on it.

3.2.1. Installation of inlets (siphon)

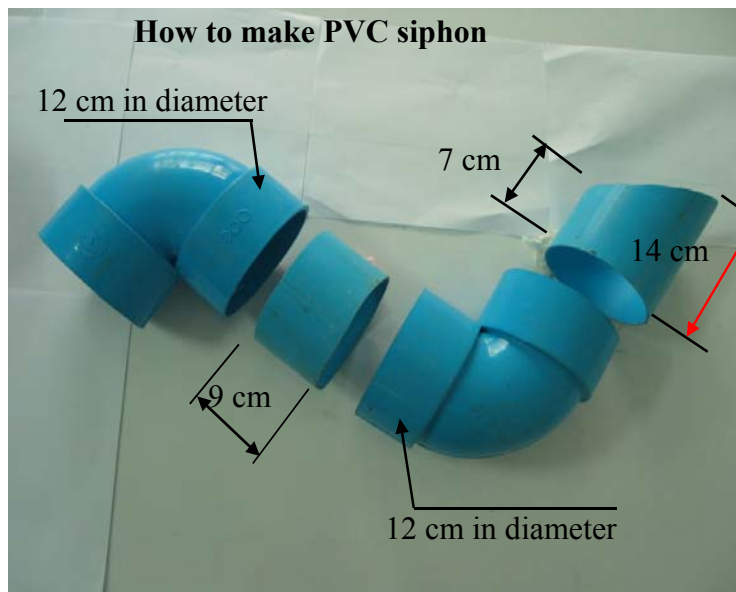

Fig 12: PVC siphon

Inlet system is a pipe to allow manure into the digester, and the pipe is connected to the drainage network attached with pigsties to collect droppings from compound around the animal raising site and direct them into the tank (Fig 12). Several years after operation of the biodigester, scum may develop on top of the slurry inside the tank. But with new technology that inlet system has been modified, manures fed into the digester break the scum, and thus no scum can be formed.

For every biodigester, two inlets may be installed and latrine can

also be attached directly on top of the tank.

Notice: Inlet can be called **siphon** which is composed of four PVC pipes at 10 cm diameter (see Fig 12).

↳ Siphon installation

As siphon has a role to direct waste into the bio-digester and to be a valve to protect biogas from leakage from the tank, siphon should be placed in the “**right position**”.

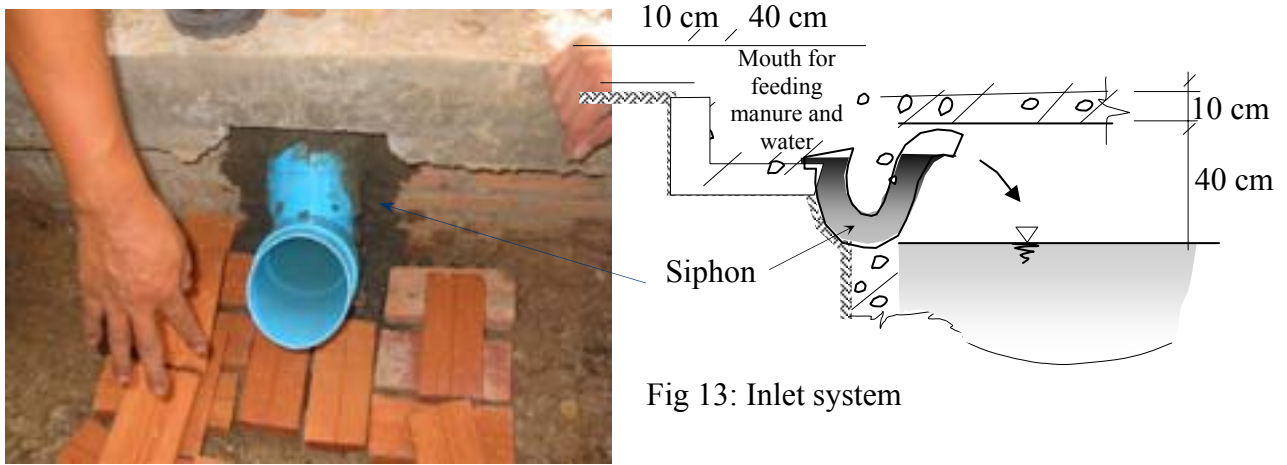

Fig 13: Inlet system

Place the siphon in the right position determined, and then fill it with water until it is full at its mouth outside the tank; soon after, the filled water spills out of siphon's mouth inside the digester, meaning the siphon position is considered technically right (see Fig 13). After that, seal it with cement until it is fixed.

Later, canals need to be built to gather animal dung and they have role to concentrate manure of reared animals both from the front and behind sections of the animal shed. The animal dropping is directed into the digester through this siphon system.

Warning: Installation of siphon prior to making top concrete is not recommended.

3.2.2. Installation of outlet system

After fixing the inlet system, we continue to install outlet system, which includes one pipe and one slurry pit used to store effluent from the digester.

- ★ Outlet pipe has a role to discharge slurry (effluent) from the main tank and then flow it to the slurry pit in order to balance slurry volume inside the digester, i.e. not higher nor lower the standard level according to time change. Outlet is made of PVC pipe 10-15 cm diameter and 70-80 cm length (Fig 14).

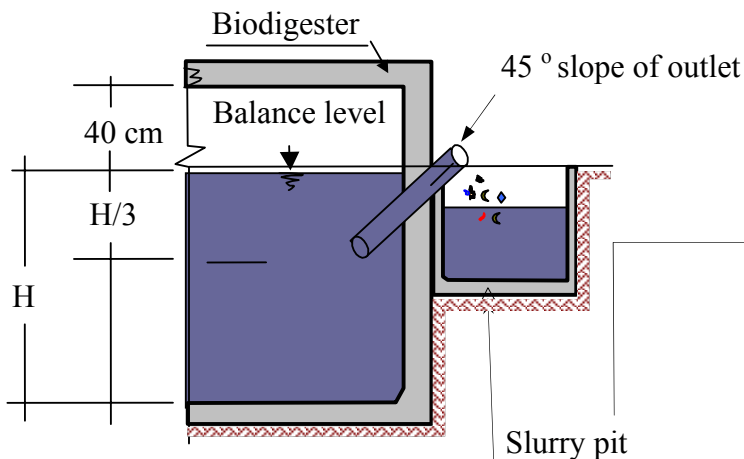

Fig 14: Outlet system

- ★ Outlet must be positioned lower than the siphon by locating it 40 cm below the underneath digester cover, and one end of the outlet pipe that needs to be buried into slurry inside the digester must be at the position of 1/3 of the total depth of the slurry, for instance, if the slurry depth is 1.65 m, one end of the pipe must be $165/3 = 55$ cm deep.
- ★ The size of the slurry pit varies by household, and it is located at the outlet. To ensure normal operation of the bio-digester, the level of slurry in the pit must always be lower than the level of the outlet's mouth.

After installation of inlets and outlet is completed, gas-conducted system and gas reservoir will be equipped. The gas-conducted system must be connected to the metal pipe already attached

to the top concrete during concrete making, and it has a role to direct gas to the reservoir and then to the burners.

Remarks: Before connecting the gas-conducted system to the metal pipe sit vertically at the top concrete; make sure that there is no any blockage inside the metal pipe. It is recommended the metal pipe's hole be checked with a steel stick at diameter of 8 mm.

3.2.3. Installation of bottle safety valve

Bottle safety valve has a role to insure pressure balance of biogas in entire system and, in general, a plastic tube (diameter of 21 mm) attached from the system is buried 10 cm deep into the water filled in the bottle (safety valve) in order to protect over-pressure of the system, i.e. the gas pressure excessive the capacity supported by the system automatically pushes out through this safety valve.

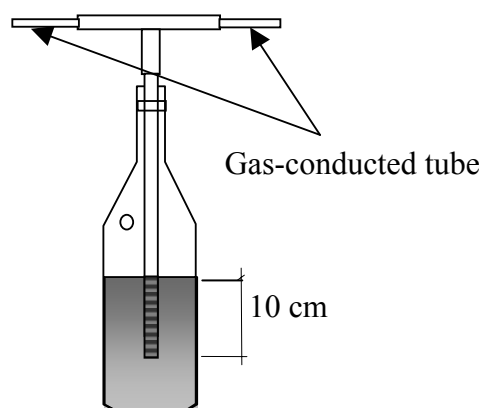

Fig 15: Safety valve

The safety valve is made of transparent plastic bottle with content of 2 litres, equipped with T-shaped tube (diameter of 21 mm at all ends) placed on top of the bottle. It is necessary a hole at the diameter of 12-20 mm be made and located under the bottleneck (see Fig 15).

How to operate safety valve: Firstly, a mark needs to be remarked at 10 cm from the bottom of the middle tube, and then fill water in the bottle up to the level of marked level (10 cm). If gas pressure in the entire system exceeds the pressure equivalent to 10 cm deep of water, the excessive gas will automatically push out through the hole underneath the bottleneck.

Position of safety valve: It should be located in a large (sunshine) space for convenience of later maintenance.

Remark: Often, water in the bottle safety valve must be controlled to see if it as high as the level marked (10 cm from bottom). If not, add water immediately until it reaches the fixed level. However, empty bottle must be avoided, or there will be **no gas** for cooking.

3.2.4. Installation of gas reservoir

Gas reservoir has is designed to receive and keep gas emitted from the tank for cooking. The gas balloon is recommended to be located beneath the roof of pigsty or animal shed or at a place without being interrupted by mechanical activities.

To meet demand of a household in cooking from 4 to 5 hours per day, there needs to be from 2 to 3 gas reservoirs in the system. Each reservoir is made of polyethylene (tough) and tubular with thickness of 20-24 μc (Micro Centimeter), length of 3.2 m and diameter of 90 cm while it

is filled with gas to maximum extent. A reservoir can content 1.8 m³ of gas, and normally one end of the balloon has to be firmly tied and the other end is inserted with a PVC tube at the diameter of 21 cm and tied it together with the reservoir with rubber.

a. How to install gas reservoir

Plastic reservoir is composed of two layers of plastic balloon, and in between the two layers, airtight must be ensured.

b. Technique in tying gas reservoir

To obtain well shape of gas reservoir while being loaded with gas, its both ends should be folded like fan by starting to fold it from its sides to middle (this would be clearly guided at the construction site), and then rubbers (bicycle or motor rubber tube) are used for tightening its both ends firmly running from inside.

c. How to tie gas reservoir with plastic tube at its end

Prior to folding gas reservoir at its both ends, the tube projected from the prepared T-shaped tube at diameter of 21 cm and length of 30 cm should be inserted in the middle of the balloon mouths where they are started to fold in a shape like waved fan. While tying, keep in mind to project 3-5 cm of the tube from the reservoir mouth.



Fig 16: Assembling two plastic layers for gas reservoir

d. Selection of place for gas reservoir

It is suggested gas reservoir be hanged in a proper way, not interrupting other daily activities, and creating convenience for operation. Normally, gas reservoir is placed under the top roof of kitchen or cattle shed, and it would be even better if it were located close to the kitchen (see Fig 19).



Fig 17: Folding gas reservoir

e. Operation

Every time of cooking with biogas, gas-suck fan can be used for sucking gas from the reservoir or rubber (bicycle or motorbike tube...) is employed for tying across the reservoir to push and obtain enough gas for cooking. After cooking is completed, turn off the fan or rubber from the reservoir so that the reservoir can receive new gas from the digester.



Fig 18: Double gas reservoir

3.2.5. Installation of biogas burners

Vacvina biogas burners are simple and easy for operation (see Fig 20). The burner is made of steel and rust proof, and it is composed of a fire-distributing device made of copper in the form of industrial burner with plenty of positive characteristics and it is not costly.

Installation of burners is the last work after fixing inlets, outlet and gas-conducted pipe system. In general, in order to enable convenient operation, worktop for cooking on which burners sit should be appropriately high and its platform was already concreted as mentioned in 3.1.6 section.

Biogas burners are connected to gas pipe equipped with a valve that can protect leakage while operation. In modern technology in installing burners, valves should be placed beneath worktop for cooking as shown in figure 20.



Fig 19: Installing gas burner

Notice: To ensure safety and convenience for operation, it is recommended to locate the valves at a suitable height by the worktop for cooking, and they must work well when operated.

3.3. Filling soil around the digester

After finishing installation of all appliances, we continue to fill soil surrounding the tank, which needs to be well done, and therefore sand is helpful in making soil firm and then spray water to increase solidarity of the filled soil and compact each of its layers carefully while complementing.

4. Attention for Operation and Maintenance of Biodigester – Vacvina Model

Before operation is started, clean interior digester and after that recheck the installed system to ensure airtight or leakage proof.

4.1. Feeding raw materials into digester

Vacvina biodigester was designed to help address environmental pollution resulted from livestock manures and is a source of substantial fuel for daily life, which may be extracted from dung of some kinds of animals such as cattle, poultry and human excreta.



Fig 20: Feeding manure

4.1.1. First feeding of manure

In order to obtain biogas faster, 800-1,000 kg of manure should be prepared in advance as raw material for the first feeding, and water is filled together with manure until it is seen flowing out through outlet.

4.1.2. Daily feeding of manure

To ensure durable and sustainable operation of biodigester, it is necessary to daily feed the digester with raw materials collected from cattle shed or pigsty and toilet.

Together with the above-mentioned manure, water is added at ratio of 1 manure to 5 waters. If water is overfed, then some amount of non-digested manure is flown out through outlet, since its digestion is limited, resulting in less gas production and the environment problem cannot be all solved, meaning manure still carries bad odor and diseases.

In this case, water for bathing cattle during hot weather should not be directed into the digester but through canals prepared by the owner upon request in order to avoid excess water in the tank.

4.2. Operation of biodigester

4.2.1. When reservoir is full of gas

We can start to use biogas for cooking. At the beginning, if gas can't be ignited due to the reason that it is not of high quality as it contains a lot of carbonic dioxide resulting from digestion of manure with oxygen remaining before closing the tank, first gas should be released from the reservoir, and wait until the next gas comes in which the balloon is refilled.

Keep in mind to turn off gas valve soon after operation is ceased. To start fire, first ignite fire-distributing device of the burner with lighter, and then adjust gas flow and flame to the desired level by the valve.

To obtain evenly distributed flame while operation, fire-distributing device made of copper should be frequently cleaned.

4.2.2. When gas burners in operation

If biogas doesn't supply sufficiently for cooking, rubber should be employed to tie across the reservoir to increase pressure inside the reservoir. After cooking, attention should be paid to remove rubber from the reservoir so that it can receive new biogas from the plant.

4.2.3. When whole system in use

If gas reservoir is seen loose, check the pipelines and gas reservoir system itself, valves... immediately for fear that they are bent or clogged, or control water in the bottle safety valve or at siphon inlets that it could be empty. If so, repair must be done urgently.

4.2.4. Warning of chemical into digester

Chemicals that are not allowed into the digester are soap, paint, rainwater..., as they interrupt reaction of bacteria in anaerobic condition. Presence of those chemicals may cause less biogas production or even stop production as a whole.

5. Appendix 5.1. Practical exercise in calculation of total volume of a digester, construction materials and investment cost

5.1.1. Ouch Veasna family (Takeo province)

There are 30 piglets, 16 adult pigs and 4 pig mothers.

Retention time = 30 days given, length = 3 m, width = 2 m, depth?

Remark: 3 piglets = 1 adult pig quantity of manure per pig = 2 kg/day

Calculate total volume of the intended digester, number of bricks, cement, sand, small stone and iron, and investment cost?

Solution

1. Digester Volume

Formula: $V_d = V_{ck} + V_{ph}$

$V_{ph} = 6nLT$?

$n =$ (total no. of pigs) = 30 pigs, L (amount of manure/pig/day) = 2 liters = 0.002 m³

T (retention time) = 30 days

Hence, $V_{ph} = 6 \times 30 \times 0.002 \times 30 = 10.8 \text{ m}^3$

Total volume of digester $V_d = V_{ck} + 10.8$

But $V_{ck} = 0.4 \times 3.3 \times 2 = 2.64 \text{ m}^3$ (Length = 3 m and width = 2 m)

Thus, $V_d = 2.64 + 10.8 = 13.44 \text{ m}^3 \approx 13.2 \text{ m}^3$

And $V_d = 13.4 = 3.3 \times 2 \times \text{Depth}$

Therefore, Depth = $13.44 : 6.6 \approx 2 \text{ m}$

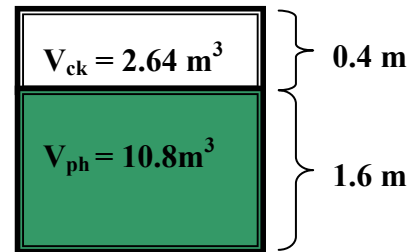

Conclusion: Interior length = 3.3 m or exterior length = 3.5 m

Interior width = 3 m or exterior width = 2.2 m

Depth = 2 m

Digester volume = $13.44 \text{ m}^3 \approx 13.2 \text{ m}^3$

2. Quantity of Bricks

Total area of wall faces?

Total area of wall faces = $2(3.5 \times 2.00) + 2(2.2 \times 2.00) = 22.80 \text{ m}^2$

Given $1 \text{ m}^2 = 80$ solid bricks

So, number of bricks for all wall faces = $80 \text{ bricks/m}^2 \times 22.80 \text{ m}^2 = 1,824 \text{ bricks}$

And number of bricks for wall foundation = $(3.5 \times 2 + 2.2 \times 2) \times 8 = 11.4 \times 8 = 91 \text{ bricks}$

Therefore, total of bricks = $1,824 + 91 = 1,915 \text{ bricks}$

3. Quantity of Cement & Sand for Laying Bricks and Plastering Mortar for Walls, and Small Stone for Top Concrete

a. Quantity of laying bricks & plastering mortar for walls = $22.80 \text{ m}^2 \times 25 \text{ kg/m}^2 = 570 \text{ kg}$

Because 1 m^2 of wall face requires 25 kg of cement

Given 1 sack of cement = 50 kg = 2 buckets (paint bucket), i.e. 1 bucket = 25 kg of cement

So, **570 kg of cement for laying bricks and plastering walls = $570 : 25 = 22.8 \text{ buckets (1)}$**

(Given ratio of cement and sand for laying bricks and plastering walls is 1 cement : 3 sands)

b. Amount of sand for laying bricks & plastering the walls = $22.8 \times 3 = 64.8$ buckets (2)

c. Quantity of cement for top concrete

Assume V_1 for volume of the top concrete

$$\text{So, } V_1 = 0.10 \times [3.30 + (2 \times 0.10) + (2 \times 0.05)] \times [2.00 + (2 \times 0.10) + (2 \times 0.05)] \\ = 0.10 \text{ m} \times 3.60 \text{ m} \times 2.30 \text{ m} = 0.828 \text{ m}^3$$

On the other hand, assume V_2 for exterior top concrete

$$V_2 = (0.05 \times 0.05 \times 3.6)^2 + (0.05 \times 0.05 \times 2.3)^2 = 0.0295 \text{ m}^3$$

$$\text{Then, } V \text{ (total)} = V_1 + V_2 = 0.828 \text{ m}^3 + 0.0295 \text{ m}^3 \approx \mathbf{0.858 \text{ m}^3}$$

Given 1 m^3 of concrete = 322 kg of cement

$$\text{Therefore, quantity of cement for concrete} = 0.858 \text{ m}^3 \times 322 \text{ kg/m}^3 \approx \mathbf{276 \text{ kg}}$$

d. Quantity of sand & small stone for top concrete

We know, 1 bucket of cement = 25 kg

$$\text{So, } 276 \text{ kg of cement for concrete} = 276 : 25 \approx \mathbf{11 \text{ buckets (3)}}$$

On the other hand, ratio of cement, sand and stone for concrete is 1 : 2 : 3

$$\text{Then, Quantity of sand} = 11 \text{ buckets} \times 2 = \mathbf{22 \text{ buckets (4)}}$$

$$\text{Quantity of small stone (1 x 2 cm)} = 11 \text{ buckets} \times 3 = \mathbf{33 \text{ buckets (5)}}$$

$$\text{Therefore, Total of cement} = (1) + (3) = 22.8 + 11 \approx \mathbf{34 \text{ buckets}}$$

$$\text{Total of sand} = (2) + (4) = 64.8 + 22 \approx \mathbf{87 \text{ buckets}}$$

$$\text{Quantity of small stone (1 x 2 cm)} = \mathbf{33 \text{ buckets}}$$

4. Total Amount of Construction Steel (D=8 mm) for Casting Concrete

Distance of steel cast in length of digester = $3.3 + 0.35 = 3.65$ m (interior length = 3.3 m)

Distance of steel cast in width of digester = $2 + 0.35$ m (interior width = 2 m)

Given, a gap from one steel to another cast in width = 0.15 m

And 0.35 is an invariable coefficient for calculation of one length of steel

$$\text{So, Number of steels cast in width of } 2.35 \text{ m} = (3.65 : 0.15) + 1 \approx 25 \text{ steels}$$

$$\text{Number of steels cast in length of } 3.65 \text{ m} = (2.35 : 0.20) + 1 \approx 13 \text{ steels}$$

We know, 1 m of 8-mm diameter steel = 0.386 kg

$$\text{Therefore, total quantity of steel for casting concrete} = [(25 \times 2.35) + (13 \times 3.65)] \times 0.386 \\ = (58.75 + 47.45) \times 0.386 \approx \mathbf{41 \text{ kg}}$$

Conclusion

- | |
|---|
| <ol style="list-style-type: none">1. Total volume of digester $V_d = 13.2 \text{ m}^3$2. Total number of bricks = 1,925 bricks3. Total quantity of cement = 34 buckets (paint bucket) = 17 sacks of cement4. Total quantity of sand = 87 buckets = $87 \times 0.02 = 1.74 \text{ m}^3$ (1 bucket = 0.02 m^3)5. Total quantity of stone (size 1 x 2 cm) = 33 buckets = $33 \text{ buckets} \times 0.02 = 0.66 \text{ m}^3$6. Total quantity of stone (size 8 x 10 cm) = $3.7 \times 2.4 \times 0.1 = 0.89 \text{ m}^3$ |
|---|

5. Investment Cost for a Bio-digester with Volume of 13.2 m^3

No.	Description	Unit	Qty	Unit Price (riel)	Total
1	Cement	kg	850	300	255,000
2	Steel (D = 8 mm)	kg	41	3,500	143,500
3	Sand	m ³	1.74	15,000	26,100
4	Solid brick	piece	1,925	135	259,900
5	Stone (size 1 x 2 cm)	m ³	0.66	48,000	31,700
6	Stone (size 8 x 10 cm)	m ³	0.89	10,000	8,900
7	Biogas burner	set	2	20,000	40,000
8	Gas-sucked fan	set	1	12,000	12,000
9	Plastic pipe	m	20	1,600	32,000
10	Plastic valve	unit	1	2,000	2,000
11	Metal valve	unit	2	5,000	10,000
12	Plastic reservoir	m	7	2,500	17,500
13	Glue	bottle	1	3,000	3,000
14	Paper glue	roll	2	1,500	3,000
15	Ring (plastic)	unit	10	800	8,000
16	Metal pipe (Ø = 21 mm, L = 10 cm)	pipe	4	1,500	6,000
17	Metal L-shaped pipe	unit	2	1,500	3,000
18	Metal connector with gear at both exterior ends	unit	2	1,000	2,000
19	Metal pipe (Ø = 21 mm, L = 1 m) and metal connector of Ø21 mm at one end and of Ø27 mm at the other	set	1	5,000	5,000
20	Steel (Ø = 6 mm)	kg	8	3,500	28,000
21	PVC pipe (Ø = 21 mm)	pipe	2	3,500	7,000
22	PVC L-shaped pipe (Ø = 21 mm)	unit	6	500	3,000
23	PVC T-shaped connector (Ø = 21 mm)	unit	4	500	2,000
24	PVC siphon	set	2	10,000	20,000
25	Adaptor	set	1	20,000	20,000
26	Nail (L = 5 cm)	kg	1	4,000	4,000
27	Nail (L = 8 cm)	kg	0.5	4,000	2,000
28	Nail (L = 10 cm)	kg	0.5	4,000	2,000
29	Labor cost for digging	m ³	14.4	5,000	72,000
30	Labor cost for constructors and technician	digester	1	300,000	300,000
Grand Total					1,328,600

Remark: US\$ 1 = 4,000 riel on May 2004

5.1.2. Thap Chaney (Kampong Speu province)

Number of adult pigs = 20, retention time = 40 days, assume length = 3.4 m, width = 1.8 m, depth?

Notice: 3 piglets = 1 adult pig (manure), amount of pig manure/pig/day = 2 kg.

Calculate total volume of the bio-digester, total quantity of bricks, cement, sand, small stone and construction steel and investment cost?

Solution

1. Total Volume

Formula: $V_d = V_{ck} + V_{ph}$

(V_d = Total volume, V_{ck} = Non-slurry volume in the digester, and V_{ph} = Slurry volume in the digester)

$V_{ph} = 6nLT$?

n = (total no. of pigs) = 20 pigs, L (amount of manure/pig/day) = 2 kg = 0.002 m³

T (retention time) = 40 days

Hence, $V_{ph} = 6 \times 20 \times 0.002 \times 40 = 9.6 \text{ m}^3$

⇒ total volume of digester $V_d = V_{ck} + 9.6$

But $V_{ck} = 0.4 \times (3.4 \times 1.8) = 2.45 \text{ m}^3$ (Length = 3 m and width = 1.8 m)

⇒ $V_d = 2.45 + 9.6 \approx 12 \text{ m}^3$

Therefore, $V_d = 12 \text{ m}^3$

And $V_d = 12 \text{ m}^3 = 3.4 \times 1.8 \times \text{Depth} = 6.12 \times \text{Depth}$

⇒ $\text{Depth} = 12 : 6.12 \approx 2 \text{ m}$

Therefore, **Interior length = 3.4 m or exterior length = 3.6 m**

Interior width = 1.8 m or exterior width = 2 m

Depth = 2 m

Digester volume = 12 m³

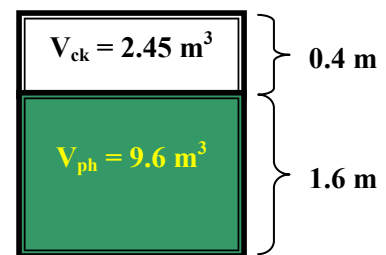

2. Construction Materials

* Total area of wall faces?

Total area of wall faces = $2(3.4 \times 2) + 2(1.8 \times 1.8) = 21.6 \text{ m}^2$

Given 1 m² of wall face requires 80 solid bricks and 25 kg of cement

⇒ Amount of cement for laying bricks and plastering all wall faces = $21.6 \times 25 = 540 \text{ kg}$

⇒ Number of solid bricks for digester walls = $21.6 \times 80 = 1,728 \text{ bricks}$

⇒ Quantity of sand for bricklaying for digester walls = $(540/25) \times 3 \times 0.02 = 1.3 \text{ m}^3$
(1 cement : 3 sands, and 1 bucket of sand = 20 liters = 0.02 m³)

* Calculation for the wall foundation

Total area of the wall foundation = $(0.05 \times 2) \times 4 + (0.05 \times 3.4) \times 4 = 1.08 \text{ m}^2$

We know 1 m² of wall face requires 25 kg of cement and 80 bricks

⇒ Amount of **cement** for wall foundation = $1.08 \times 25 = 27 \text{ kg}$

⇒ Number of **solid bricks** for wall foundation = $1.08 \times 80 = 87 \text{ bricks}$

⇒ Quantity of **sand** for wall foundation = $(27/25) \times 3 \times 0.02 = 0.065 \text{ m}^3$

* Calculation for the digester foundation

- Volume of stone (size 4 x 6 cm or 8 x 10 cm) layer for the digester foundation
= $(3.6 \times 2) \times 0.1 = 0.72 \text{ m}^3$

⇒ Quantity of **stone** (4 x 6 cm or 8 x 10 cm) for the digester foundation = **0.72 m³**

- Volume of stone (1 x 2 cm) layer for the digester foundation = $(3.6 \times 2) \times 0.03 = 0.216 \text{ m}^3$

⇒ Quantity of **stone** (1 x 2 cm) for the digester foundation = **0.216 m³**

- Volume of the foundation concrete of the digester = $(3.6 \times 2) \times 0.05 = 0.36 \text{ m}^3$

We know 1 m³ of concrete B200 requires 322 kg of cement

⇒ Quantity of **cement** for digester foundation = 0.36 x 322 = **116 kg**

⇒ Quantity of **sand** for digester foundation = (116/25) x 2 x 0.02 = **0.186 m³**

(Ratio of concrete B200 is 1 cement : 2 sands : 3 stones)

⇒ Quantity of **stone** (1 x 2 cm) for digester foundation = (116/25) x 3 x 0.02 = **0.28 m³**

*** Calculation for making top concrete of the digester**

- Volume of top concrete of the digester = V_{BT}

$$V_{BT} = \{0.1 [3.4 + (2 \times 0.1) + (2 \times 0.05)] \times [1.8 + (2 \times 0.1) + (2 \times 0.05)] + [(0.05 \times 0.05 \times 3.7) \times 2] + [(0.05 \times 0.05 \times 2.1) \times 2]\} \\ = (0.1 \times 3.7 \times 2.1) + 0.0185 + 0.0105 = 0.806 \text{ m}^3$$

⇒ Quantity of **cement** = 0.806 x 322 = **259.53 kg**

⇒ Quantity of **sand** = (259.53/25) x 2 x 0.02 = **0.415 m³**

(Concrete B200 ratio is 1 cement : 2 sands : 3 small stones)

⇒ Quantity of **stone** (size 1 x 2 cm) = (259.53/25) x 3 x 0.02 = **0.62 m³**

*** Quantity of iron bars for top concrete of the digester**

- Number of iron rods (Ø8 mm) in length = (1.8/0.2) + 1 = 10 bars

⇒ Amount of iron rods (Ø8 mm) in length = 10 x 3.75 x 0.386 = **14.48 kg**

- Number of iron bars (Ø8 mm) in width = (3.4/0.15) + 1 ≈ 24 rods

⇒ Quantity of iron bars (Ø8 mm) in width = 24 x 2.15 x 0.386 = **20 kg**

Conclusion

1. Total volume of digester V_d = 12 m³
2. Total number of solid bricks = 1,815 bricks
3. Total quantity of cement = 942.5 kg
4. Total quantity of sand = 1.97 m³ (1 bucket = 0.02 m³)
5. Total quantity of stone (size 1 x 2 cm) = 1.116 m³
6. Total quantity of stone (size 4 x 6 cm or 8 x 10 cm) = 0.72 m³
7. Total amount of steel (Ø8 mm) = 34.48 kg

3. Investment Cost for a Bio-digester at 12 m³ Volume

No.	Description	Unit	Qty	Unit Price (riel)	Total
1	Cement	kg	942.5	300	282,750
2	Steel (Ø = 8 mm)	kg	34.48	3,500	120,680
3	Sand	m ³	1.97	15,000	29,550
4	Solid brick	piece	1,815	135	245,025
5	Stone (size 1 x 2 cm)	m ³	1.116	48,000	53,568
6	Stone (size 8 x 10 cm)	m ³	0.72	10,000	7,200
7	Biogas burner	set	2	20,000	40,000
8	Gas-sucked fan	set	1	12,000	12,000
9	Plastic pipe	m	20	1,600	32,000
10	Plastic valve	unit	1	2,000	2,000
11	Metal valve	unit	2	5,000	10,000
12	Plastic reservoir	m	7	2,500	17,500
13	Glue	bottle	1	3,000	3,000

14	Paper glue	roll	2	1,500	3,000
15	Ring (plastic)	unit	10	800	8,000
16	Metal pipe ($\varnothing = 21$ mm, L = 10 cm)	pipe	4	1,500	6,000
17	Metal L-shaped pipe	unit	2	1,500	3,000
18	Metal connector with gear at both exterior ends	unit	2	1,000	2,000
19	Metal pipe ($\varnothing = 21$ mm, L = 1 m) and metal connector of $\varnothing 21$ mm at one end and of $\varnothing 27$ mm at the other	set	1	5,000	5,000
20	Steel ($\varnothing = 6$ mm)	kg	8	3,500	28,000
21	PVC pipe ($\varnothing = 21$ mm)	pipe	2	3,500	7,000
22	PVC L-shaped pipe ($\varnothing = 21$ mm)	unit	6	500	3,000
23	PVC T-shaped connector ($\varnothing = 21$ mm)	unit	4	500	2,000
24	PVC siphon	set	2	10,000	20,000
25	Adaptor	set	1	20,000	20,000
26	Nail (L = 5 cm)	kg	1	4,000	4,000
27	Nail (L = 8 cm)	kg	0.5	4,000	2,000
28	Nail (L = 10 cm)	kg	0.5	4,000	2,000
29	Labor cost for digging	m ³	24	5,000	120,000
30	Labor cost for constructors and technician	digester	1	300,000	300,000
Grand Total					1,342,273 ≈ USD336

Remark: US\$ 1 = 4,000 riel on May 2004

5.2. Detail designs of biodigester system

Underground Biodigester

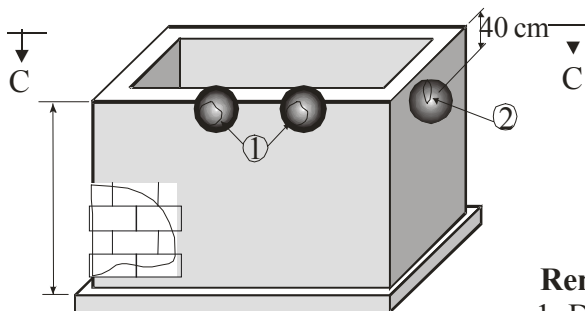

- ① Holes for siphon inlets
- ② Hole for outlet

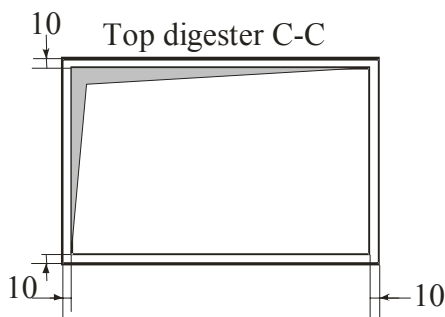

Remark

1. Digester foundation is comprised of 15 cm thick large stone and 3 cm thick concrete.
2. Digester wall is 10 cm thick, laying solid bricks with mortar at ratio of 1 cement to 4 sands.
3. Mason for plastering walls is 1 cm thick at ratio of 1 cement to 3 sands.
4. Apply cement mixed with water at thickness of 1 mm.
5. Arrange a hole to install siphons inlets and outlet based on the technical standard.

Plan - Flat top of digester

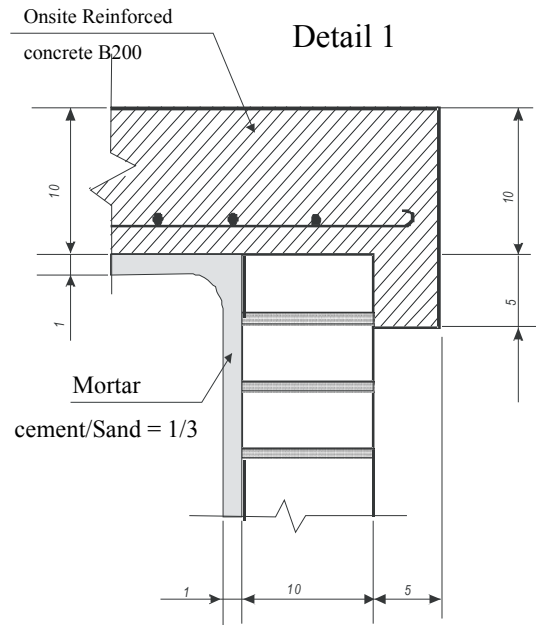
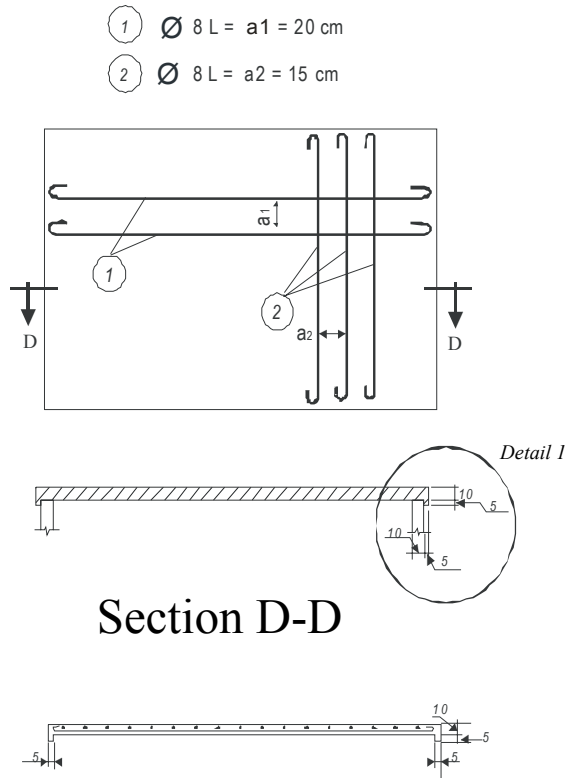

Detail - Technical Hole

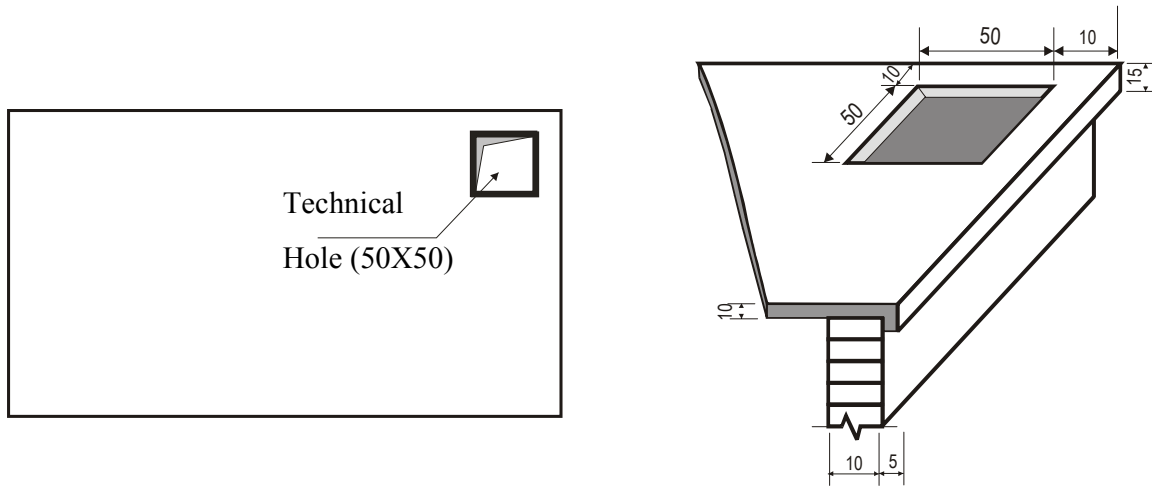

Note:

Detail - Technical Hole To be placed at a corner of the flat top of the Digester before casting it by reinforced concrete.

Technical Hole & its Cover

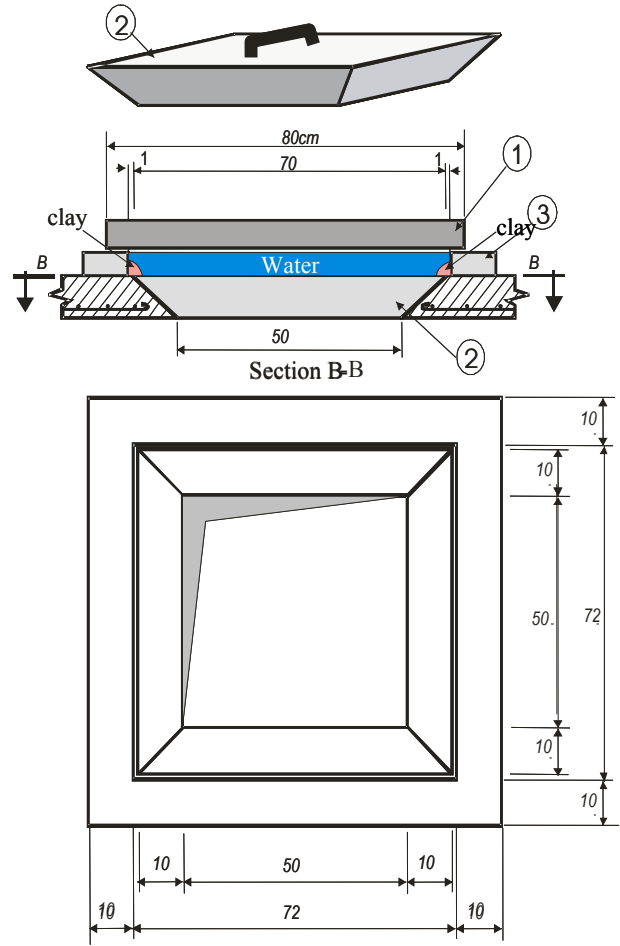
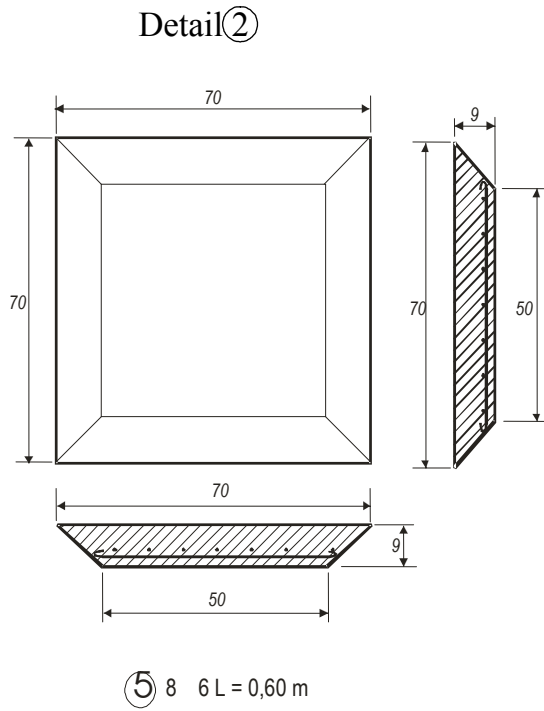

Detail Plan ③

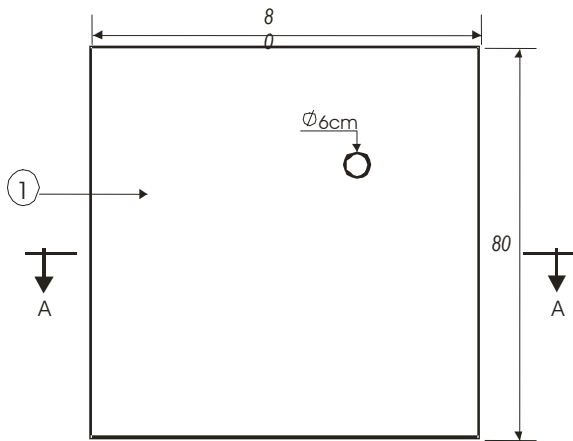

Detail ③

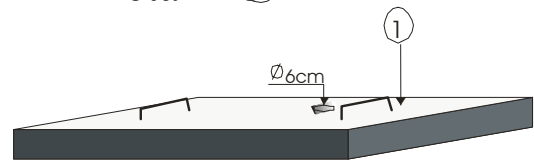

Mouth of Technical Hole

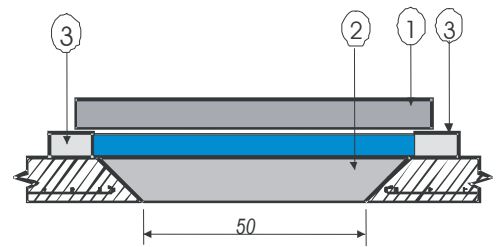

⑥ 10 6 L = 0.85 m

Detai

4

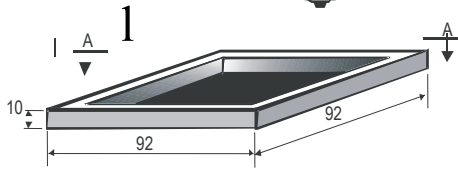

View A - A

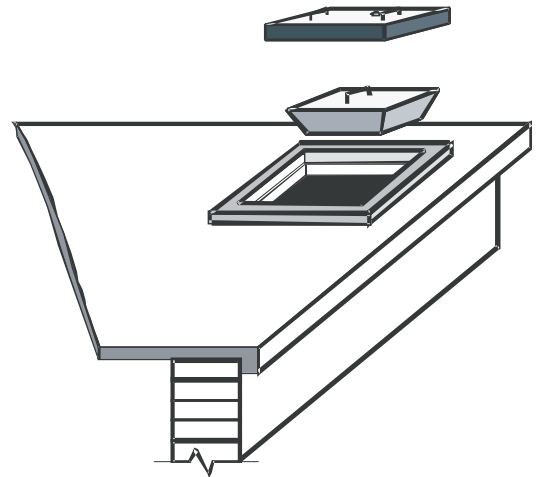
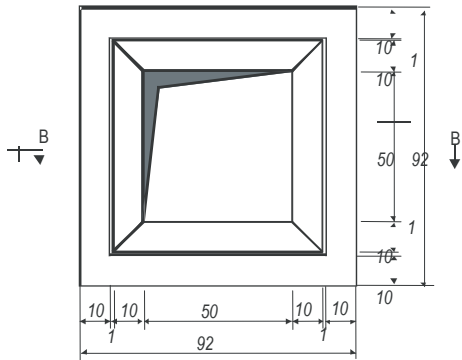

Section B - B

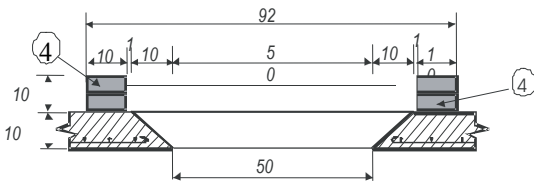

Design of Technical hole - covers

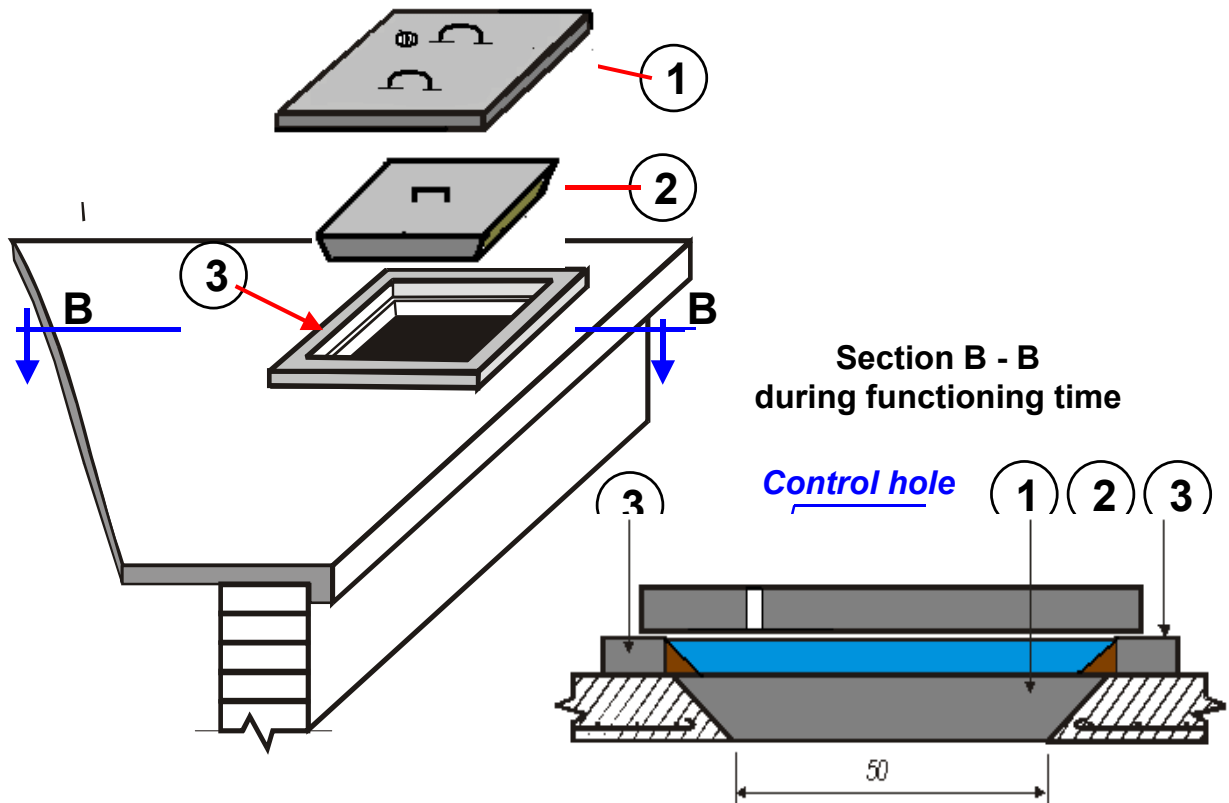

Plan-construction steel for Worktop for cooking

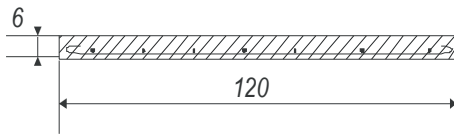
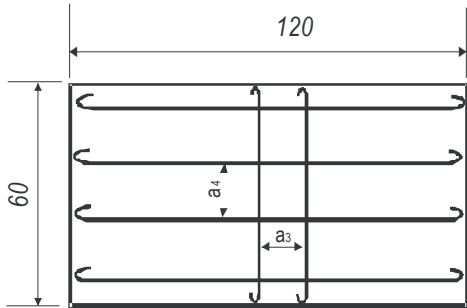

- ③ 4Ø6 L = 1,25 m ; a = 20 cm
- ④ 7Ø6 L = 0,65 m ; a = 20 cm

Worktop for cooking

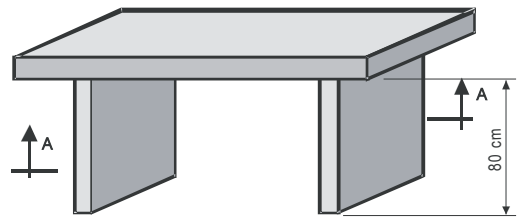

View A-A

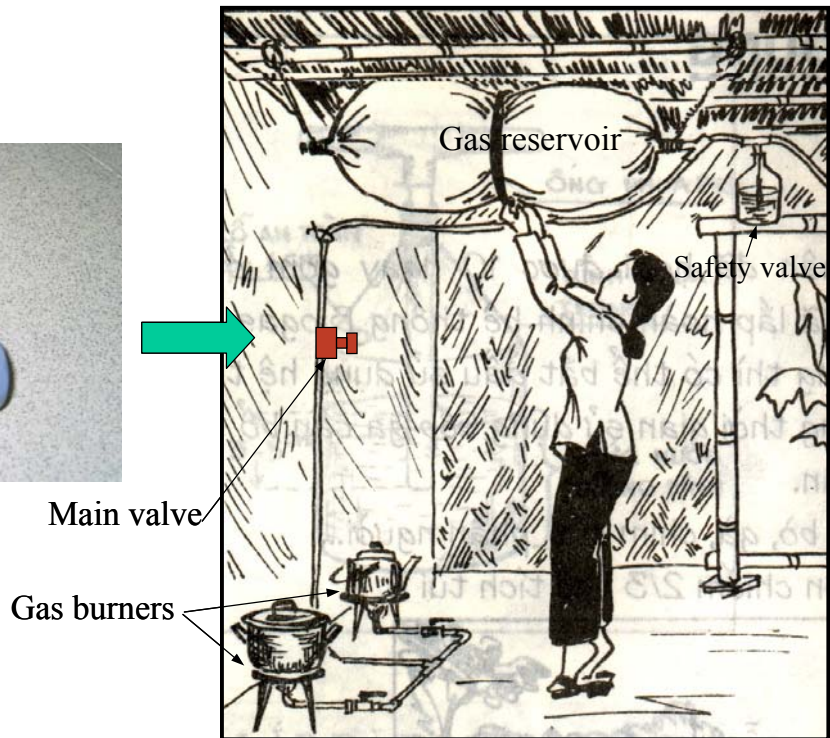
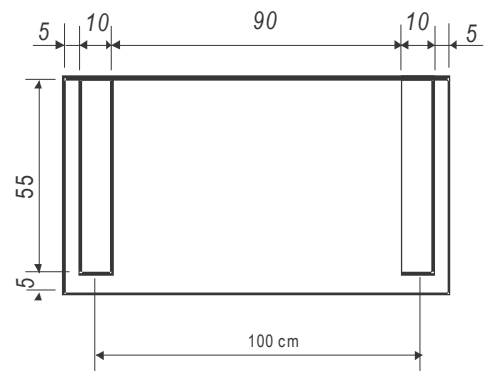

GENERAL SCHEME OF VACVINA BIODIGESTER

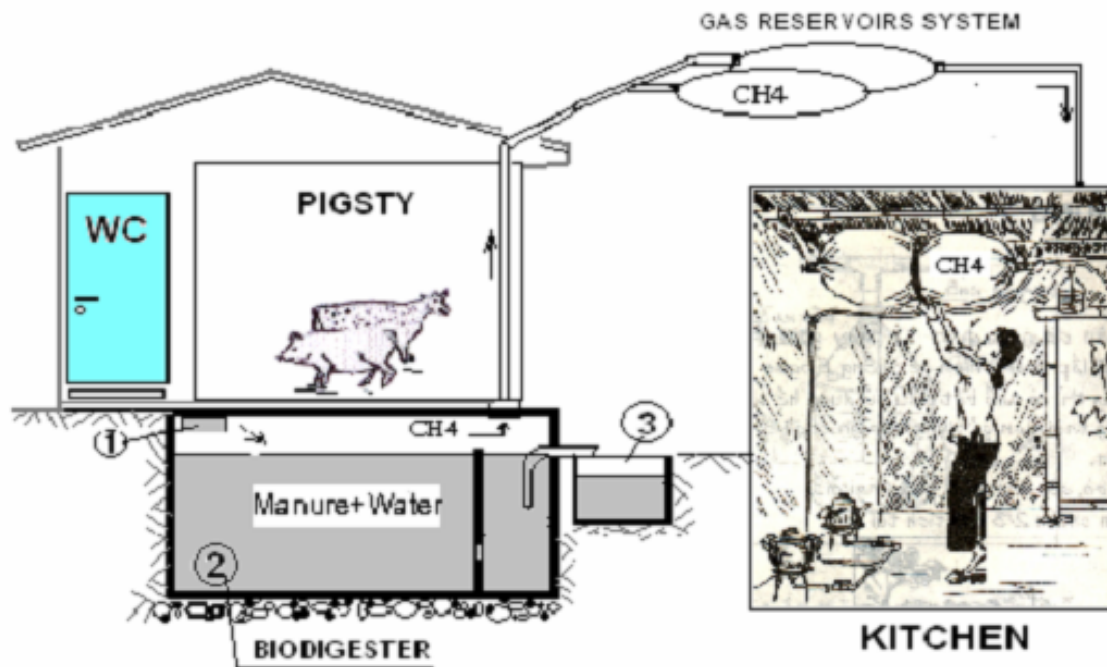

Outlet

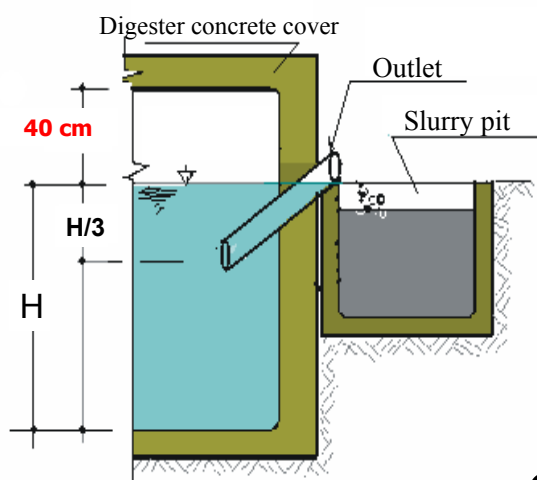

Safety valve

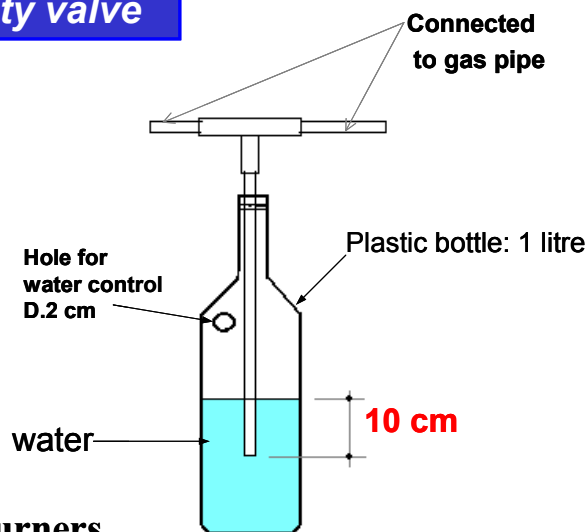

Gas Burners

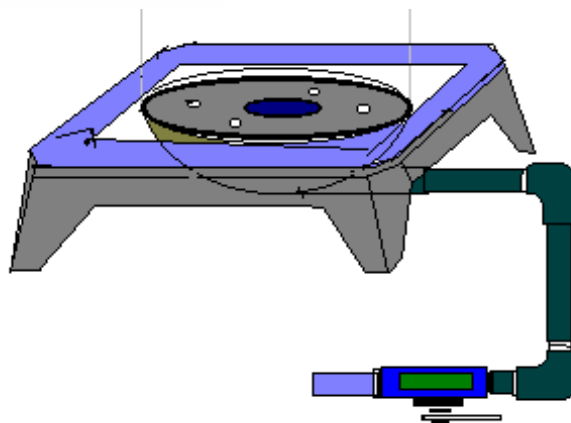

Appliances for entire biogas system

- 5. Valve functioned for cooking
- 6. Biogas burners

- 1. Siphon for inlets
- 2. Outlet
- 3. Gas-conducted tube
- 4. Metal pipe directly connected from digester



*** End ***