

AREVA HTR: A process heat source to power many industrial applications

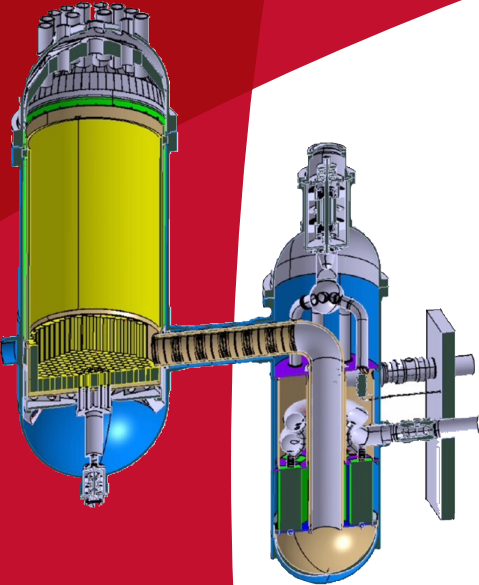

The most competitive vision for high-temperature process heat and hydrogen production in the future

One of AREVA's long-term strategic initiatives is the development of fourth-generation nuclear reactors. Through its subsidiary AREVA NP is investing in a number of Gen IV projects, including the company's ANTARES Development Program. The ANTARES program is charged with creating a commercially competitive, advanced high-temperature reactor (HTR) for electricity production, as well as a variety of industrial applications requiring a process heat supply.

The AREVA HTR is a high-temperature heat source that:

- Can co-produce 300MWe/max 600MWth of electricity and heat up to 800°C/1,472°F
- Incurs lower fuel costs as a fraction of the operating costs compared to fossil fuels.
- Uses safe, clean, affordable nuclear energy —
 - Uranium ore price changes have minimal impact on production costs
 - Long-term production price stability is shielded from volatile fossil fuel costs
 - No CO₂ or greenhouse gas releases subject to potential future emissions taxes
- Optimizes resources through high-efficiency heat and power cogeneration — up to 90% depending on applications

AREVA HTR concept can serve a variety of process heat markets

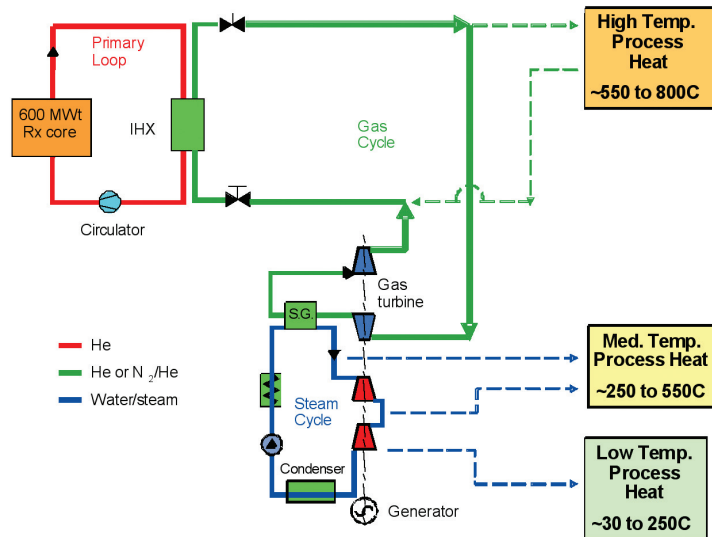

HTR TRISO Fuel

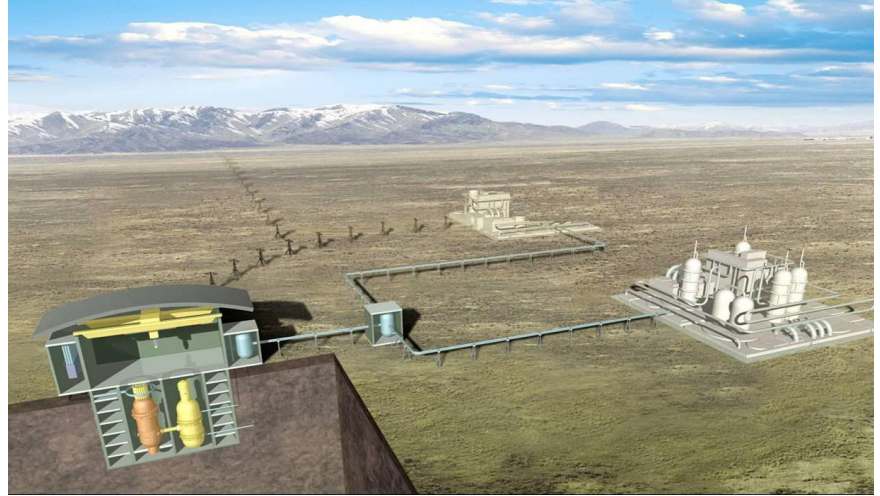
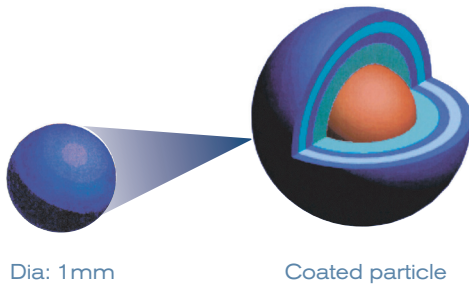

Courtesy of Idaho National Laboratory



BENEFITS

- No CO₂ emissions
- Efficient for producing both electricity and heat due to very high temperatures
- Diversification of energy sources increases energy independence and security
- More stable, predictable fuel costs than fossil fuels
- Adaptable to advanced fuel cycle, i.e., actinide burning

High Temperature Reactor Programs

AREVA NP, Inc.
3315 Old Forest Road
Lynchburg, VA 24501
Tel: 434-832-4271
Fax: 434-832-3828
US_HTRinfo@areva.com

AREVA NP, SAS
Tour AREVA
92084 Paris La Defense Cedex
France
Tel : +33 1 47 96 00 00
Fax : +33 1 47 96 36 36
FR_HTRinfo@areva.com

AREVA NP, GmbH
Freyeslebenstr. 1
D-91050 Erlangen
Germany
Tel: +49 9131 18 95374
Fax: +49 9131 18 94927
DE_HTRinfo@areva.com

www.us.areva.com

Applications for nuclear-generated process heat & electricity cogeneration

The indirect cycle design of the AREVA's HTR plant will be adaptable to industrial process heat supply and electricity generation, making it a versatile industrial nuclear heat source for a number of applications, including the following:

Petroleum Industry: Extraction and refineries

- Tar sands and heavy oil recovery — The AREVA HTR can provide the required high-pressure steam for field steam injection and the power for pumps used to extract the oil. It can also provide power for hydrogen production needed to upgrade the oil.
- Refining heavy oil with heat and hydrogen

Chemistry Industry

- Fertilizer
- Coupled Cl₂ and PVC chemistry

Coal Industry: Reducing CO₂ during the fabrication of synthetic fuels

- Synthetic gas production — Similar to coal liquefaction, coal gasification could bring independence from imports and decrease natural gas usage in various productions such as methanol and ammonia. Using nuclear heat to produce synthetic gas rather than fossil heat, virtually eliminates the production of CO₂ in that phase of the process.
- Coal liquefaction — Using the AREVA HTR to convert coal into synthetic oil optimizes such production while preserving the environment. In the U.S. with large coal deposits easily accessible, a substantial substitution for oil imports could be achieved.

Hydrogen production

In the short term, the AREVA HTR can be used as an external heat source for steam methane reforming, thus avoiding the use of natural gas as a fuel and reducing CO₂ emissions by one third. In the long term, the HTR will provide advanced hydrogen production from water splitting.

Other process heat applications include:

- Steel production
- Paper manufacturing
- Water desalination
- Any large use of both heat and power that would avoid the burning of gas or oil and the CO₂ emissions associated with that.

The data contained herein are solely for your information and are not to be construed as a warranty or other contractual obligation.

© 2006 AREVA NP, Inc. All rights reserved. 3/06
ANP:U-257-V1-06-ENG